

Y SERIES

Cylindrical Photoelectric Sensor

Amplifier Built-in

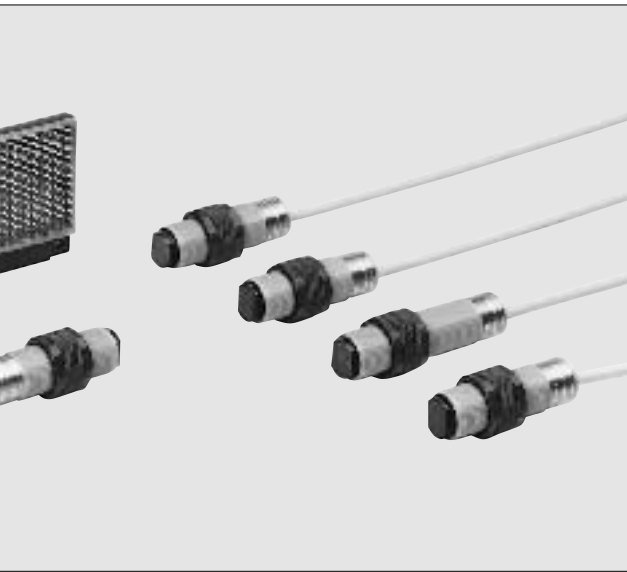

Cylindrical type easily mountable with M18 thread

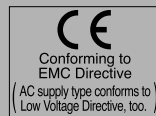

Easy to replace
The sensor has an M18 thread size for easy mounting.

Easy to replace
A pigtailed type sensor with connector (CY-□-J), which is easy to replace, is also available.

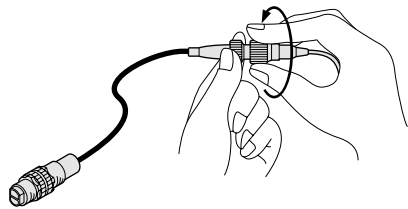
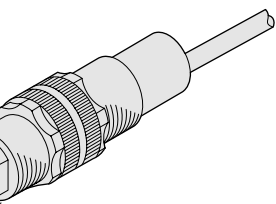

Long sensing range

Thru-beam type

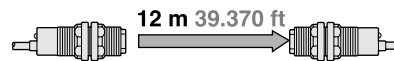

Retroreflective type

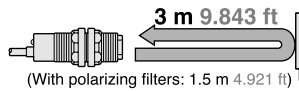

Diffuse reflective type

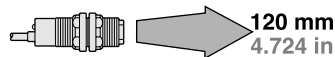

Sensing range
The sensor is available in AC type (24 to 240 V AC) and DC type (10 to 30 V DC).

Environment resistant
Its IP67 construction can be hosed down with water. In addition, it has strong resistance against vibration since it is filled up with resin. The connector also has IP67 protection.



Convenient options
Side-view attachment (For thru-beam type sensors only)
The beam is bent at a right angle with the side-view attachment.



Slit mask (For thru-beam type sensors only)
It is convenient for detecting small objects or enhancing the sensing accuracy.



PNP collector transistor
NPN collector transistor
Relay contact (thyristor) output
Various models are available.

APPLICATIONS

cardboard boxes

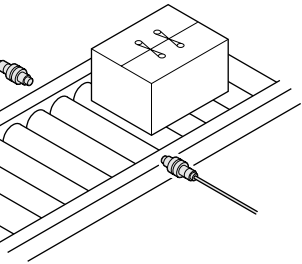



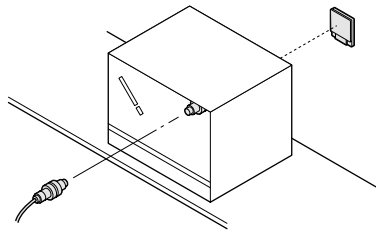



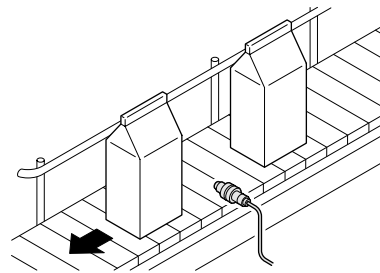



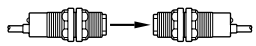

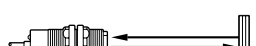

Sensing specular objects

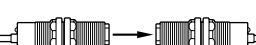

Sensing milk packs

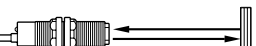

SELECTION GUIDE

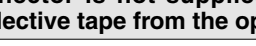
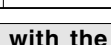
| | Appearance | Sensing range | Model No. | Supply voltage | Output | Output operation |
|--|--|--|-------------------------------|--------------------------|-----------------------------------|--|
| filters |  |  12 m 39.370 ft | CY-21 | 10 to 30 V DC | NPN open-collector transistor | Selectable either Light-ON or Dark-ON by the control input |
| | | | CY-21-PN | | PNP open-collector transistor | |
| |  |  3 m 9.843 ft (Note) | CY-27 | | NPN open-collector transistor | |
| | | | CY-27-PN | | PNP open-collector transistor | |
| |  |  1.5 m 4.921 ft (Note) | CY-29 | | NPN open-collector transistor | |
| | | | CY-29-PN | | PNP open-collector transistor | |
|  |  120 mm 4.724 in | CY-22 | NPN open-collector transistor | | | |
| | | CY-22-PN | PNP open-collector transistor | | | |
| filters |  |  12 m 39.370 ft | CY-11A | 24 to 240 V AC ± 10 % | AC non-contact (thyristor) output | Light-ON |
| | | | CY-11B | | | Dark-ON |
| |  |  3 m 9.843 ft (Note) | CY-17A | | | Light-ON |
| | | | CY-17B | | | Dark-ON |
| |  |  1.5 m 4.921 ft (Note) | CY-19A | | | Light-ON |
| | | | CY-19B | | | Dark-ON |
| |  |  120 mm 4.724 in | CY-12A | | | Light-ON |
| | | | CY-12B | | | Dark-ON |

Reflector is not supplied with the retroreflective type sensor. Please select the suitable reflector or reflective tape from the options.

Sensing range of the retroreflective type sensor is specified for the RF-230 reflector (optional).

GUIDE

pe
s also available.

del Nos.

| Model No. | Standard | Pigtailed type (Note) |
|-------------------------|-----------------|-----------------------|
| Through-beam | CY-21 | CY-21-J |
| Retroreflective | CY-27 | CY-27-J |
| With polarizing filters | CY-29 | CY-29-J |
| Diffuse reflective | CY-22 | CY-22-J |
| Through-beam | CY-21-PN | CY-21-PN-J |
| Retroreflective | CY-27-PN | CY-27-PN-J |
| With polarizing filters | CY-29-PN | CY-29-PN-J |
| Diffuse reflective | CY-22-PN | CY-22-PN-J |
| Through-beam | CY-11A | CY-11A-J |
| Retroreflective | CY-17A | CY-17A-J |
| With polarizing filters | CY-19A | CY-19A-J |
| Diffuse reflective | CY-12A | CY-12A-J |
| Through-beam | CY-11B | CY-11B-J |
| Retroreflective | CY-17B | CY-17B-J |
| With polarizing filters | CY-19B | CY-19B-J |
| Diffuse reflective | CY-12B | CY-12B-J |

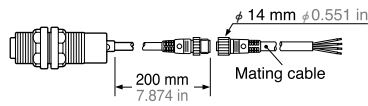

Order the suitable mating cable separately.

le

| Model No. | Description |
|-----------------|-----------------------|
| CN-22-C2 | Length: 2 m 6.562 ft |
| CN-22-C5 | Length: 5 m 16.404 ft |
| CN-24-C2 | Length: 2 m 6.562 ft |
| CN-24-C5 | Length: 5 m 16.404 ft |
| CN-32-C2 | Length: 2 m 6.562 ft |
| CN-32-C5 | Length: 5 m 16.404 ft |
| CN-33-C2 | Length: 2 m 6.562 ft |
| CN-33-C5 | Length: 5 m 16.404 ft |

AC supply type mating cable and the AC supply type mating cable have different connector
type and so are not interchangeable.

For the test input (emission halt input) use the 4-core **CN-24-C**.

| Attachment | Model No. | Description | | |
|-----------------------|------------------------|---|---|--|
| Beam (beam only) | OS-CYS | Slit size 11.6 × 0.5 mm 0.457 × 0.020 in | Slit on emitter • Sensing range: 3 m 9.843 ft • Min. sensing object: ϕ 8 mm ϕ 0.315 in | |
| | | Slit on receiver | • Sensing range: 2.5 m 8.202 ft • Min. sensing object: ϕ 8 mm ϕ 0.315 in | |
| | | | Slit on both sides | • Sensing range: 0.8 m 2.625 ft • Min. sensing object: 10 × 0.7 mm 0.394 × 0.028 in |
| | | | Slit size 11.6 × 1.5 mm 0.457 × 0.059 in | Slit on emitter |
| | | Slit on receiver | | • Sensing range: 4.5 m 14.764 ft • Min. sensing object: ϕ 8 mm ϕ 0.315 in |
| | | Slit on both sides | | • Sensing range: 2 m 6.562 ft • Min. sensing object: 10 × 2 mm 0.394 × 0.079 in |
| | | Slit size 11.6 × 3 mm 0.457 × 0.118 in | Slit on emitter | • Sensing range: 7.5 m 24.606 ft • Min. sensing object: ϕ 8 mm ϕ 0.315 in |
| | | | Slit on receiver | • Sensing range: 7 m 22.966 ft • Min. sensing object: ϕ 8 mm ϕ 0.315 in |
| | | | Slit on both sides | • Sensing range: 4.5 m 14.764 ft • Min. sensing object: 10 × 3 mm 0.394 × 0.118 in |
| | Attachment (beam only) | CY-SV1 | The beam is bent at a right angle by the attachments. • Sensing range (with attachment on both sides): 8 m 26.247 ft | |
| | Effective (only) | RF-230 | • Sensing range: 3 m 9.843 ft [CY-27□ & CY-17□], 1.5 m 4.921 ft [CY-29□ & CY-19□] | |
| | | RF-220 | • Sensing range: 2 m 6.562 ft [CY-27□ & CY-17□], 1.2 m 3.937 ft [CY-29□ & CY-19□] | |
| RF-210 | | • Sensing range: 1 m 3.281 ft [CY-27□ & CY-17□], 0.7 m 2.297 ft [CY-29□ & CY-19□] | | |
| Bracket | MS-RF21-1 | Protective mounting bracket for RF-210 It protects the reflector from damage and maintains alignment. | | |
| | MS-RF22 | For RF-220 | | |
| | MS-RF23 | For RF-230 | | |
| Tape (effective only) | RF-12 | • Sensing range: 0.7 m 2.297 ft [CY-27□ & CY-17□], 0.4 m 1.312 ft [CY-29□ & CY-19□] | | |
| | RF-11 | • Sensing range: 0.5 m 1.640 ft [CY-27□ & CY-17□] | | |
| Checker | CHX-SC2 | It is useful for beam alignment of thru-beam type sensors. The optimum receiver position is given by indicators, as well as an audio signal. | | |

to p.414~ for details on the sensor checker **CHX-SC2**.

Side-view attachment
• **CY-SV1**



Reflective tape
• **RF-12**

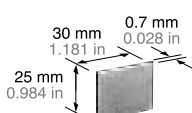

• **RF-11**

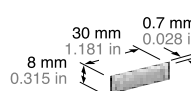

• **RF-220**

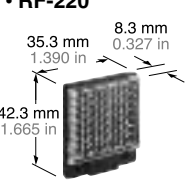

Reflector mounting bracket
• **MS-RF23**

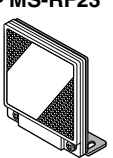

Two M4 (length 10 mm 0.394 in) screws with washers are attached.

• **MS-RF22**



Two M3 (length 8 mm 0.315 in) screws with washers are attached.

• **MS-RF21-1**



Two M3 (length 12 mm 0.472 in) screws with washers are attached.

Sensor checker
• **CHX-SC2**



APPLICATIONS

type

| Type | Thru-beam | Retroreflective | | Diffuse reflective |
|--------------------------|--|--|--|---|
| | | | With polarizing filters | |
| NPN output type | CY-21 | CY-27 | CY-29 | CY-22 |
| PNP output type | CY-21-PN | CY-27-PN | CY-29-PN | CY-22-PN |
| | 12 m 39.370 ft | 3 m 9.843 ft (Note 1) | 1.5 m 4.921 ft (Note 1) | 120 mm 4.724 in (Note 2) |
| | φ 8 mm φ 0.315 in or more opaque object | φ 50 mm φ 1.969 in or more opaque or translucent object (Note 1) | φ 50 mm φ 1.969 in or more opaque, translucent or specular object (Note 1) | Opaque, translucent or transparent object |
| | | | | 15 % or less of operation distance |
| to sensing axis) | 0.1 mm 0.004 in or less | | | 0.3 mm 0.012 in or less |
| | 10 to 30 V DC Ripple P-P 10 % or less | | | |
| emission | Emitter: 20 mA or less Receiver: 25 mA or less | 25 mA or less | | |
| category | <NPN output type> NPN open-collector transistor <ul style="list-style-type: none"> • Maximum sink current: 100 mA • Applied voltage: 30 V DC or less (between output and 0 V) • Residual voltage: 1.5 V or less (at 100 mA sink current) | | <PNP output type> PNP open-collector transistor <ul style="list-style-type: none"> • Maximum source current: 100 mA • Applied voltage: 30 V DC or less (between output and + V) • Residual voltage: 1.5 V or less (at 100 mA source current) | |
| operation | DC-12 or DC-13 | | | |
| operation | Selectable either Light-ON or Dark-ON by the control input | | | |
| output protection | Incorporated | | | |
| response | 2 ms or less | | | |
| operation halt) function | Incorporated | | | |
| indicator | Red LED (lights up when the output is ON) | | | |
| indicator | Red LED (lights up during beam emission) | | | |
| degree | 3 (Industrial environment) | | | |
| protection | IP67 (IEC) | | | |
| temperature | - 25 to + 55 °C - 13 to + 131 °F (No dew condensation or icing allowed), Storage: - 30 to + 70°C - 22 to + 158 °F | | | |
| humidity | 35 to 85 % RH, Storage: 35 to 85 % RH | | | |
| illumination | Sunlight: 10,000 lx at the light-receiving face, Incandescent light: 3,000 lx at the light-receiving face | | | |
| standards | EN 50081-2, EN 50082-2, EN 60947-5-2 | | | |
| withstandability | 1,000 V AC for one min. between all supply terminals connected together and enclosure | | | |
| resistance | 20 MΩ, or more, with 250 V DC megger between all supply terminals connected together and enclosure | | | |
| resistance | 10 to 500 Hz frequency, 1.5 mm 0.059 in amplitude (10 G max.) in X, Y and Z directions for two hours each | | | |
| resistance | 500 m/s ² acceleration (50 G approx.) in X, Y and Z directions for three times each | | | |
| output | Infrared LED (modulated) | Red LED (modulated) | Infrared LED (modulated) | |
| | Enclosure: PBT, Lens: Polycarbonate | Enclosure: PBT, Front cover: Acrylic | | |
| | 0.34 mm ² 4-core (thru-beam type emitter: 3-core) cable, 2 m 6.562 ft long | | | |
| extension | Extension up to total 100 m 328.084 ft is possible with 0.34 mm ² , or more, cable (thru-beam type: both emitter and receiver). | | | |
| | Emitter: 90 g approx. Receiver: 100 g approx. | 100 g approx. | | |
| | Nut: 4 pcs. | Nut: 2 pcs. | | |

Reflector is not supplied with the retroreflective type sensor. Please select the suitable reflector or reflective tape from the options.

Sensing range and the sensing object of the retroreflective type sensor are specified for the **RF-230** reflector (optional).
Sensing range of the diffuse reflective type sensor is specified for white non-glossy paper (200 × 200 mm 7.874 × 7.874 in) as the object.

IFICATIONS

ly type

| Type | | Thru-beam | Retroreflective | | Diffuse reflective |
|---|----------|---|--|--|---|
| | | | With polarizing filters | | |
| Model No. | Light-ON | CY-11A | CY-17A | CY-19A | CY-12A |
| | Dark-ON | CY-11B | CY-17B | CY-19B | CY-12B |
| Sensing range | | 12 m 39.370 ft | 3 m 9.843 ft (Note 1) | 1.5 m 4.921 ft (Note 1) | 120 mm 4.724 in (Note 2) |
| Sensing object | | φ8 mm φ0.315 in or more opaque object | φ50 mm φ1.969 in or more opaque or translucent object (Note 1) | φ50 mm φ1.969 in or more opaque, translucent or specular object (Note 1) | Opaque, translucent or transparent object |
| Sensing distance | | | | | 15 % or less of operation distance |
| Sensing accuracy (parallel to sensing axis) | | 0.1 mm 0.004 in or less | | | 0.3 mm 0.012 in or less |
| Supply voltage | | 24 to 240 V AC ± 10 % | | | |
| Power consumption | | Emitter: 1.5 VA or less Receiver: 2.5 VA or less | 2.7 VA or less | | |
| Output | | AC non-contact (thyristor) output • Load current: 5 to 200 mA • Applied voltage: 24 to 240 V AC ± 10 % • Residual voltage: 4 V AC or less (at 200 mA load current) | | | |
| Response time | | 20 ms or less | | | |
| Indicator | | Red LED (lights up when the output is ON), incorporated on the receiver for the thru-beam type sensor | | | |
| Indicator color | | Red LED (lights up when the power is ON), incorporated on the emitter | | | |
| Protection degree | | 3 (Industrial environment) | | | |
| Ingress protection | | IP67 (IEC) | | | |
| Operating temperature | | - 25 to + 55 °C - 13 to + 131 °F (No dew condensation or icing allowed), Storage: - 30 to + 70 °C - 22 to + 158 °F | | | |
| Operating humidity | | 35 to 85 % RH, Storage: 35 to 85 % RH | | | |
| Operating illuminance | | Sunlight: 10,000 lx at the light-receiving face, Incandescent light: 3,000 lx at the light-receiving face | | | |
| Compliance | | EN 50081-2, EN 50082-2, EN 60947-5-2 | | | |
| Voltage withstandability | | 1,500 V AC for one min. between all supply terminals connected together and enclosure | | | |
| Insulation resistance | | 20 MΩ, or more, with 500 V DC megger between all supply terminals connected together and enclosure | | | |
| Vibration resistance | | 10 to 500 Hz frequency, 1.5 mm 0.059 in amplitude (10 G max.) in X, Y and Z directions for two hours each | | | |
| Shock resistance | | 500 m/s ² acceleration (50 G approx.) in X, Y and Z directions for three times each | | | |
| Emission | | Infrared LED (modulated) | Red LED (modulated) | Infrared LED (modulated) | |
| Enclosure | | Enclosure: PBT, Lens: Polycarbonate | | Enclosure: PBT, Front cover: Acrylic | |
| Cable | | 0.34 mm ² 3-core (thru-beam type emitter: 2-core) cable, 2 m 6.562 ft long | | | |
| Extension | | Extension up to total 100 m 328.084 ft is possible with 0.34 mm ² , or more, cable (thru-beam type: both emitter and receiver). | | | |
| Weight | | Emitter: 90 g approx. Receiver: 100 g approx. | 100 g approx. | | |
| Screws | | Nut: 4 pcs. | | Nut: 2 pcs. | |

Reflector is not supplied with the retroreflective type sensor. Please select the suitable reflector or reflective tape from the options.

The sensing range and the sensing object of the retroreflective type sensor are specified for the **RF-230** reflector (optional).

The sensing range of the diffuse reflective type sensor is specified for white non-glossy paper (200 × 200 mm 7.874 × 7.874 in) as the object.

WIRING AND WIRING DIAGRAMS

Output type

Wiring diagram

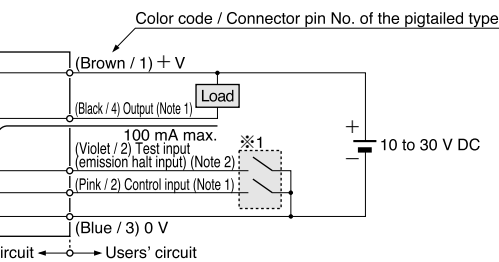

The emitter of the thru-beam type sensor does not incorporate the output and the control input.

When the mating cable is connected to the pigtailed type, the color of the control input wire is

white. The test input (emission halt input) is incorporated on the emitter of the thru-beam type sensor. When the mating cable is connected to the pigtailed type, its color is white.

- Zp: Reverse supply polarity protection diode
- Z: Surge absorption zener diode
- : NPN output transistor

Wiring diagram

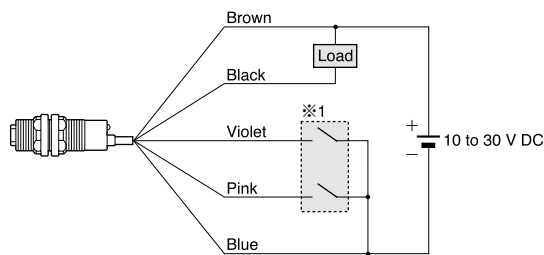

Connector pin position (Pigtailed type)

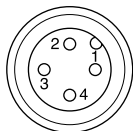

- 1: + V
- 2: Test input (emission halt input) or control input
- 3: 0 V
- 4: Output or not connected

※1

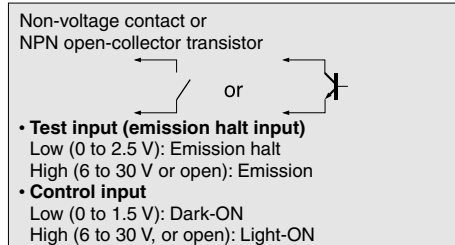

Note: If opening the input cable, make sure to insulate it.

Output type

Wiring diagram

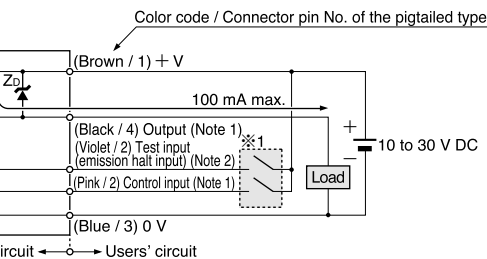

The emitter of the thru-beam type sensor does not incorporate the output and the control input.

When the mating cable is connected to the pigtailed type, the color of the control input wire is

white. The test input (emission halt input) is incorporated on the emitter of the thru-beam type sensor. When the mating cable is connected to the pigtailed type, its color is white.

- Zp: Reverse supply polarity protection diode
- Z: Surge absorption zener diode
- : PNP output transistor

Wiring diagram

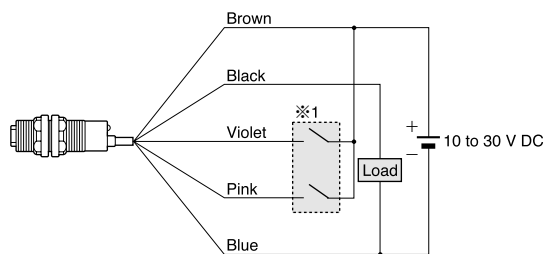

Connector pin position (Pigtailed type)

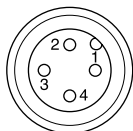

- 1: + V
- 2: Test input (emission halt input) or control input
- 3: 0 V
- 4: Output or not connected

※1

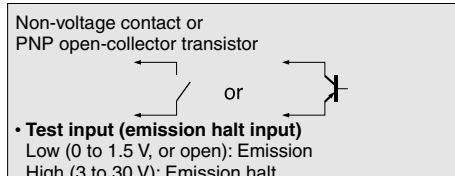

WIRING DIAGRAMS

Thru-beam type

Wiring diagrams

Emitter of thru-beam type sensor

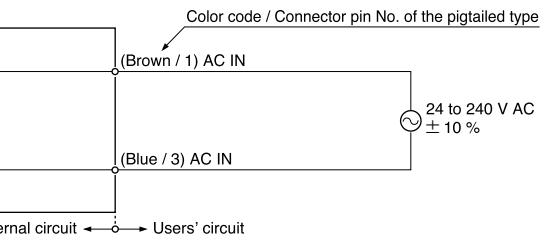

Wiring diagrams

Emitter of thru-beam type sensor

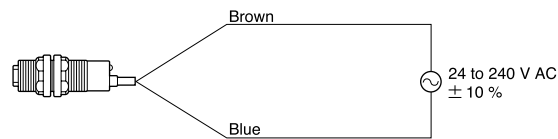

Receiver of thru-beam type sensor, retroreflective & diffuse reflective type sensors

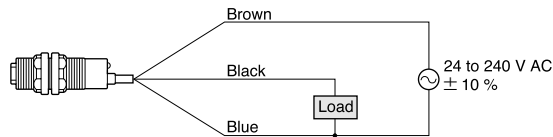

Receiver of thru-beam type sensor, retroreflective & diffuse reflective type sensors

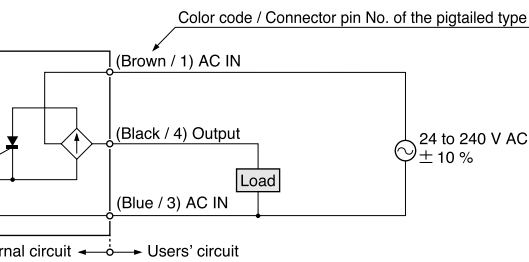

Connector pin position (Pigtailed type)

Emitter of thru-beam type sensor

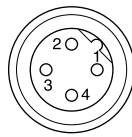

- 1: AC IN
- 2: Not connected
- 3: AC IN
- 4: Not connected

Receiver of thru-beam type sensor, retroreflective & diffuse reflective type sensors

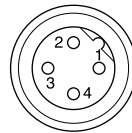

- 1: AC IN
- 2: Not connected
- 3: AC IN
- 4: Output

PERFORMANCE CHARACTERISTICS (TYPICAL)

Models

Relationship between setting distance and excess gain

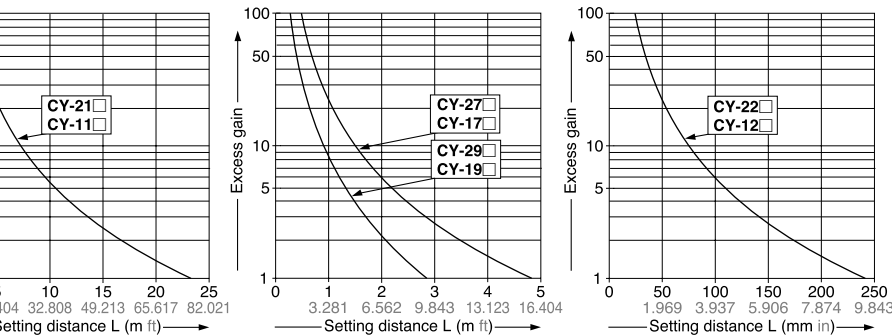

CY-21 / CY-11 Thru-beam type

Parallel deviation

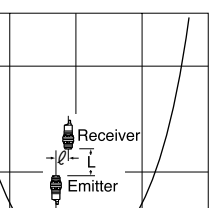

Angular deviation

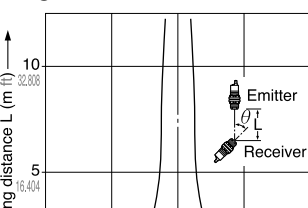

CY-27 / CY-17 Retroreflective type

Parallel deviation

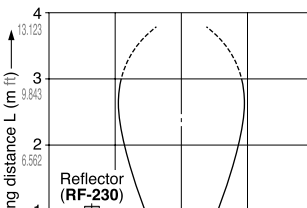

Angular deviation

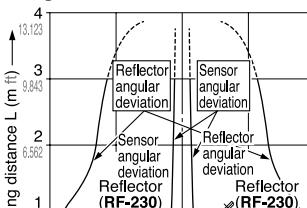

CHARACTERISTICS (TYPICAL)

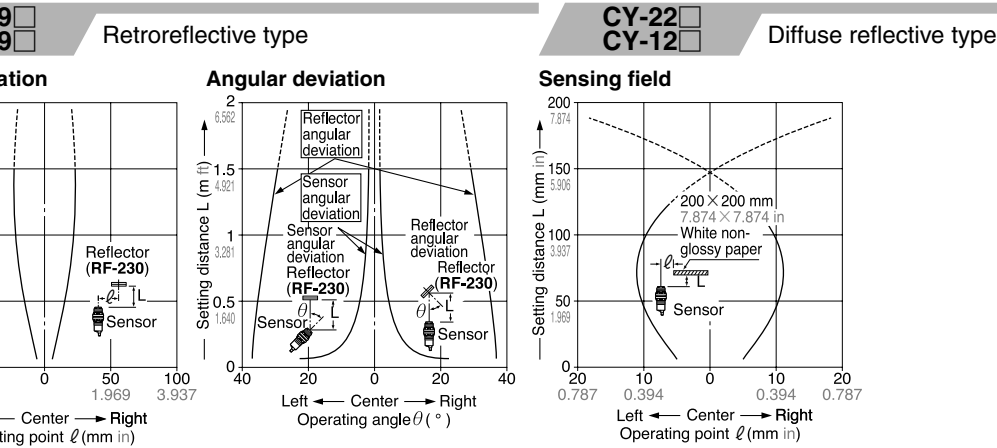

CONDITIONS FOR PROPER USE

This product is not a safety sensor. Its use is not intended or designed to protect life and prevent body injury or property damage from dangerous parts of machinery. It is a normal object detection sensor.

Mounting torque should be 2 N·m or less.

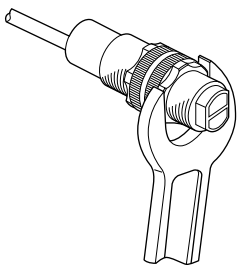

Retroreflective type sensor (CY-27□ and CY-17□)

• Please take care of the following points when detecting materials having a gloss.

- ① Make L, shown in the diagram, sufficiently long.
- ② Install at an angle of 10 to 30 degrees to the sensing object.

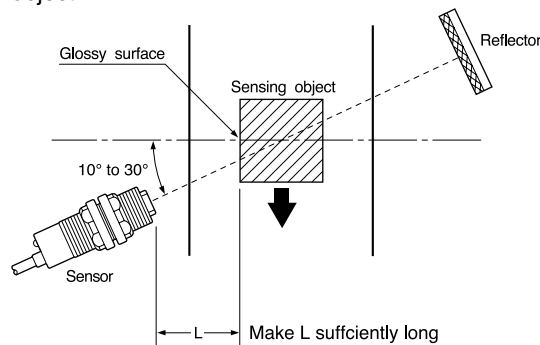

※CY-29□ and CY-19□ do not need the above adjustment.

Diffuse reflective type sensor with polarizing filters (CY-28□ and CY-19□)

If the sensing object is covered or wrapped with a transparent film as those described below, the retroreflective sensor with polarizing filters may not be able to detect the object.

In such cases, follow the steps given below.

Sensing objects

- Covered by clear film
- Covered by plastic film
- Covered by silver color (specular) label or wrapping paper

Adjust the sensor with respect to the sensing object while fitting. Measure the distance between the sensor and the sensing object.

Others

- Do not use during the initial transient time (50 ms) after the power supply is switched on.

Dimensions (Unit: mm in)

CY-27 Sensor

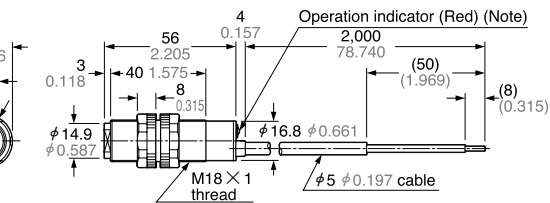

Note: It is the emitting indicator (red) on the emitter of the thru-beam type sensor.

CY-21-J **CY-27-J** **CY-22-J** Sensor

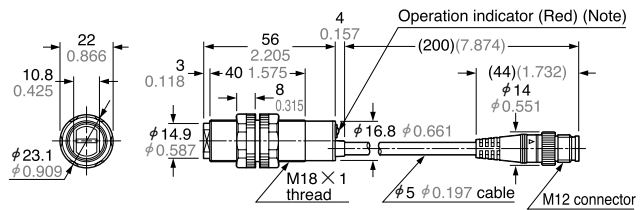

Note: It is the emitting indicator (red) on the emitter of the thru-beam type sensor.

CY-29 Sensor

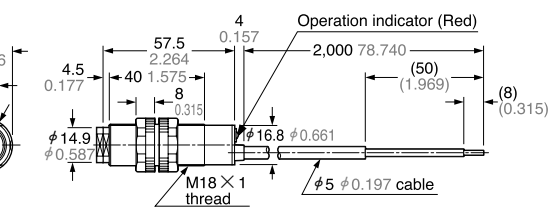

CY-29-J Sensor

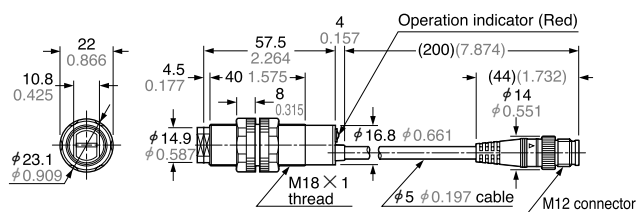

CY-17 Sensor

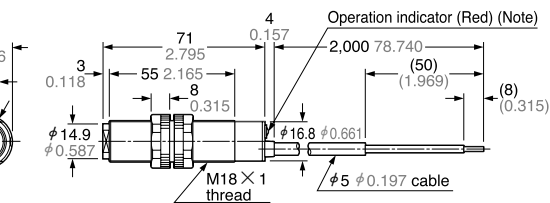

Note: It is the power indicator (red) on the emitter of the thru-beam type sensor.

CY-11-J **CY-17-J** **CY-12-J** Sensor

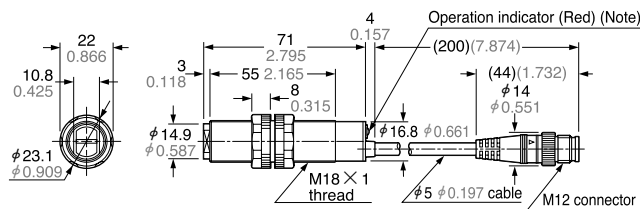

Note: It is the power indicator (red) on the emitter of the thru-beam type sensor.

CY-19 Sensor

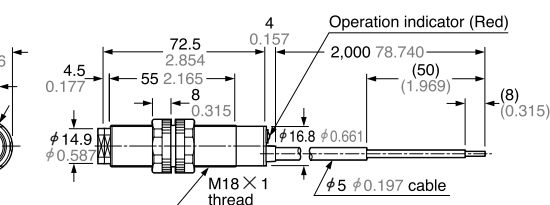

CY-19-J Sensor

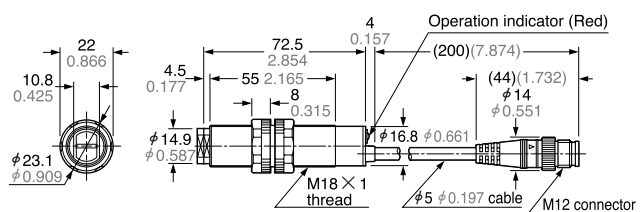

RF-210 Reflector (Optional)

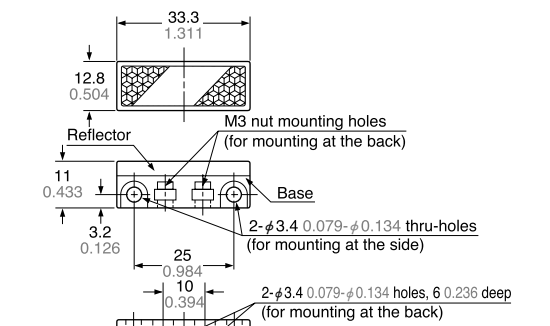

RF-220 Reflector (Optional)

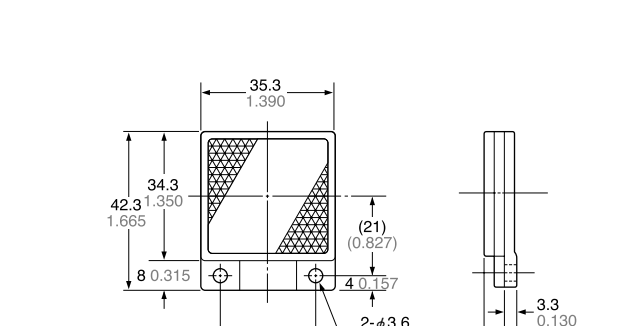

ENSIONS (Unit: mm in)

RF-30 Reflector (Optional)

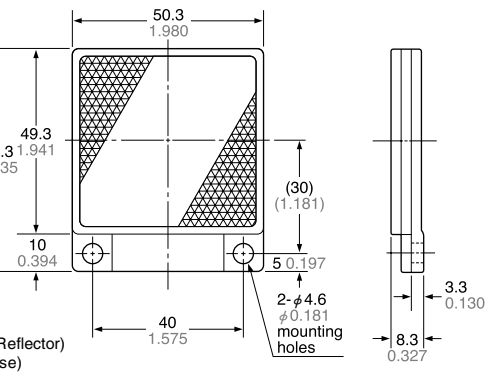

RF-11 Reflective tape (Optional)

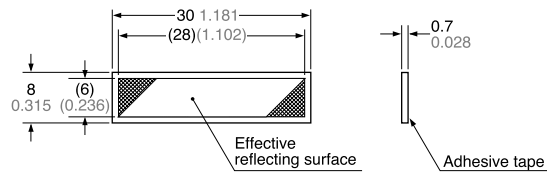

Material: Acrylic

RF-12 Reflective tape (Optional)

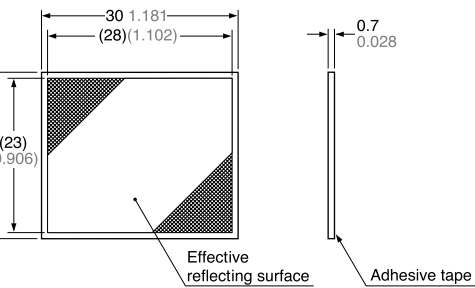

RF-21-1 Reflector mounting bracket for RF-210 (Optional)

Assembly dimensions

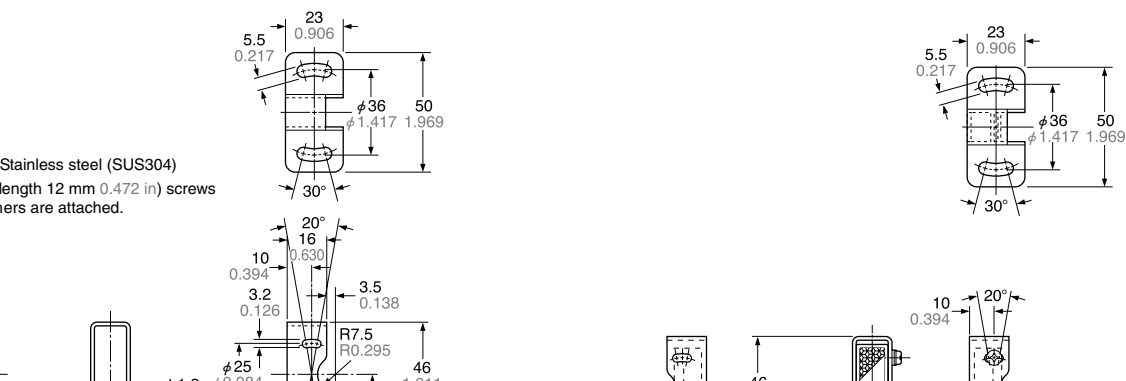

Dimensions (Unit: mm in)

-RF22 Reflector mounting bracket for RF-220 (Optional)

Assembly dimensions

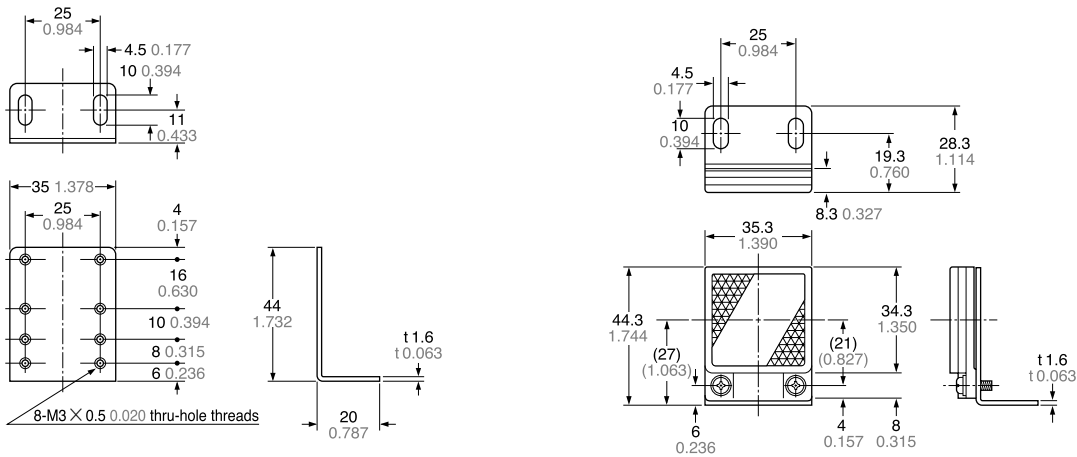

Material: Cold rolled carbon steel (SPCC)
(Uni-chrome plated)

Two M3 (length 8 mm 0.315 in) screws with washers are attached.

-RF23 Reflector mounting bracket for RF-230 (Optional)

Assembly dimensions

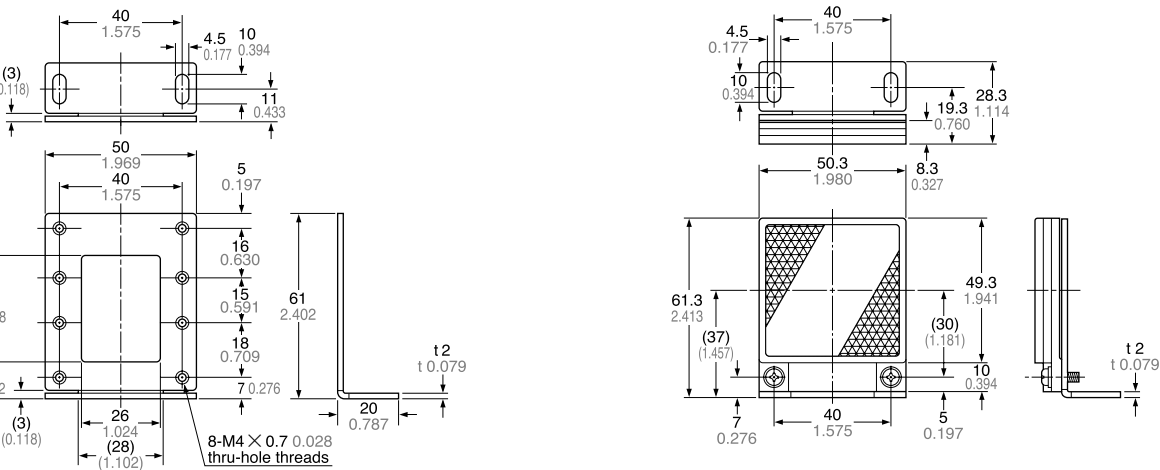

Material: Cold rolled carbon steel (SPCC)
(Uni-chrome plated)

Two M4 (length 10 mm 0.394 in) screws with washers are attached.

X-ON Electronics

Largest Supplier of Electrical and Electronic Components

Click to view similar products for [panasonic](#) manufacturer:

Other Similar products are found below :

[ECE-A1HKAR47](#) [ELC-09D151F](#) [HC2-H-DC48V-F](#) [HL2-HP-AC120V-F](#) [HL2-H-DC12V-F](#) [HL2-HP-DC12V-F](#) [HL2-HP-DC6V-F](#) [HL2-HP-DC24V-F](#) [HL2-H-DC110V-F](#) [HC4-H-DC24V](#) [HL2-HTM-DC24V-F](#) [HL2-HTM-AC24V-F](#) [HC4-H-AC24V](#) [HC4-H-AC120V](#) [HC4-H-DC12V](#) [AZH2031](#) [RP-SDMF64DA1](#) [EVM-F6SA00B55](#) [RP-SMLE08DA1](#) [ERZ-V20R391](#) [ELL-ATV681M](#) [ERZ-V05V680CB](#) [LT4H-DC24V](#) [LT4HL8-AC24V](#) [LT4HW-AC24V](#) [LT4HWT8-AC240V](#) [LT4HWT-AC240VS](#) [CY-122A-P](#) [ETQ-P5M470YFM](#) [EVAL_PAN1555](#) [EVQ-PAE04M](#) [EX-14B](#) [EX-22B-PN](#) [EX-31A-C5](#) [EXB-24N121JX](#) [MC-NA40-4](#) [EX-F72-PN](#) [EX-L211](#) [EYG-A121803V](#) [MFMCA0030AEB](#) [FCR-M50-AC208V](#) [FC-SFBH-20](#) [FC-SFBH-24](#) [FD-F8Y](#) [MHMA102A1C](#) [MHMD022S1S](#) [MHMD041S1S](#) [MHMD042G1T](#) [MHMD082G1T](#) [FD-S9](#)