

Micro Chip Fuse

Type: **ERB RD**
ERB RE
ERB RG



Features

- Small size
- Fast-acting and withstanding in-rush current characteristics
- RoHS compliant

Approved Safety Standards

UL248-14 : File No.E194052
c-UL C22.2 No.248-14 : File No.E194052

Explanation of Part Numbers

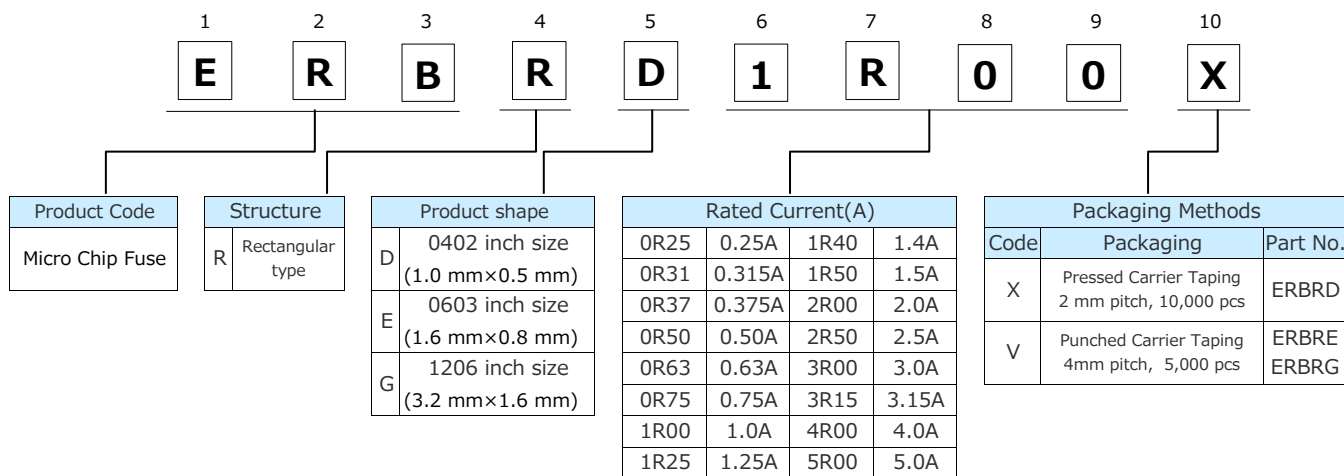

Construction

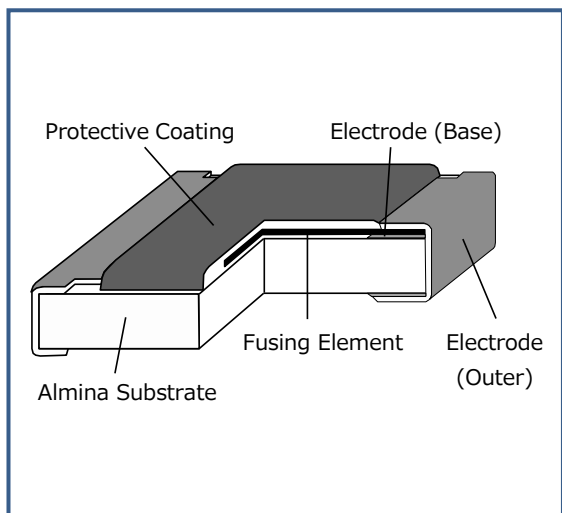

Dimensions in mm (not to scale)

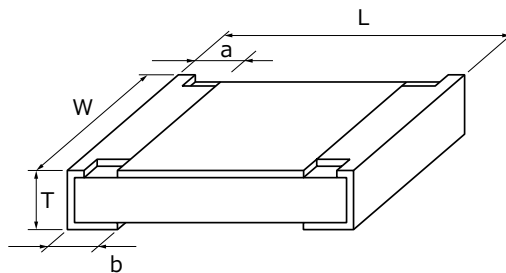

Part No. (inch size)	Dimensions(mm)					Mass (Weight) (g/1000 pcs)
	L	W	a	b	T	
ERBRD (0402)	1.00±0.10	0.50 ^{+0.10} _{-0.05}	0.15±0.10	0.25±0.10	0.39±0.10	0.7
ERBRE (0603)	1.60±0.15	0.80 ^{+0.15} _{-0.05}	0.24±0.15	0.30±0.15	0.54±0.10	2.2
ERBRG (1206)	3.20±0.20	1.60±0.15	0.30±0.20	0.55±0.20	0.65±0.10	10

Ratings

●0402 inch /1005 mm size : Type ERBRD

Part No.	ERBRD□R□□X													
	0R25	0R31	0R37	0R50	0R63	0R75	1R00	1R25	1R50	2R00	2R50	3R00	4R00	5R00
Rated Current(A)	0.25	0.315	0.375	0.5	0.63	0.75	1.0	1.25	1.5	2.0	2.5	3.0	4.0	5.0
Marking Code	V	X	Y	F	6	G	H	J	K	N	O	P	S	T
Internal R(mΩ) at 25 °C max.	700	520	440	310	220	190	125	82	70	53	42	37	24	19.5
Fusing Current/ Fusing Time (at 25 °C)	Rated Current ×100 % /4 hours min.													
	Rated Current ×200 % / 5 seconds max.													
	Rated Current ×300 % /0.2 seconds max.													
Rated Voltage (Open Circuit Voltage) (V)DC	32													
Interrupting Rating at Rated Voltage(A)	35													
Category Temp. Range(°C)	-40 to +125													

●0603 inch / 1608 mm size : Type ERBRE

Part No.	ERBRE□R□□V											
	0R50	0R75	1R00	1R25	1R40	1R50	2R00	2R50	3R00	3R15	4R00	5R00
Rated Current(A)	0.5	0.75	1.0	1.25	1.4	1.5	2.0	2.5	3.0	3.15	4.0	5.0
Marking Code	F	G	H	J	14	K	N	O	P	31	S	T
Internal R(mΩ) at 25 °C max.	330	190	125	94	85	72	51	40	33	32	22	19
Fusing Current/ Fusing Time (at 25 °C)	Rated Current ×100 % /4 hours min.											
	Rated Current ×200 % / 5 seconds max.											
	Rated Current ×300 % /0.2 seconds max.											
Rated Voltage (Open Circuit Voltage) (V)DC	32											
Interrupting Rating at Rated Voltage(A)	50											
Category Temp. Range(°C)	-40 to +125											

●1206 inch / 3216 mm size : Type ERBRG

Part No.	ERBRG□R□□V									
	0R50	0R75	1R00	1R25	1R50	2R00	2R50	3R00	4R00	
Rated Current(A)	0.5	0.75	1.0	1.25	1.5	2.0	2.5	3.0	4.0	
Marking Code	F	G	H	J	K	N	O	P	S	
Internal R(mΩ) at 25 °C max.	560	340	210	175	115	85	65	45	35	
Fusing Current/ Fusing Time (at 25 °C)	Rated Current ×100 % /4 hours min.									
	Rated Current ×200 % / 5 seconds max.									
	Rated Current ×300 % /0.2 seconds max.									
Rated Voltage (Open Circuit Voltage) (V)DC	63					32				
Interrupting Rating at Rated Voltage(A)	50									
Category Temp. Range(°C)	-40 to +125									

*The thin type is available about 1005 (0402 inch) size. Please contact us for details.

*Please contact us when another rated current is needed.

Fusing Characteristics (25 °C typical)

● 0402 inch / 1005 mm size

(Type ERBRD)

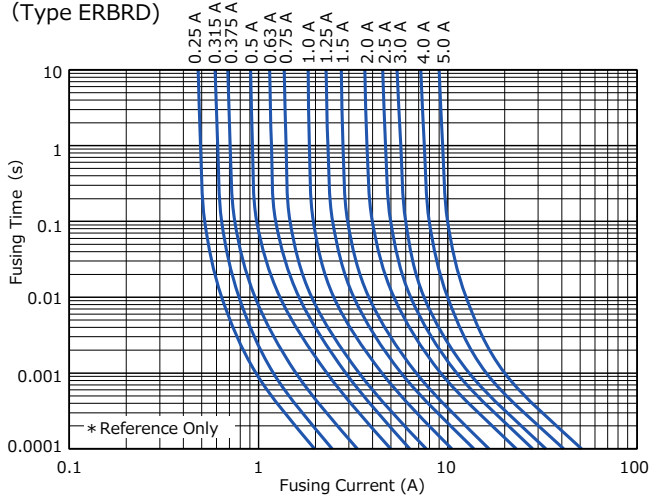

● 0603 inch / 1608 mm size

(Type ERBRE)

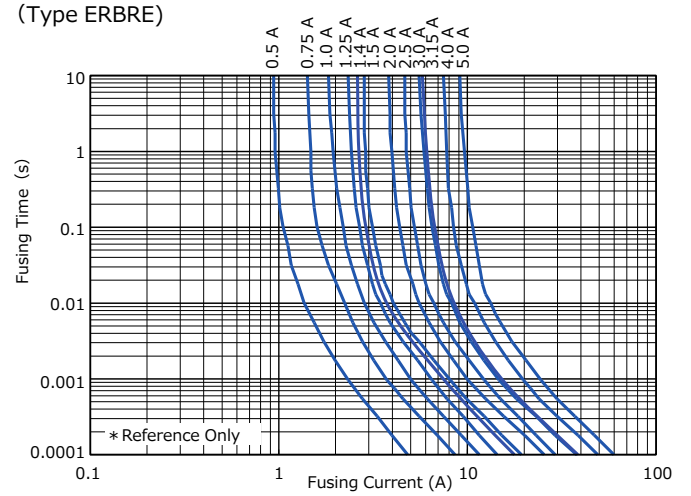

● 1206 inch / 3216mm size

(Type ERBRG)

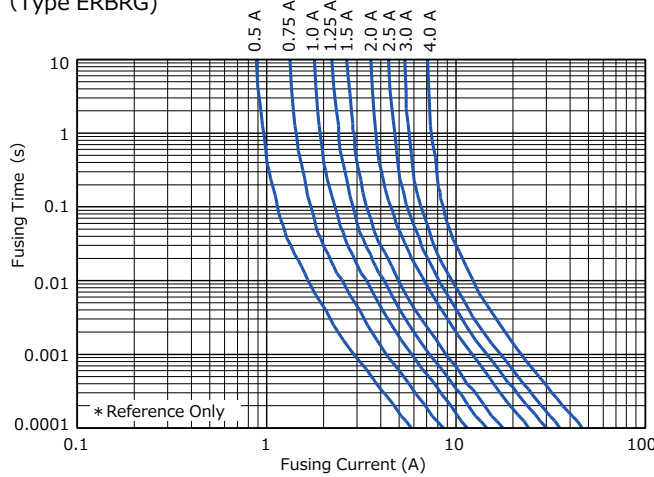

Performance

Test Item	Performance Requirements	Test Conditions
Resistance	Within Specified Tolerance	25 °C
Resistance to Soldering Heat	±10 %	260 °C±5 °C, 10 s
Rapid Change of Temperature	±10 %	-40 °C (30 min.) / + 125 °C (30 min.), 5 cycles
Damp Heat, Steady State	±10 %	60 °C, 90 % to 95 %RH, 1000 h (no load)
Load Life in Humidity	±10 %	60 °C, 90 % to 95 %RH, Load: 70 % rated current, 1000 h
Endurance at 70 °C	±10 %	70 °C, Load: 70 % rated current, 1000 h

Recommended Soldering Conditions

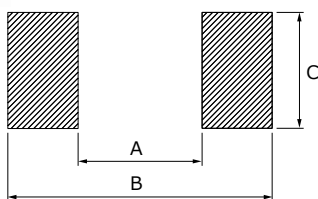

Part No. (inch size)	Dimensions(mm)		
	A	B	C
ERBRD (0402)	0.5 to 0.6	1.4 to 1.6	0.4 to 0.6
ERBRE (0603)	0.7 to 0.9	2.0 to 2.2	0.8 to 1.0
ERBRG (1206)	2.0 to 2.4	4.4 to 5.0	1.2 to 1.8

Packaging Methods (Taping)

● Standard Quantity

Part No.	Size (inch)	Kind of Taping	Pitch (P ₁)	Quantity
ERBRD	0402	Pressed Carrier Taping	2 mm	10,000 pcs / reel
ERBRE	0603	Punched Carrier Taping	4 mm	5,000 pcs / reel
ERBRG	1206			

● Carrier Taping (Unit : mm)

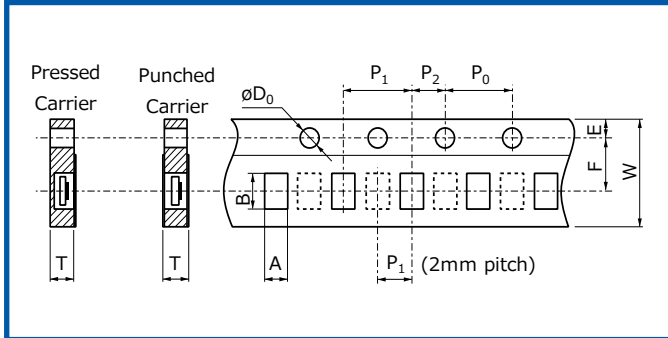

Part No.	A	B	W	F	E
ERBRD	0.68 ±0.10	1.20 ±0.10	8.00 ±0.20	3.50 ±0.05	1.75 ±0.10
ERBRE	1.10 ±0.10	1.90 ±0.10			
ERBRG	2.00 ±0.15	3.60 ±0.20			

Part No.	P ₁	P ₂	P ₀	ϕD_0	T
ERBRD	2.00 ±0.10	2.00 ±0.05	4.00 ±0.10	1.50 ^{+0.10} ₀	0.67 ±0.07
ERBRE	4.00 ±0.10				0.78 ±0.07
ERBRG					0.84 ±0.07

● Taping Reel (Unit : mm)

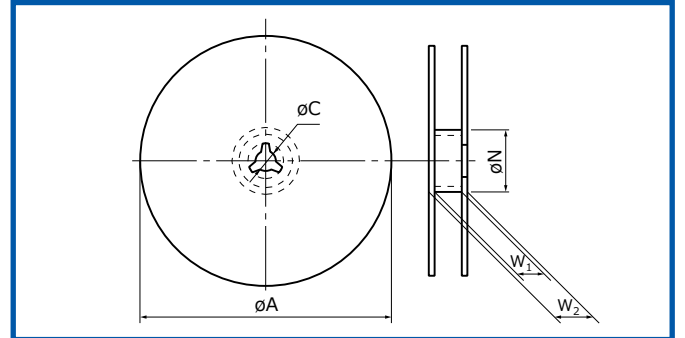

Part No.	ϕA	ϕN	ϕC	W ₁	W ₂
ERBRD ERBRE ERBRG	180.0 ⁰ _{-1.5}	60 ^{+1.0} ₀	13.0 ±0.2	9.0 ^{+1.0} ₀	11.4 ±1.0

Recommended Soldering Conditions

Recommendations and precautions are described below

● Recommended soldering conditions for reflow

- Reflow soldering shall be performed a maximum of two times.
- Please contact us for additional information when used in conditions other than those specified.
- Please measure the temperature of the terminals and study every kind of solder and printed circuit board for solderability before actual use.

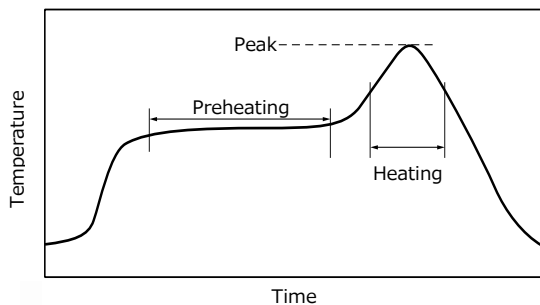

For soldering (Example : Sn/Pb)

	Temperature	Time
Preheating	140 °C to 160 °C	60 s to 120 s
Main heating	Above 200 °C	30 s to 40 s
Peak	235 ± 5 °C	max. 10 s

For lead-free soldering (Example : Sn/Ag/Cu)

	Temperature	Time
Preheating	150 °C to 180 °C	60 s to 120 s
Main heating	Above 230 °C	30 s to 40 s
Peak	max. 260 °C	max. 10 s

● Recommended soldering conditions for flow

	For soldering		For lead-free soldering	
	Temperature	Time	Temperature	Time
Preheating	140 °C to 160 °C	60 s to 120 s	150 °C to 180 °C	60 s to 120 s
Soldering	245±5 °C	20 s to 30 s	max. 260 °C	max. 10 s

«Repair with hand soldering»

- Preheat with a blast of hot air or similar method. Use a soldering iron with a tip temperature of 350 °C or less. Solder each electrode for 3 seconds or less.
- Never touch this product with the tip of a soldering iron.

Guidelines and precautions regarding the technical information and use of our products described in this online catalog.

- If you want to use our products described in this online catalog for applications requiring special qualities or reliability, or for applications where the failure or malfunction of the products may directly jeopardize human life or potentially cause personal injury (e.g. aircraft and aerospace equipment, traffic and transportation equipment, combustion equipment, medical equipment, accident prevention, anti-crime equipment, and/or safety equipment), it is necessary to verify whether the specifications of our products fit to such applications. Please ensure that you will ask and check with our inquiry desk as to whether the specifications of our products fit to such applications use before you use our products.
- The quality and performance of our products as described in this online catalog only apply to our products when used in isolation. Therefore, please ensure you evaluate and verify our products under the specific circumstances in which our products are assembled in your own products and in which our products will actually be used.
- If you use our products in equipment that requires a high degree of reliability, regardless of the application, it is recommended that you set up protection circuits and redundancy circuits in order to ensure safety of your equipment.
- The products and product specifications described in this online catalog are subject to change for improvement without prior notice. Therefore, please be sure to request and confirm the latest product specifications which explain the specifications of our products in detail, before you finalize the design of your applications, purchase, or use our products.
- The technical information in this online catalog provides examples of our products' typical operations and application circuits. We do not guarantee the non-infringement of third party's intellectual property rights and we do not grant any license, right, or interest in our intellectual property.
- If any of our products, product specifications and/or technical information in this online catalog is to be exported or provided to non-residents, the laws and regulations of the exporting country, especially with regard to security and export control, shall be observed.

<Regarding the Certificate of Compliance with the EU RoHS Directive/REACH Regulations>

- The switchover date for compliance with the RoHS Directive/REACH Regulations varies depending on the part number or series of our products.
- When you use the inventory of our products for which it is unclear whether those products are compliant with the RoHS Directive/REACH Regulation, please select "Sales Inquiry" in the website inquiry form and contact us.

We do not take any responsibility for the use of our products outside the scope of the specifications, descriptions, guidelines and precautions described in this online catalog.

Safety Precautions (Common precautions for Fuses)

- When using our products, no matter what sort of equipment they might be used for, be sure to make a written agreement on the specifications with us in advance. The design and specifications in this catalog are subject to change without prior notice.
- Do not use the products beyond the specifications described in this catalog.
- This catalog explains the quality and performance of the products as individual components. Before use, check and evaluate their operations when installed in your products under the actual conditions for use.
- Install the following systems for a failsafe design to ensure safety if these products are to be used in equipment where a defect in these products may cause the loss of human life or other significant damage, such as damage to vehicles (automobile, train, vessel), traffic lights, medical equipment, aerospace equipment, electric heating appliances, combustion/gas equipment, rotating equipment, and disaster/crime prevention equipment.
- * Systems equipped with a protection circuit and a protection device.
- * Systems equipped with a redundant circuit or other system to prevent an unsafe status in the event of a single fault.
- * Systems equipped with an arresting the spread of fire or preventing glitch.

(1) Precautions for use

- These products are designed and manufactured for general and standard use in general electronic equipment. (e.g. AV equipment, home electric appliances, office equipment, information and communication equipment) For applications in which special quality and reliability are required, or if the failure or malfunction of the products may directly jeopardize life or cause threat of personal injury (such as for aircraft and aerospace equipment, traffic and transport equipment, combustion equipment, medical equipment, accident prevention and anti-theft devices, and safety equipment), please be sure to consult with our sales representative in advance and to exchange product specifications which conform to such applications.
- These products are not intended for use in the following special conditions. Before using the products, carefully check the effects on their quality and performance, and determine whether or not they can be used.
 1. In liquid, such as water, oil, chemicals, or organic solvent.
 2. In direct sunlight, outdoors, or in dust.
 3. In salty air or air with a high concentration of corrosive gas, such as Cl_2 , H_2S , NH_3 , SO_2 , or NO_x .
 4. Electric Static Discharge (ESD) Environment.

These components are sensitive to static electricity and can be damaged under static shock (ESD). Please take measures to avoid any of these environments.
Smaller components are more sensitive to ESD environment.
 5. Electromagnetic and Radioactive Environment.

Avoid any environment where strong electromagnetic waves and radiation exist.
 6. In an environment where these products cause dew condensation.
 7. Sealing or coating of these products or a printed circuit board on which these products are mounted, with resin or other materials.
- These products generate Joule heat when energized. Carefully position these products so that their heat will not affect the other components.
- Carefully position these products so that their temperatures will not exceed the category temperature range due to the effects of neighboring heat-generating components. Do not mount or place heat-generating components or inflammables, such as vinyl-coated wires, near these products.
- Note that non-cleaning solder, halogen-based highly active flux, or water-soluble flux may deteriorate the performance or reliability of the products.
- Carefully select a flux cleaning agent for use after soldering. An unsuitable agent may deteriorate the performance or reliability. In particular, when using water or a water-soluble cleaning agent, be careful not to leave water residues. Otherwise, the insulation performance may be deteriorated.
- Do not apply flux to these products after soldering. The activity of flux may be a cause of failures in these products.
- Refer to the recommended soldering conditions and set the soldering condition. High peak temperature or long heating time may impair the performance or the reliability of these products.
- Recommended soldering condition is for the guideline for ensuring the basic characteristics of the products, not for the stable soldering conditions. Conditions for proper soldering should be set up according to individual conditions.

- Do not reuse any products after removal from mounting boards.
- Do not drop these products. If these products are dropped, do not use them. Such products may have received mechanical or electrical damage.
- If any doubt or concern to the safety on these products arise, make sure to inform us immediately and conduct technical examinations at your side.

(2) Precautions for storage

The performance of these products, including the solderability, is guaranteed for a year from the date of arrival at your company, provided that they remain packed as they were when delivered and stored at a temperature of 5 °C to 35 °C and a relative humidity of 45 % to 85 %.

The performance of Thermal Cutoffs is guaranteed for a year after our delivery, provided that they are stored at a temperature of -10 °C to +40 °C and a relative humidity of 30 % to 75 %.

Even within the above guarantee periods, do not store these products in the following conditions.

Otherwise, their electrical performance and/or solderability may be deteriorated, and the packaging materials (e.g. taping materials) may be deformed or deteriorated, resulting in mounting failures.

1. In salty air or in air with a high concentration of corrosive gas, such as Cl₂, H₂S, NH₃, SO₂, or NO_x.
2. In direct sunlight.

(3) Precaution specific to this product

1. Set the rated current so that the current passing through the Micro Chip Fuses (hereafter called the fuses) under normal conditions is within 70% of the rated current.
2. Do not continuously pass a current exceeding the rated current through the fuses.
3. If a pulse exceeding the rated current is applied, such as a rush current or surge current at power-on, take care not to cause unwanted fusing. Calculate the I²t value of the pulse and check the tolerance to the number of pulses according to the I²t-t characteristic curve before deciding to use the fuses. Before checking the tolerance, consult our sales staff in advance.
4. The fuses are designed to be blown out by a current that is double or greater than the rated current. Ensure that the abnormal current generated when a circuit abnormality occurs in your product is at least double or greater than the rated current of the fuses. In addition, ensure that the abnormal current of your product does not exceed the maximum interrupting current of the fuses.
5. The fuses are designed to be used on the secondary side of a power supply. Do not use them on the primary side.
6. Ensure that the voltage applied to the fuses are within their rated voltage.
7. The fusing characteristics of the fuses are affected by the ambient temperature. Before use, mount the fuses on your products and carefully check and evaluate their category temperature range.

<Package markings>

Package markings include the product number, quantity, and country of origin.

In principle, the country of origin should be indicated in English.

X-ON Electronics

Largest Supplier of Electrical and Electronic Components

Click to view similar products for [Surface Mount Fuses](#) category:

Click to view products by [Panasonic](#) manufacturer:

Other Similar products are found below :

[FHC20402ADTP](#) [NFVC6125S0R50TRF](#) [SFT-125MA](#) [TF16SN2.00TTD](#) [TR/3216LR-500MA](#) [CCP2B20TTE](#) [FCC16501ABTP](#) [0308.250UR](#)
[0308.375UR](#) [0308.500UR](#) [0308.750UR](#) [030801.5UR](#) [03081.25UR](#) [F0603G0R03FNTR](#) [SKY87604-11](#) [3404.0110.22](#) [SEF 0.375A 125V \(G\)](#)
[1211015](#) [S1206-F-3.0A](#) [9321315278](#) [S0603-F-4.0A](#) [SMT1315AP](#) [0603TD-4A](#) [1240FH-30A](#) [R451003.L](#) [R451.500L](#) [R451001.L](#) [3-103-119](#)
[3-103-123](#) [3-103-127](#) [0154002.DRL](#) [0154008.DRL](#) [0154.500DRL](#) [189140.1,25](#) [189140.0,8](#) [189140.0,4](#) [189140.0,63](#) [189140.0,25](#)
[0468003.WR](#) [0494001.NRHF](#) [0494002.NRHF](#) [0494003.NRHF](#) [049402.5NRHF](#) [049403.5NRHF](#) [0494.250NRHF](#) [0494.375NRHF](#)
[0494.500NRHF](#) [CF06V3T1R60](#) [CF06V3T2R50](#) [06H1300D](#)