

NEW! PAN1721 SERIES **BLUETOOTH**[®] LOW ENERGY

Ultra Low Power, *Bluetooth* Low Energy Module

Introducing the **PAN1721**, a complete power optimized *Bluetooth* v4.0 Low Energy (BLE) solution, this module includes an embedded processor, antenna and BLE stack. The **PAN1721** is engineered for ultra low power consumption applications.

The **PAN1721** is a cost-effective, ultra low-power, system-on-chip (SoC) for *Bluetooth* Low Energy applications. The module includes an eight channel, twelve bit analog-to-digital converter, 19 GPIOs plus battery and temperature sensors. A single device for both BLE master or slave nodes. The **PAN1721** combines an excellent RF transceiver with a high performance low power 8051 microcontroller, in-system programmable flash memory, 8-KB RAM, and many other powerful supporting features and peripherals.

The **PAN1721** is an ideal choice for applications where battery life is a critical application requirement, using only 500 nA in sleep mode. Short transition times between operating modes—3 uS Wake-Up – and power efficient hardware further reduce current consumption.

Panasonic offers *Bluetooth* Low Energy protocol stacks and applications from Texas Instruments and *BlueRadios*[™]. The *BlueRadios* stack enables rapid and low cost development using an AT command set without the need for a compiler. Additional advantages include UART programming, over-the-air-updates, easy integration “C” library framework, serial streaming of data, and smart phone libraries and applications.

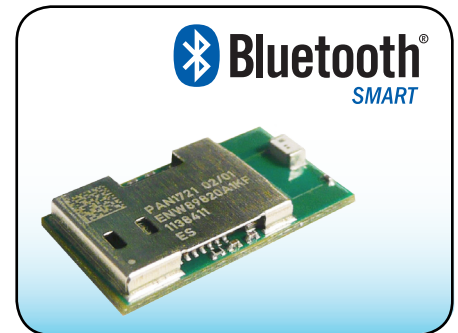

Product Performance:

- *Bluetooth* 4.0 Compliant and *Bluetooth* Low Energy
- Dimensions: 14.5x 8.2 x 3 mm
- Supports User Developed Applications
- Texas Instruments' Stack or Optional *BlueRadios* Stack
- 256K Flash, 8K RAM
- Supports 1 Mbps Data Rate
- Temperature Range -40°C to +85°C
- Eight Channel 12-Bit ADC
- 19 GPIOs
- Battery Monitor and Temperature Sensor

PAN1721/1711 Part Numbers:

Part Numbers	Description
ENW-89835A1KF	PAN1721, CC2541 <i>Bluetooth</i> Low Energy with 8051 Controller, Texas Instruments Stack
ENW-89835A3KF	PAN1721, CC2541 <i>Bluetooth</i> Low Energy with 8051 Controller, <i>BlueRadios</i> Stack
ENW-89835C1KF	PAN1711, CC2541 <i>Bluetooth</i> Low Energy with 8051 Controller, Texas Instruments Stack
ENW-89835C3KF	PAN1711, CC2541 <i>Bluetooth</i> Low Energy with 8051 Controller, <i>BlueRadios</i> Stack
EVAL_PAN1721	<i>Bluetooth</i> , PAN1721, Evaluation Kit, Includes Two PAN1721 USB Development Modules
EVAL_PAN1721BR	<i>Bluetooth</i> , PAN1721, Evaluation Kit, Includes Two PAN1721 USB Development Modules, <i>BlueRadios</i> FW

Alternative Low Energy Device:

Part Numbers	Description
ENW-89823A2JF	PAN1326, CC2564, <i>Bluetooth</i> & <i>Bluetooth</i> Low Energy, HCI Module, Antenna

The *Bluetooth*[®] word mark and logos are registered trademarks owned by Bluetooth SIG, Inc. and any use of such marks by Panasonic Corporation of North America is under license. Other trademarks and trade names are those of their respective owners.



Interfaces:

The PAN1721 Interface supports:

- Two Powerful USARTs with Support for Several Serial Protocols
- I2C Interface
- 19 General-Purpose I/O Pins (17x4mA, 2x20mA)
- 12-Bit ADC with Eight Channels and Configurable Resolution

Applications:

- 2.4 GHz *Bluetooth* Low Energy Systems
- Proprietary 2.4 GHz Systems
- Human Interface Devices
- Sports and Leisure Equipment
- Mobile Phone Accessories
- Consumer Electronics
- USB Dongles
- Health Care and Medical

Block Diagram PAN1721/PAN1711:

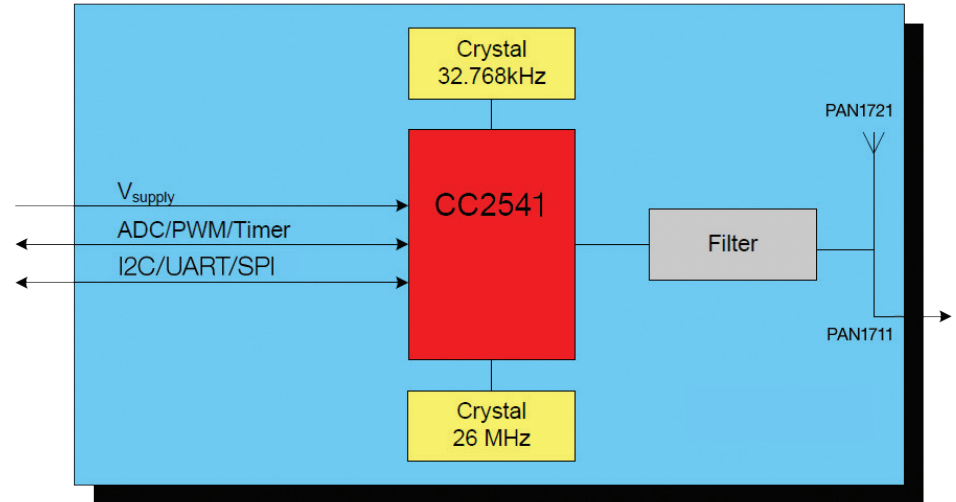

Evaluation Kits:

EVAL_PAN1721

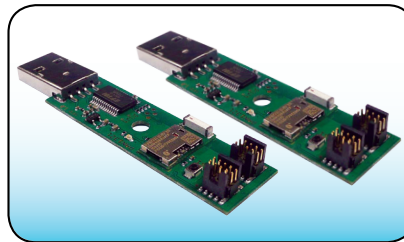

EVAL_PAN1721BR



Technical Specifications for PAN1721:

Parameter	Value	Condition / Notes
Receiver Sensitivity (1% PER)	-96 dBm	@ 500 kbps / MSK (High-Gain Mode)
Output Power	0 dBm typ.	Maximum Setting
Power Supply	2.0 - 3.6 V	Single Operation Voltage
Sleep Mode	0.5 μ A	Power Mode 3 (Lowest)
Transmit Mode	14 mA	@ 0dBm (Peak Current)
Receive Mode	14.7 mA	Standard Mode
Operating Temperature Range	-40°C to +85°C	Industrial Range

The *Bluetooth*® word mark and logos are registered trademarks owned by Bluetooth SIG, Inc. and any use of such marks by Panasonic Corporation of North America is under license. Other trademarks and trade names are those of their respective owners.



X-ON Electronics

Largest Supplier of Electrical and Electronic Components

Click to view similar products for [Bluetooth Development Tools - 802.15.1 category](#):

Click to view products by [Panasonic manufacturer](#):

Other Similar products are found below :

[DA14580PRODTLKT](#) [1628](#) [SP14808ST](#) [MBH7BLZ02-EF-KIT](#) [CYBLE-014008-PROG](#) [FWM7BLZ20-EB-KIT](#) [SP14801-DUT](#)
[ATSAMB11ZR-XPRO](#) [SKY66111-21EK1](#) [SECO-RSL10-TAG-GEVB](#) [ENW89857AXKF](#) [3026](#) [MIKROE-2471](#) [MOD-NRF8001](#) [BLE-IOT-GEVB](#) [450-0184](#) [EKSHCNZXZ](#) [EVAL_PAN1026](#) [EVAL_PAN1720](#) [EVAL_PAN1740](#) [2267](#) [2479](#) [2487](#) [2633](#) [STEVAL-IDB005V1D](#)
[STEVAL-IDB001V1](#) [MIKROE-2545](#) [SIPKITSLF001](#) [2995](#) [STEVAL-IDB007V1M](#) [2829](#) [DFR0267](#) [DFR0296](#) [DFR0492](#) [TEL0073](#) [BM-70-CDB](#) [WSM-BL241-ADA-008DK](#) [STEVAL-BTDP1](#) [ACD52832](#) [TEL0095](#) [ISP1507-AX-TB](#) [RN-4871-PICTAIL](#) [DA14695-00HQDEVKT-P](#)
[DA14695-00HQDEVKT-U](#) [EVK-NINA-B112](#) [EBSHJNZXZ](#) [EKSGJNZWY](#) [EKSHJNZXZ](#) [BMD-200-EVAL-S](#) [ACN BREAKOUT BOARD](#)