

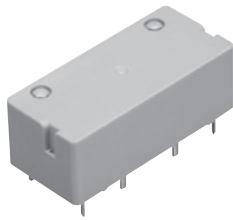

### 1a1b/2a 8A polarized power relays

## ST RELAYS



Protective construction: Sealed type

## FEATURES

- Even with small form factor, sensitive enough for direct IC driving**  
 The dimensions of this high-density 4-gap balanced armature are 31 mm 14 mm×11 mm 1.220 inch×.551 inch ×.433 inch. Despite this small size, high sensitivity is achieved by a mechanism that incorporates highefficiency polarized magnetic circuits along with our exclusive spring alignment method. With an minimum operating power of about 150 mW, nominal operating power of 240 mW, this relay can be directly driven by transistor or chip controllers.

- High switching capability**  
 High contact pressure, low contact bounce, and forced separation structure that radically improves resistance to contact welding (1 Form A 1 Form B type equivalent to TV-3). Strong against lamp inductive loads, maximum switching capacity has reached 3,040 VA (8A 380V AC).
- High breakdown voltage – Optimal for control in 250 V power circuits**  
 High breakdown voltage has been achieved. Between contacts and coil of 3,750 Vrms; Surge breakdown voltage between coil and contact of 6,000 V, and between open contacts of 1,200 Vrms mean that these relays are suitable even for 250 V power circuit control.
- Improved stability**  
**Conforms to all types of safety standards**  
 Insulating distance of more than 3 mm .118 inch secured. Complies with Japan Electrical Appliance and Material Safety Law requirements for operating 200 V power supply circuits, and conforms with UL, CSA and VDE standards.
- Latching types available**  
 In addition to single side stable types, convenient 2 coil latching types with memory functions are also available. Moreover, we offer 2 Form A specifications which, with double pole switching for applications such as 250 V power circuit switching, can enable safer designs.
- Automatic cleaning possible**  
 The sealed design means that these relays can undergo immersion in automatic washing systems and are suitable for automatic soldering. Even in difficult environments, the contacts remain reliable.
- Easy to design PC board patterns**  
 Features 4/10 dual-in-line terminals. Because the lead spacing has a pitch greater than 7.54 mm .297 inch, designers can make easy adjustments with the width of the land size. This, along with the large insulation distance, simplifies the drawing of PC board patterns.
- To improve soldering efficiency, preapplication of solder to the terminals is recommended**
- Sockets for PC board and soldering are available**

## ORDERING INFORMATION

ST  -  -  - F

Contact arrangement

1: 1 Form A 1 Form B  
2: 2 Form A

Operating function

Nil: Single side stable  
L2: 2 coil latching

Nominal coil voltage

DC 3, 5, 6, 9, 12, 24, 48 V

Contact material

F: AgSnO<sub>2</sub> type contact

## TYPES

Contact arrangement	Nominal coil voltage	Single side stable	2 coil latching
		Part No.	Part No.
1 Form A 1 Form B	3V DC	ST1-DC3V-F	ST1-L2-DC3V-F
	5V DC	ST1-DC5V-F	ST1-L2-DC5V-F
	6V DC	ST1-DC6V-F	ST1-L2-DC6V-F
	9V DC	ST1-DC9V-F	ST1-L2-DC9V-F
	12V DC	ST1-DC12V-F	ST1-L2-DC12V-F
	24V DC	ST1-DC24V-F	ST1-L2-DC24V-F
	48V DC	ST1-DC48V-F	ST1-L2-DC48V-F
2 Form A	3V DC	ST2-DC3V-F	ST2-L2-DC3V-F
	5V DC	ST2-DC5V-F	ST2-L2-DC5V-F
	6V DC	ST2-DC6V-F	ST2-L2-DC6V-F
	9V DC	ST2-DC9V-F	ST2-L2-DC9V-F
	12V DC	ST2-DC12V-F	ST2-L2-DC12V-F
	24V DC	ST2-DC24V-F	ST2-L2-DC24V-F
	48V DC	ST2-DC48V-F	ST2-L2-DC48V-F

Standard packing: Carton: 50 pcs.; Case: 500 pcs.

\* Terminal sockets available.

## RATING

### 1. Coil data

- Operating characteristics such as 'Operate voltage' and 'Release voltage' are influenced by mounting conditions, ambient temperature, etc. Therefore, please use the relay within  $\pm 5\%$  of rated coil voltage.
- 'Initial' means the condition of products at the time of delivery.

#### 1) Single side stable

Nominal coil voltage	Pick-up voltage (at 20°C 68°F)	Drop-out voltage (at 20°C 68°F)	Nominal operating current [ $\pm 10\%$ ] (at 20°C 68°F)	Coil resistance [ $\pm 10\%$ ] (at 20°C 68°F)	Nominal operating power	Max. applied voltage (at 20°C 68°F)
3V DC	80%V or less of nominal voltage (Initial)	10%V or more of nominal voltage (Initial)	75mA	38 $\Omega$	Approx. 240mW	150%V of nominal voltage
5V DC			47mA	105 $\Omega$		
6V DC			40mA	150 $\Omega$		
9V DC			25mA	360 $\Omega$		
12V DC			20mA	600 $\Omega$		
24V DC			10mA	2,400 $\Omega$		
48V DC			4.7mA	9,000 $\Omega$		

#### 2) 2 coil latching

Nominal coil voltage	Set voltage (at 20°C 68°F)	Reset voltage (at 20°C 68°F)	Nominal operating current [ $\pm 10\%$ ] (at 20°C 68°F)		Coil resistance [ $\pm 10\%$ ] (at 20°C 68°F)		Nominal operating power		Max. applied voltage (at 20°C 68°F)
			Set coil	Reset coil	Set coil	Reset coil	Set coil	Reset coil	
3V DC	80%V or less of nominal voltage (Initial)	80%V or less of nominal voltage (Initial)	75mA	75mA	40 $\Omega$	40 $\Omega$	Approx. 240mW	Approx. 240mW	150%V of nominal voltage
5V DC			45mA	45mA	110 $\Omega$	110 $\Omega$			
6V DC			37.5mA	37.5mA	155 $\Omega$	155 $\Omega$			
9V DC			25mA	25mA	360 $\Omega$	360 $\Omega$			
12V DC			18.8mA	18.8mA	640 $\Omega$	640 $\Omega$			
24V DC			10mA	10mA	2,400 $\Omega$	2,400 $\Omega$			
48V DC			4.7mA	4.7mA	10,200 $\Omega$	10,200 $\Omega$			

2. Specifications

Characteristics	Item	Specifications	
Contact	Arrangement	1 Form A 1 Form B, 2 Form A	
	Contact material	Au-flashed AgSnO <sub>2</sub> type	
	Contact resistance (Initial)	Max. 30 mΩ (By voltage drop 6 V DC 1A)	
Rating	Max. switching power (resistive load)	3,040 VA, 150 W	
	Max. switching voltage	380 V AC, 250 V DC	
	Max. switching current	8 A	
	Min. switching capacity (Reference value)*1	100 mA 5V DC	
Electrical characteristics	Insulation resistance (Initial) (at 25°C, 50% relative humidity)	Min. 1,000MΩ (at 500V DC) Measurement at same location as "Breakdown voltage" section.	
	Breakdown voltage (Initial)	Between open contacts	1,200 Vrms for 1 min. (Detection current: 10 mA)
		Between contact sets	2,000 Vrms for 1 min. (Detection current: 10 mA)
		Between contact and coil	3,750 Vrms for 1 min. (Detection current: 10 mA)
	Surge breakdown voltage (Initial)*2	6,000 V (Between contact and coil)	
	Operate time [Set time] (at 20°C 68°F)	Max. 15 ms [Max. 15 ms] (Nominal coil voltage applied to the coil, excluding contact bounce time.)	
Release time [Reset time] (at 20°C 68°F)	Max. 10 ms [Max. 15 ms] (Nominal coil voltage applied to the coil, excluding contact bounce time.) (without diode)		
Mechanical characteristics	Shock resistance	Functional	Min. 196 m/s <sup>2</sup> (Half-wave pulse of sine wave: 11 ms; detection time: 10μs.)
		Destructive	Min. 980 m/s <sup>2</sup> (Half-wave pulse of sine wave: 6 ms.)
	Vibration resistance	Functional	10 to 55 Hz at double amplitude of 2 mm (Detection time: 10μs.)
		Destructive	10 to 55 Hz at double amplitude of 3 mm
Expected life	Mechanical	Min. 10 <sup>7</sup> (at 180 times/min.)	
Conditions	Conditions for operation, transport and storage*3	Ambient temperature: -40°C to +60°C -40°F to +140°F; Humidity: 5 to 85% R.H. (Not freezing and condensing at low temperature)	
Unit weight		Approx. 10g .353 oz	

Notes: \*1. This value can change due to the switching frequency, environmental conditions, and desired reliability level, therefore it is recommended to check this with the actual load.

\*2. Wave is standard shock voltage of ±1.2×50μs according to JEC-212-1981

\*3. The upper limit of the ambient temperature is the maximum temperature that can satisfy the coil temperature rise value. Refer to Usage, transport and storage conditions in NOTES.

3. Electrical life

Condition: Resistive load , ON : OFF=1s : 5s

Types	Switching capacity	No. of operations
1 Form A 1 Form B, 2 Form A	8A 250V AC	Min. 1×10 <sup>5</sup>

REFERENCE DATA

1. Max. switching power

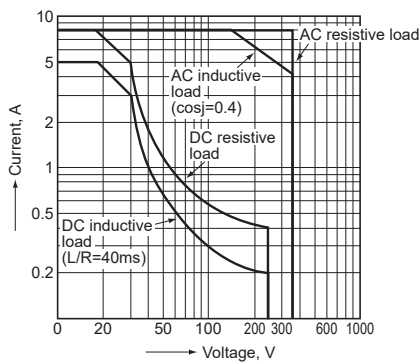

2. Coil temperature rise

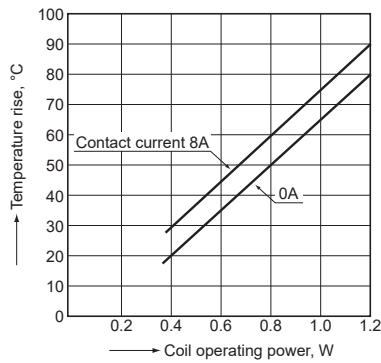

3. Influence of adjacent mounting

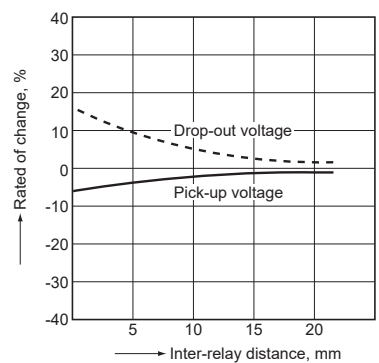

**DIMENSIONS** (mm inch)

**CAD** The CAD data of the products with a "CAD" mark can be downloaded from our Website.

**CAD**

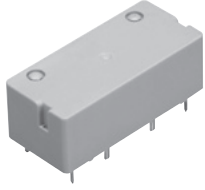

**External dimensions**

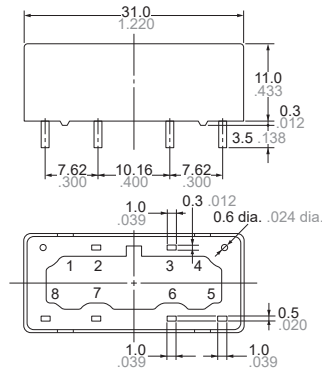

**PC board pattern (Bottom view)**

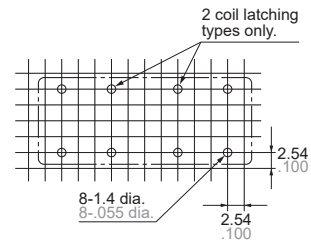

Tolerance:  $\pm 0.1 \pm 0.04$

General tolerance:  $\pm 0.5 \pm 0.020$

**Schematic (Bottom view)**

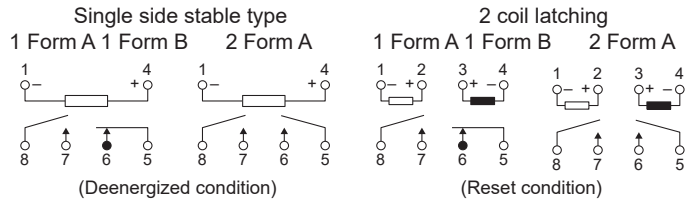

**SAFETY STANDARDS**

UL (Recognized)		CSA (Certified)		VDE (Certified)		TV rating (UL/CSA)	
File No.	Contact rating	File No.	Contact rating	File No.	Contact rating	File No.	Rating
E43028	8A 250V AC	LR26550	8A 250V AC	40017740	8A 250V AC ( $\cos\phi = 1.0$ )	UL: E43028	TV-3
	5A 30V DC		5A 30V DC		5A 30V DC (0ms)		
	1/4HP 125, 250V AC		1/4HP 125, 250V AC		4A 250V AC ( $\cos\phi = 0.4$ )	CSA: LR26550	TV-3

**EN/IEC VDE Certified  
INSULATION CHARACTERISTICS (IEC61810-1)**

Item	Characteristics
Clearance/Creepage distance (IEC61810-1)	Min. 1.5/2.5mm
Category of protection (IEC61810-1)	RT III
Tracking resistance (IEC60112)	PTI 100
Insulation material group	III a
Over voltage category	II
Rated voltage	250V
Pollution degree	2
Type of insulation (Between contact and coil)	Basic insulation
Type of insulation (Between open contacts)	Micro disconnection

## NOTES

1. For cautions for use, please read "GENERAL APPLICATION GUIDELINES".

2. PC board patterns for 2 coil latching types

When applying relays in power supply operation circuits for finished products regulated by the Electrical Appliance and Material Safety Law, use the pattern shown below.

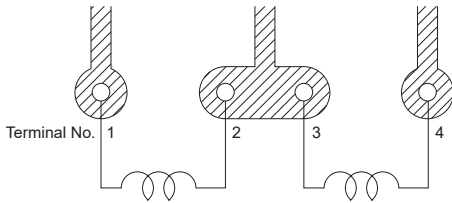

3. Soldering should be done under the following conditions:

- 1) 250°C 482°F within 10s  
300°C 572°F within 5s  
350°C 662°F within 3s
- 2) For automatic cleaning, the boiling method is recommended. Avoid ultrasonic cleaning which subjects the relays to high frequency vibrations, which may cause the contacts to stick. It is recommended that a fluorinated hydrocarbon or other alcoholic solvents be used.

4. When using, please be aware that the a contact and b contact sides of 1 Form A 1 Form B type may go on simultaneously at operate time and release time.

Please refer to "the latest product specifications" when designing your product.

- Requests to customers :  
<https://industrial.panasonic.com/ac/e/salespolicies/>

# ACCESSORIES

# ST RELAYS TERMINAL SOCKETS

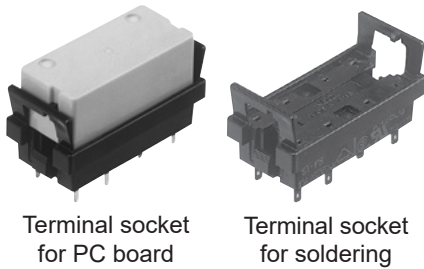

Terminal socket for PC board

Terminal socket for soldering

## TYPES

Product name	Part No.
Terminal socket for PC board	ST-PS
Terminal socket for soldering	ST-SS

## FEATURES

- Possible to fit or remove the chassis with one touch ( $t = 0.6 \text{ mm to } 2.2 \text{ mm}$  .024 inch to .087 inch)
- Easy design of PC board pattern (2.54 mm x 4 pitch DIL terminal array)
- High breakdown voltage.

## PRECAUTIONS FOR USE (SOCKET)

### 1. PC board mounting method

PC board pattern

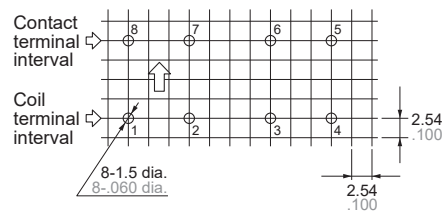

The terminal configuration is symmetrical on the left and right, so an arrow mark  is stamped on the socket to prevent misinsertion.

We recommend printing the same arrow mark  on the component mounting side (side opposite from pattern) of the PC board. In this case, the terminal configuration becomes the terminal nos. noted near the drilling holes.

### 2. Chassis cutout

Chassis cutting dimensions

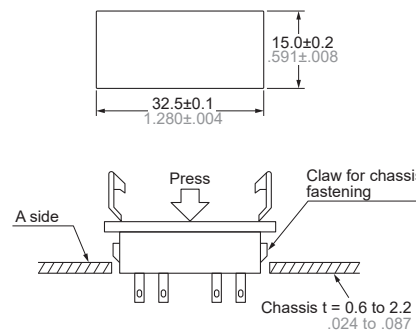

If the chassis hole is punched with a press, set so the release R on the front side (A side). The range for chassis thickness is 0.6 to 2.2 mm .024 to .087 inch.

**CAD** The CAD data of the products with a "CAD" mark can be downloaded from our Website.

## SPECIFICATIONS

Item	Specifications
Breakdown voltage (Initial)	Between contact and coil: 4,000 Vrms for 1 min. (Detection current: 10 mA) Between contact and terminal: 2,000 Vrms for 1 min.
Insulation resistance (Initial)	Min. 1,000 MΩ between terminals (500V DC)
Heat resistance	150°C 302°F for 1 hr
Max. continuous current	10 A
Relay insertion life	15 times

## DIMENSIONS (mm inch)

Terminal socket for PC board

**CAD**

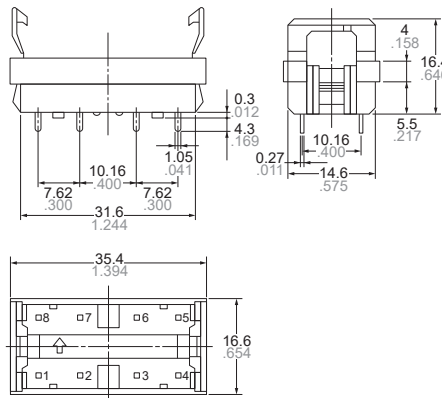

Terminal socket for soldering

**CAD**

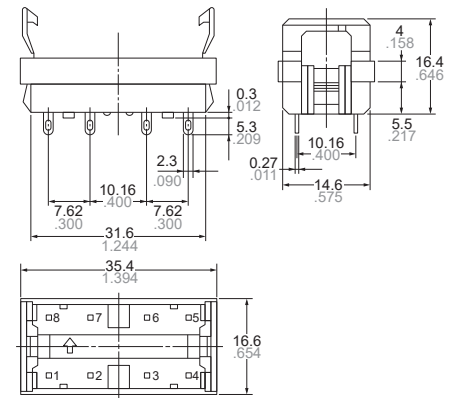

### 3. Relay mounting and removal

(1) Align the directions of the relay and socket.

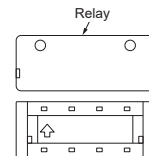

(2) Insert the relay all the way in, so it is securely in place.

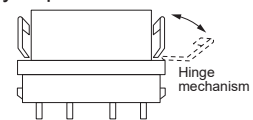

(3) Press the part indicated by A in the B direction, and fasten by placing the hook on the relay.

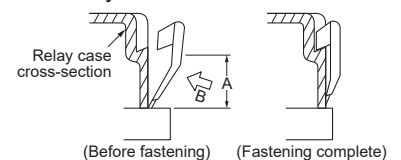

(4) When removing the relay, completely release the hooks on both sides and pull the relay out.

# GUIDELINES FOR POWER RELAYS AND HIGH-CAPACITY DC CUT OFF RELAYS USAGE

For cautions for use, please read “GUIDELINES FOR RELAY USAGE”.

[https://industrial.panasonic.com/ac/e/control/relay/cautions\\_use/index.jsp](https://industrial.panasonic.com/ac/e/control/relay/cautions_use/index.jsp)

## Precautions for Coil Input

### ■ Long term current carrying

A circuit that will be carrying a current continuously for long periods without relay switching operation. (circuits for emergency lamps, alarm devices and error inspection that, for example, revert only during malfunction and output warnings with form B contacts) Continuous, long-term current to the coil will facilitate deterioration of coil insulation and characteristics due to heating of the coil itself.

For circuits such as these, please use a magnetic-hold type latching relay. If you need to use a single stable relay, use a sealed type relay that is not easily affected by ambient conditions and make a failsafe circuit design that considers the possibility of contact failure or disconnection.

### ■ DC Coil operating power

Steady state DC current should be applied to the coil. The wave form should be rectangular. If it includes ripple, the ripple factor should be less than 5%.

However, please check with the actual circuit since the electrical characteristics may vary. The rated coil voltage should be applied to the coil and the set/reset pulse time of latching type relay differs for each relays, please refer to the relay's individual specifications.

### ■ Coil connection

When connecting coils of polarized relays, please check coil polarity (+,-) at the internal connection diagram (Schematic). If any wrong connection is made, it may cause unexpected malfunction, like abnormal heat, fire and so on, and circuit do not work. Avoid impressing voltages to the set coil and reset coil at the same time.

## Ambient Environment

### ● Usage, Transport, and Storage Conditions

During usage, storage, or transportation, avoid locations subjected to direct sunlight and maintain normal temperature, humidity and pressure conditions.

### ● Temperature/Humidity/Pressure

When transporting or storing relays while they are tube packaged, there are cases the temperature may differ from the allowable range. In this case be sure to check the individual specifications. Also allowable humidity level is influenced by temperature, please check charts shown below and use relays within mentioned conditions. (Allowable temperature values differ for each relays, please refer to the relay's individual specifications.)

#### 1) Temperature:

The tolerance temperature range differs for each relays, please refer to the relay's individual specifications

#### 2) Humidity:

5 to 85 % RH

#### 3) Pressure:

86 to 106 kPa

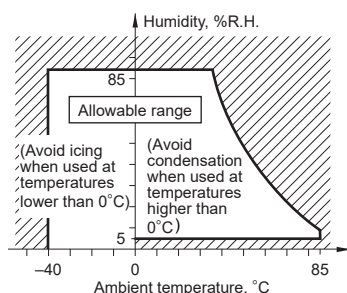

### ■ Maximum allowable voltage and temperature rise

Proper usage requires that the rated coil voltage be impressed on the coil. Note, however, that if a voltage greater than or equal to the maximum continuous voltage is impressed on the coil, the coil may burn or its layers short due to the temperature rise. Furthermore, do not exceed the usable ambient temperature range listed in the catalog.

### ■ Operate voltage change due to coil temperature rise (Hot start)

In DC relays, after continuous passage of current in the coil, if the current is turned OFF, then immediately turned ON again, due to the temperature rise in the coil, the pick-up voltage will become somewhat higher. Also, it will be the same as using it in a higher temperature atmosphere. The resistance/temperature relationship for copper wire is about 0.4% for 1°C, and with this ratio the coil resistance increases. That is, in order to operate of the relay, it is necessary that the voltage be higher than the pick-up voltage and the pick-up voltage rises in accordance with the increase in the resistance value. However, for some polarized relays, this rate of change is considerably smaller.

### ● Dew condensation

Condensation occurs when the ambient temperature drops suddenly from a high temperature and humidity, or the relay is suddenly transferred from a low ambient temperature to a high temperature and humidity. Condensation causes the failures like insulation deterioration, wire disconnection and rust etc. Panasonic Corporation does not guarantee the failures caused by condensation.

The heat conduction by the equipment may accelerate the cooling of device itself, and the condensation may occur.

Please conduct product evaluations in the worst condition of the actual usage. (Special attention should be paid when high temperature heating parts are close to the device. Also please consider the condensation may occur inside of the device.)

### ● Icing

Condensation or other moisture may freeze on relays when the temperature become lower than 0°C. This icing causes the sticking of movable portion, the operation delay and the contact conduction failure etc. Panasonic Corporation does not guarantee the failures caused by the icing.

The heat conduction by the equipment may accelerate the cooling of relay itself and the icing may occur. Please conduct product evaluations in the worst condition of the actual usage.

### ● Low temperature and low humidity

The plastic becomes brittle if the switch is exposed to a low temperature, low humidity environment for long periods of time.

### ● High temperature and high humidity

Storage for extended periods of time (including transportation periods) at high temperature or high humidity levels or in atmospheres with organic gases or sulfide gases may cause a sulfide film or oxide film to form on the surfaces of the contacts and/or it may interfere with the functions. Check out the atmosphere in which the units are to be stored and transported.

# GUIDELINES FOR POWER RELAYS AND HIGH-CAPACITY DC CUT OFF RELAYS USAGE

## ●Package

In terms of the packing format used, make every effort to keep the effects of moisture, organic gases and sulfide gases to the absolute minimum.

## ●Silicon

When a source of silicone substances (silicone rubber, silicone oil, silicone coating materials and silicone filling materials etc.) is used around the relay, the silicone gas (low molecular siloxane etc.) may be produced.

This silicone gas may penetrate into the inside of the relay. When the relay is kept and used in this condition, silicone compound may adhere to the relay contacts which may cause the contact failure. Do not use any sources of silicone gas around the relay (Including plastic seal types).

## ●NOx Generation

When relay is used in an atmosphere high in humidity to switch a load which easily produces an arc, the NOx created by the arc and the water absorbed from outside the relay combine to produce nitric acid. This corrodes the internal metal parts and adversely affects operation. Avoid use at an ambient humidity of 85%RH or higher (at 20°C). If use at high humidity is unavoidable, please contact our sales representative.

## Others

### ■Cleaning

- 1) Although the environmentally sealed type relay (plastic sealed type, etc.) can be cleaned, avoid immersing the relay into cold liquid (such as cleaning solvent) immediately after soldering. Doing so may deteriorate the sealing performance.
- 2) Cleaning with the boiling method is recommended(The temperature of cleaning liquid should be 40°C or lower ).  
Avoid ultrasonic cleaning on relays. Use of ultrasonic cleaning may cause breaks in the coil or slight sticking of the contacts due to ultrasonic energy.

Please refer to **"the latest product specifications"** when designing your product.

•Requests to customers:

<https://industrial.panasonic.com/ac/e/salespolicies/>



---

Please contact .....

**Panasonic Corporation**

Electromechanical Control Business Division

■ 1006, Oaza Kadoma, Kadoma-shi, Osaka 571-8506, Japan  
[industrial.panasonic.com/ac/e/](http://industrial.panasonic.com/ac/e/)

**Panasonic**<sup>®</sup>

©Panasonic Corporation 2019

## X-ON Electronics

Largest Supplier of Electrical and Electronic Components

*Click to view similar products for [Relay Sockets & Fixings](#) category:*

*Click to view products by [Panasonic](#) manufacturer:*

Other Similar products are found below :

[00008258500](#) [00111976502](#) [0000-825-81-00](#) [60SY4S05](#) [M41G](#) [670-0125](#) [670-0127](#) [6700152](#) [670-0153](#) [6700156](#) [D258-2TS00](#) [70-309](#) [7-1393143-3](#) [7-1616360-5](#) [8000-DG2-5](#) [911361](#) [9-1616339-5](#) [PJF11N](#) [GDA12HA](#) [GDA12HD](#) [GDA12SA](#) [GDA12SD](#) [GDA16HD](#) [GDA22HA](#) [GDA95A](#) [GDA95D](#) [GFX20](#) [PT08QN](#) [PT 1/8 D = 3.2](#) [GUA1](#) [GUA2-11](#) [GUA4-04](#) [GUA4-31](#) [GUM5R](#) [GUR-120](#) [GUR-24](#) [GUR-240](#) [GUR-277](#) [GURX-277](#) [GUW12](#) [GUW95](#) [GUZ63L](#) [R99-11 FOR MY\(NAMEPLATE\)](#) [D52PR2T](#) [RES100K](#) [1310H-HDC](#) [1390H-1ST](#) [1393824-3](#) [1390H-2PC](#) [1410-2SM](#)