

For operation: Snap Switches  
**T-15 Series Switches**

Product Catalog

**IN Your  
Future**

# T-15 Series Switches

## Snap Switches Capable of 15 A Switching

(Unit: mm)

**FEATURES**

- Rocker and push-button switches included in product lineup
- Sealed type available for use in different environments
- Rubber cap also available in silicon type for excellent weather resistance

**\*These switches are only for industrial use.  
Do not use any other applications. (ex. home use)**

### ASSORTMENT

Protection grade Number of pole Shape of terminal Operation shape	Standard type	Sealed type			Number of pole				Shape of terminal			
		Panel-sealed type	Terminal-sealed type	Wire leads type	1P	2P	3P	4P	Solder terminal	Screw terminal	.250 Quick-connect terminal	Wire lead
Toggle type	Available	Available	Available	Available	Available	Available	Available*1	Available*1	Available	Available	Available*1	Available*2
Rocker type	Available	Available	Available	Available	Available	Available	-	-	Available	Available	-	Available*2
Push-button type	Available	Available	-	-	Available	Available	-	-	Available	Available	-	-

Notes: \*1: Only standard type (exclude sealed type)  
\*2: Only wire leads type

## ORDERING INFORMATION (PART NO.)

### Toggle types

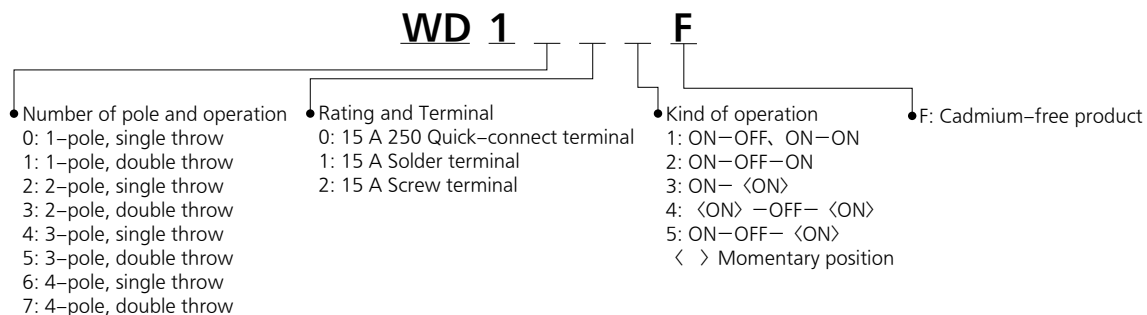

### Toggle switch waterproof types

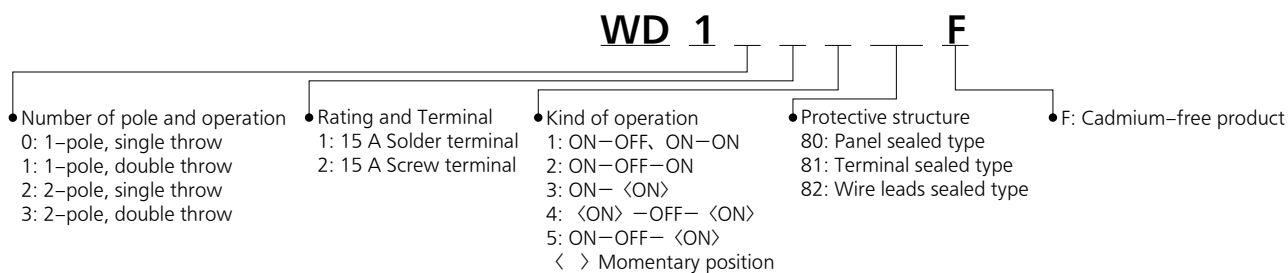

## TYPES

## ■ Toggle types



## ● Standard type

## 1) Solder terminal and .250 Quick-connect terminal

Number of poles	Kind of operation < >: Momentary position	Solder terminal		Products subject to the Electrical Appliances and Material Safety Act	.250 Quick-connect terminal		Products subject to the Electrical Appliances and Material Safety Act
		Type No.	Part No.		Type No.	Part No.	
1-pole	ON-OFF	T115A-F	WD1011F	-	T115A-AF	WD1001F	-
	ON-ON	T115D-F	WD1111F	-	T115D-AF	WD1101F	-
	ON-OFF-ON	T115E-F	WD1112F	-	T115E-AF	WD1102F	-
	ON-<ON>	T115F-F	WD1113F	-	T115F-AF	WD1103F	-
	<ON>-OFF-<ON>	T115G-F	WD1114F	-	T115G-AF	WD1104F	-
	ON-OFF-<ON>	T115H-F	WD1115F	-	T115H-AF	WD1105F	-
2-pole	ON-OFF	T215K-F	WD1211F	-	T215K-AF	WD1201F	-
	ON-ON	T215N-F	WD1311F	-	T215N-AF	WD1301F	-
	ON-OFF-ON	T215P-F	WD1312F	-	T215P-AF	WD1302F	-
	ON-<ON>	T215R-F	WD1313F	-	T215R-AF	WD1303F	-
	<ON>-OFF-<ON>	T215S-F	WD1314F	-	T215S-AF	WD1304F	-
	ON-OFF-<ON>	T215T-F	WD1315F	-	T215T-AF	WD1305F	-
3-pole	ON-OFF	T315K-F	WD1411F	-	T315K-AF	WD1401F	-
	ON-ON	T315N-F	WD1511F	-	T315N-AF	WD1501F	-
	ON-OFF-ON	T315P-F	WD1512F	-	T315P-AF	WD1502F	-
4-pole	ON-OFF	T415K-F	WD1611F	-	T415K-AF	WD1601F	-
	ON-ON	T415N-F	WD1711F	-	T415N-AF	WD1701F	-
	ON-OFF-ON	T415P-F	WD1712F	-	T415P-AF	WD1702F	-

Note: Standard installation accessories are included with the product.

## 2) Screw terminal

Number of poles	Kind of operation < >: Momentary position	Screw terminal		Products subject to the Electrical Appliances and Material Safety Act
		Type No.	Part No.	
1-pole	ON-OFF	T115A-SF	WD1021F	Available
	ON-ON	T115D-SF	WD1121F	Available
	ON-OFF-ON	T115E-SF	WD1122F	Available
	ON-<ON>	T115F-SF	WD1123F	Available
	<ON>-OFF-<ON>	T115G-SF	WD1124F	Available
	ON-OFF-<ON>	T115H-SF	WD1125F	Available
2-pole	ON-OFF	T215K-SF	WD1221F	Available
	ON-ON	T215N-SF	WD1321F	-
	ON-OFF-ON	T215P-SF	WD1322F	-
	ON-<ON>	T215R-SF	WD1323F	-
	<ON>-OFF-<ON>	T215S-SF	WD1324F	-
	ON-OFF-<ON>	T215T-SF	WD1325F	-
3-pole	ON-OFF	T315K-SF	WD1421F	-
	ON-ON	T315N-SF	WD1521F	-
	ON-OFF-ON	T315P-SF	WD1522F	-
4-pole	ON-OFF	T415K-SF	WD1621F	-
	ON-ON	T415N-SF	WD1721F	-
	ON-OFF-ON	T415P-SF	WD1722F	-

Note: Standard installation accessories are included with the product.

# T-15 Series Switches (WD1, WDR1, WDB1)

## ● Panel-sealed type

### 1) Solder terminal

Number of poles	Kind of operation < >: Momentary position	Solder terminal		Products subject to the Electrical Appliances and Material Safety Act
		Type No.	Part No.	
1-pole	ON-OFF	TP115A-F	WD101180F	-
	ON-ON	TP115D-F	WD111180F	-
	ON-OFF-ON	TP115E-F	WD111280F	-
	ON-<ON>	TP115F-F	WD111380F	-
	<ON>-OFF-<ON>	TP115G-F	WD111480F	-
	ON-OFF-<ON>	TP115H-F	WD111580F	-
2-pole	ON-OFF	TP215K-F	WD121180F	-
	ON-ON	TP215N-F	WD131180F	-
	ON-OFF-ON	TP215P-F	WD131280F	-
	ON-<ON>	TP215R-F	WD131380F	-
	<ON>-OFF-<ON>	TP215S-F	WD131480F	-
	ON-OFF-<ON>	TP215T-F	WD131580F	-

Note: Of the standard installation accessories that come with the product, the front hex nut and lock washer are included.

### 2) Screw terminal

Number of poles	Kind of operation < >: Momentary position	Screw terminal		Products subject to the Electrical Appliances and Material Safety Act
		Type No.	Part No.	
1-pole	ON-OFF	TP115A-SF	WD102180F	Available
	ON-ON	TP115D-SF	WD112180F	Available
	ON-OFF-ON	TP115E-SF	WD112280F	Available
	ON-<ON>	TP115F-SF	WD112380F	Available
	<ON>-OFF-<ON>	TP115G-SF	WD112480F	Available
	ON-OFF-<ON>	TP115H-SF	WD112580F	Available
2-pole	ON-OFF	TP215K-SF	WD122180F	Available
	ON-ON	TP215N-SF	WD132180F	-
	ON-OFF-ON	TP215P-SF	WD132280F	-
	ON-<ON>	TP215R-SF	WD132380F	-
	<ON>-OFF-<ON>	TP215S-SF	WD132480F	-
	ON-OFF-<ON>	TP215T-SF	WD132580F	-

Note: Of the standard installation accessories that come with the product, the front hex nut and lock washer are included.

## ● Terminal-sealed type

## 1) Solder terminal

Number of poles	Kind of operation < >: Momentary position	Solder terminal		Products subject to the Electrical Appliances and Material Safety Act
		Type No.	Part No.	
1-pole	ON-OFF	TD115A-F	WD101181F	-
	ON-ON	TD115D-F	WD111181F	-
	ON-OFF-ON	TD115E-F	WD111281F	-
	ON-<ON>	TD115F-F	WD111381F	-
	<ON>-OFF-<ON>	TD115G-F	WD111481F	-
	ON-OFF-<ON>	TD115H-F	WD111581F	-
2-pole	ON-OFF	TD215K-F	WD121181F	-
	ON-ON	TD215N-F	WD131181F	-
	ON-OFF-ON	TD215P-F	WD131281F	-
	ON-<ON>	TD215R-F	WD131381F	-
	<ON>-OFF-<ON>	TD215S-F	WD131481F	-
	ON-OFF-<ON>	TD215T-F	WD131581F	-

Note: Of the standard installation accessories that come with the product, the front hex nut and lock washer are included.

## 2) Screw terminal

Number of poles	Kind of operation < >: Momentary position	Screw terminal		Products subject to the Electrical Appliances and Material Safety Act
		Type No.	Part No.	
1-pole	ON-OFF	TD115A-SF	WD102181F	Available
	ON-ON	TD115D-SF	WD112181F	Available
	ON-OFF-ON	TD115E-SF	WD112281F	Available
	ON-<ON>	TD115F-SF	WD112381F	Available
	<ON>-OFF-<ON>	TD115G-SF	WD112481F	Available
	ON-OFF-<ON>	TD115H-SF	WD112581F	Available
2-pole	ON-OFF	TD215K-SF	WD122181F	Available
	ON-ON	TD215N-SF	WD132181F	-
	ON-OFF-ON	TD215P-SF	WD132281F	-
	ON-<ON>	TD215R-SF	WD132381F	-
	<ON>-OFF-<ON>	TD215S-SF	WD132481F	-
	ON-OFF-<ON>	TD215T-SF	WD132581F	-

Note: Of the standard installation accessories that come with the product, the front hex nut and lock washer are included.

## ● Wire lead type

Number of poles	Kind of operation < >: Momentary position	Wire lead type き		Products subject to the Electrical Appliances and Material Safety Act
		Type No.	Part No.	
1-pole	ON-OFF	TC115A-F	WD101182F	Available
	ON-ON	TC115D-F	WD111182F	Available
	ON-OFF-ON	TC115E-F	WD111282F	Available
	ON-<ON>	TC115F-F	WD111382F	Available
	<ON>-OFF-<ON>	TC115G-F	WD111482F	Available
	ON-OFF-<ON>	TC115H-F	WD111582F	Available
2-pole	ON-OFF	TC215K-F	WD121182F	Available
	ON-ON	TC215N-F	WD131182F	-
	ON-OFF-ON	TC215P-F	WD131282F	-
	ON-<ON>	TC215R-F	WD131382F	-
	<ON>-OFF-<ON>	TC215S-F	WD131482F	-
	ON-OFF-<ON>	TC215T-F	WD131582F	-

Notes: 1. Of the standard installation accessories that come with the part, the front hex nut and lock washer are included.

2. 300 V vinyl wire (VSF, thick: 2 mm<sup>2</sup>, length: 200 mm) is used. Please inquire about type and different length of lead wire.

# T-15 Series Switches (WD1, WDR1, WDB1)

## Accessories

### 1) Installation accessories (Repair parts)

Product name	Standard installation accessories				Optional installation accessories
	Front hex nut (Nickel plated)	Back hex nut (Uni-chrome plated)	Keying washer	Lock washer	Front Knurl nut (Nickel plated)
Dimensions (Unit: mm)					
Part No.	AJ3081	AJ3082	AJ3083	AJ3084	AJ3080

Note: A selling unit of each accessory is 10 pieces.

### Using the different rubber caps

We recommend silicon rubber and EP rubber caps for the following applications.

#### 1) Silicon rubber type

- When it is necessary to differentiate by color.
- When using in applications that require resistance to heat and cold. Ambient temperature: -25 to +85°C (EP rubber type is 0 to +40°C.)
- When compactness is required.

#### 2) EP rubber type

When cost is the primary consideration.

### 2) Accessories (Option)

Product name	Indication plate (aluminum) <sup>(Note 3)</sup>		Rubber cap <sup>(Note 1, 2, 4, 5, 6)</sup>	
	ON-OFF	ON-ON	EP rubber type	Silicone rubber type
Dimensions (Unit: mm)				
Part No.	WD1901	WD1902	WD1911	WD1811*

Notes: 1. The asterisk "\*" in the part number WD1811\* for the silicon rubber type rubber cap is where the letter representing the color should be inserted.

(B: black; R: red; Z: grey; Y: yellow; G: green.)

2. EP rubber cap is available in black only.

3. Letters on the display panel are aluminum colored and the area surrounding the letters is black.

4. Indication plate and rubber cap are compatible with the T-15 series switch, T-10 series switch, and T-03/T-06 series switches (when plate thickness is 2.7 mm or less).

5. Applicable EP rubber type switches are only available in ON-OFF, ON-ON, ON <- ON>, and <ON>-OFF <- ON>. "< >": Momentary position

6. When using mid-point OFF type (ON-OFF-ON and ON-OFF-<ON>) at low temperatures (5°C and lower) please use the separately sold rubber cap (silicon rubber type) (WD1811\*). < > indicates rebound.

**ORDERING INFORMATION (PART NO.)**

**■ Rocker switches**

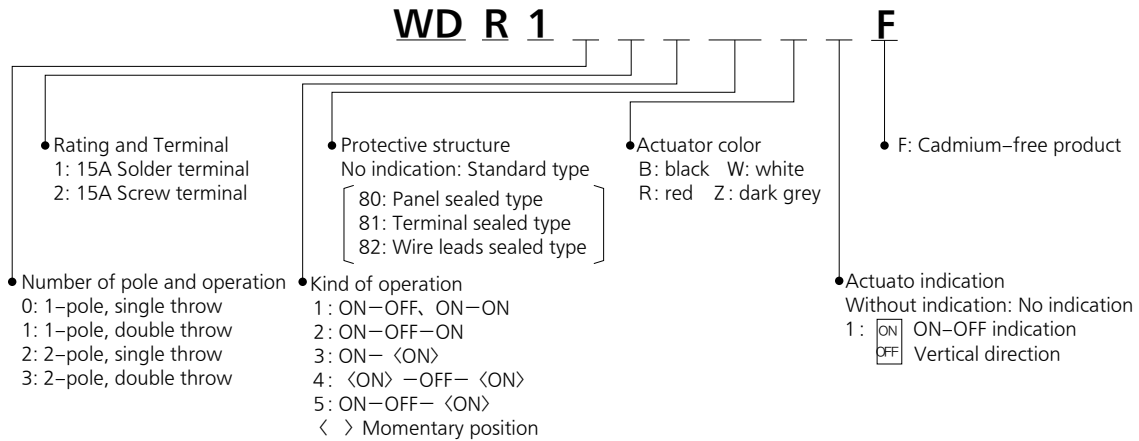

**TYPES**

**■ Rocker types**



● Standard type

1) Solder terminal, without indication on actuator

Number of poles	Kind of operation < >: Momentary position	Solder terminal		Products subject to the Electrical Appliances and Material Safety Act
		Type No.	Part No.	
1-pole	ON-OFF	TR115A-*F	WDR1011*F	-
	ON-ON	TR115D-*F	WDR1111*F	-
	ON-OFF-ON	TR115E-*F	WDR1112*F	-
	ON-<ON>	TR115F-*F	WDR1113*F	-
	<ON>-OFF-<ON>	TR115G-*F	WDR1114*F	-
	ON-OFF-<ON>	TR115H-*F	WDR1115*F	-
2-pole	ON-OFF	TR215K-*F	WDR1211*F	-
	ON-ON	TR215N-*F	WDR1311*F	-
	ON-OFF-ON	TR215P-*F	WDR1312*F	-
	ON-<ON>	TR215R-*F	WDR1313*F	-
	<ON>-OFF-<ON>	TR215S-*F	WDR1314*F	-
	ON-OFF-<ON>	TR215T-*F	WDR1315*F	-

Note: Please specify the actuator color by replacing the asterisk "\*" in the part number with appropriate letter. (B: black; W: white; R: red; Z: dark grey)

2) Screw terminal, without indication on actuator

Number of poles	Kind of operation < >: Momentary position	Screw terminal		Products subject to the Electrical Appliances and Material Safety Act
		Type No.	Part No.	
1-pole	ON-OFF	TR115A-S*F	WDR1021*F	Available
	ON-ON	TR115D-S*F	WDR1121*F	Available
	ON-OFF-ON	TR115E-S*F	WDR1122*F	Available
	ON-<ON>	TR115F-S*F	WDR1123*F	Available
	<ON>-OFF-<ON>	TR115G-S*F	WDR1124*F	Available
	ON-OFF-<ON>	TR115H-S*F	WDR1125*F	Available
2-pole	ON-OFF	TR215K-S*F	WDR1221*F	Available
	ON-ON	TR215N-S*F	WDR1321*F	-
	ON-OFF-ON	TR215P-S*F	WDR1322*F	-
	ON-<ON>	TR215R-S*F	WDR1323*F	-
	<ON>-OFF-<ON>	TR215S-S*F	WDR1324*F	-
	ON-OFF-<ON>	TR215T-S*F	WDR1325*F	-

Note: Please specify the actuator color by replacing the asterisk "\*" in the part number with appropriate letter. (B: black; W: white; R: red; Z: dark grey)



# T-15 Series Switches (WD1, WDR1, WDB1)

## 3) Solder terminal, with ON-OFF indication on actuator

Number of poles	Kind of operation	Solder terminal		Products subject to the Electrical Appliances and Material Safety Act
		Type No.	Part No.	
1-pole	ON-OFF	TR115A-*1F	WDR1011*1F	-
2-pole	ON-OFF	TR215K-*1F	WDR1211*1F	-

Note: Please specify the actuator color by replacing the asterisk "\*" in the part number with appropriate letter. (B: black; W: white; R: red; Z: dark grey)

## 4) Screw terminal, with ON-OFF indication on actuator

Number of poles	Kind of operation	Screw terminal		Products subject to the Electrical Appliances and Material Safety Act
		Type No.	Part No.	
1-pole	ON-OFF	TR115A-S*1F	WDR1021*1F	Available
2-pole	ON-OFF	TR215K-S*1F	WDR1221*1F	Available

Note: Please specify the actuator color by replacing the asterisk "\*" in the part number with appropriate letter. (B: black; W: white; R: red; Z: dark grey)

## ● Panel-sealed type

### 1) Solder terminal, without indication on actuator

Number of poles	Kind of operation < >: Momentary position	Solder terminal		Products subject to the Electrical Appliances and Material Safety Act
		Type No.	Part No.	
1-pole	ON-OFF	TRP115A-*F	WDR101180*F	-
	ON-ON	TRP115D-*F	WDR111180*F	-
	ON-OFF-ON	TRP115E-*F	WDR111280*F	-
	ON-<ON>	TRP115F-*F	WDR111380*F	-
	<ON>-OFF-<ON>	TRP115G-*F	WDR111480*F	-
	ON-OFF-<ON>	TRP115H-*F	WDR111580*F	-
2-pole	ON-OFF	TRP215K-*F	WDR121180*F	-
	ON-ON	TRP215N-*F	WDR131180*F	-
	ON-OFF-ON	TRP215P-*F	WDR131280*F	-
	ON-<ON>	TRP215R-*F	WDR131380*F	-
	<ON>-OFF-<ON>	TRP215S-*F	WDR131480*F	-
	ON-OFF-<ON>	TRP215T-*F	WDR131580*F	-

Note: Please specify the actuator color by replacing the asterisk "\*" in the part number with appropriate letter. (B: black; W: white; R: red; Z: dark grey)

### 2) Screw terminal, without indication on actuator

Number of poles	Kind of operation < >: Momentary position	Screw terminal		Products subject to the Electrical Appliances and Material Safety Act
		Type No.	Part No.	
1-pole	ON-OFF	TRP115A-S*F	WDR102180*F	Available
	ON-ON	TRP115D-S*F	WDR112180*F	Available
	ON-OFF-ON	TRP115E-S*F	WDR112280*F	Available
	ON-<ON>	TRP115F-S*F	WDR112380*F	Available
	<ON>-OFF-<ON>	TRP115G-S*F	WDR112480*F	Available
	ON-OFF-<ON>	TRP115H-S*F	WDR112580*F	Available
2-pole	ON-OFF	TRP215K-S*F	WDR122180*F	Available
	ON-ON	TRP215N-S*F	WDR132180*F	-
	ON-OFF-ON	TRP215P-S*F	WDR132280*F	-
	ON-<ON>	TRP215R-S*F	WDR132380*F	-
	<ON>-OFF-<ON>	TRP215S-S*F	WDR132480*F	-
	ON-OFF-<ON>	TRP215T-S*F	WDR132580*F	-

Note: Please specify the actuator color by replacing the asterisk "\*" in the part number with appropriate letter. (B: black; W: white; R: red; Z: dark grey)

### 3) Solder terminal, with ON-OFF indication on actuator

Number of poles	Kind of operation	Solder terminal		Products subject to the Electrical Appliances and Material Safety Act
		Type No.	Part No.	
1-pole	ON-OFF	TRP115A-*1F	WDR101180*1F	-
2-pole	ON-OFF	TRP215K-*1F	WDR121180*1F	-

Note: Please specify the actuator color by replacing the asterisk "\*" in the part number with appropriate letter. (B: black; W: white; R: red; Z: dark grey)

## 4) Screw terminal, with ON-OFF indication on actuator

Number of poles	Kind of operation	Screw terminal		Products subject to the Electrical Appliances and Material Safety Act
		Type No.	Part No.	
1-pole	ON-OFF	TRP115A-S*1F	WDR102180*1F	Available
2-pole	ON-OFF	TRP215K-S*1F	WDR122180*1F	Available

Note: Please specify the actuator color by replacing the asterisk "\*" in the part number with appropriate letter. (B: black; W: white; R: red; Z: dark grey)

## ● Terminal-sealed type

## 1) Solder terminal, without indication on actuator

Number of poles	Kind of operation < >: Momentary position	Solder terminal		Products subject to the Electrical Appliances and Material Safety Act
		Type No.	Part No.	
1-pole	ON-OFF	TRD115A-*F	WDR101181*F	-
	ON-ON	TRD115D-*F	WDR111181*F	-
	ON-OFF-ON	TRD115E-*F	WDR111281*F	-
	ON-<ON>	TRD115F-*F	WDR111381*F	-
	<ON>-OFF-<ON>	TRD115G-*F	WDR111481*F	-
	ON-OFF-<ON>	TRD115H-*F	WDR111581*F	-
2-pole	ON-OFF	TRD215K-*F	WDR121181*F	-
	ON-ON	TRD215N-*F	WDR131181*F	-
	ON-OFF-ON	TRD215P-*F	WDR131281*F	-
	ON-<ON>	TRD215R-*F	WDR131381*F	-
	<ON>-OFF-<ON>	TRD215S-*F	WDR131481*F	-
	ON-OFF-<ON>	TRD215T-*F	WDR131581*F	-

Note: Please specify the actuator color by replacing the asterisk "\*" in the part number with appropriate letter. (B: black; W: white; R: red; Z: dark grey)

## 2) Screw terminal, without indication on actuator

Number of poles	Kind of operation < >: Momentary position	Screw terminal		Products subject to the Electrical Appliances and Material Safety Act
		Type No.	Part No.	
1-pole	ON-OFF	TRD115A-S*F	WDR102181*F	Available
	ON-ON	TRD115D-S*F	WDR112181*F	Available
	ON-OFF-ON	TRD115E-S*F	WDR112281*F	Available
	ON-<ON>	TRD115F-S*F	WDR112381*F	Available
	<ON>-OFF-<ON>	TRD115G-S*F	WDR112481*F	Available
	ON-OFF-<ON>	TRD115H-S*F	WDR112581*F	Available
2-pole	ON-OFF	TRD215K-S*F	WDR122181*F	Available
	ON-ON	TRD215N-S*F	WDR132181*F	-
	ON-OFF-ON	TRD215P-S*F	WDR132281*F	-
	ON-<ON>	TRD215R-S*F	WDR132381*F	-
	<ON>-OFF-<ON>	TRD215S-S*F	WDR132481*F	-
	ON-OFF-<ON>	TRD215T-S*F	WDR132581*F	-

Note: Please specify the actuator color by replacing the asterisk "\*" in the part number with appropriate letter. (B: black; W: white; R: red; Z: dark grey)

## 3) Solder terminal, with ON-OFF indication on actuator

Number of poles	Kind of operation	Solder terminal		Products subject to the Electrical Appliances and Material Safety Act
		Type No.	Part No.	
1-pole	ON-OFF	TRD115A-*1F	WDR101181*1F	-
2-pole	ON-OFF	TRD215K-*1F	WDR121181*1F	-

Note: Please specify the actuator color by replacing the asterisk "\*" in the part number with appropriate letter. (B: black; W: white; R: red; Z: dark grey)

## 4) Screw terminal, with ON-OFF indication on actuator

Number of poles	Kind of operation	Screw terminal		Products subject to the Electrical Appliances and Material Safety Act
		Type No.	Part No.	
1-pole	ON-OFF	TRD115A-S*1F	WDR102181*1F	Available
2-pole	ON-OFF	TRD215K-S*1F	WDR122181*1F	Available

Note: Please specify the actuator color by replacing the asterisk "\*" in the part number with appropriate letter. (B: black; W: white; R: red; Z: dark grey)

# T-15 Series Switches (WD1, WDR1, WDB1)

## ● Wire lead sealed type

### 1) Without indication on actuator

Number of poles	Kind of operation < >: Momentary position	Wire lead type		Products subject to the Electrical Appliances and Material Safety Act
		Type No.	Part No.	
1-pole	ON-OFF	TRC115A-*F	WDR101182*F	Available
	ON-ON	TRC115D-*F	WDR111182*F	Available
	ON-OFF-ON	TRC115E-*F	WDR111282*F	Available
	ON-<ON>	TRC115F-*F	WDR111382*F	Available
	<ON>-OFF-<ON>	TRC115G-*F	WDR111482*F	Available
	ON-OFF-<ON>	TRC115H-*F	WDR111582*F	Available
2-pole	ON-OFF	TRC215K-*F	WDR121182*F	Available
	ON-ON	TRC215N-*F	WDR131182*F	-
	ON-OFF-ON	TRC215P-*F	WDR131282*F	-
	ON-<ON>	TRC215R-*F	WDR131382*F	-
	<ON>-OFF-<ON>	TRC215S-*F	WDR131482*F	-
	ON-OFF-<ON>	TRC215T-*F	WDR131582*F	-

Notes: 1. Please specify the actuator color by replacing the asterisk "\*" in the part number with appropriate letter. (B: black; W: white; R: red; Z: dark grey)  
 2. 300 V vinyl wire (VSF, thick: 2 mm<sup>2</sup>, length: 200 mm) is used. Please inquire about type and different length of lead wire.

### 2) With ON-OFF indication on actuator

Number of poles	Kind of operation	Wire lead type		Products subject to the Electrical Appliances and Material Safety Act
		Type No.	Part No.	
1-pole	ON-OFF	TRC115A-*1F	WDR101182*1F	Available
2-pole	ON-OFF	TRC215K-*1F	WDR121182*1F	Available

Notes: 1. Please specify the actuator color by replacing the asterisk "\*" in the part number with appropriate letter. (B: black; W: white; R: red; Z: dark grey)  
 2. 300 V vinyl wire (VSF, thick: 2 mm<sup>2</sup>, length: 200 mm) is used. Please inquire about type and different length of lead wire.

**ORDERING INFORMATION (PART NO.)**

**Push-button switches**

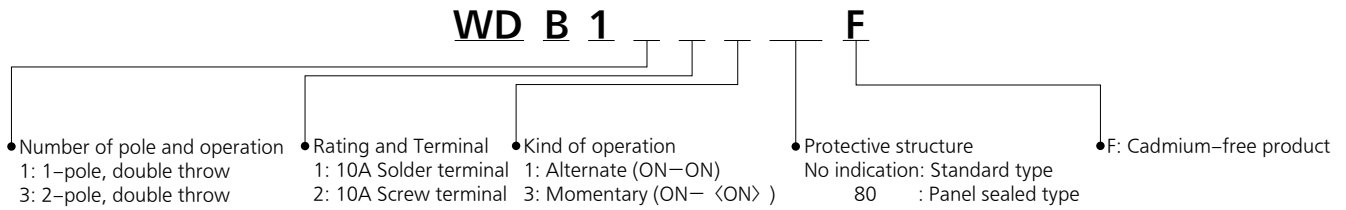

**TYPES**

**Push-button product types**



**Standard type**

**1) Solder terminal**

Number of poles	Kind of operation	Solder terminal		Products subject to the Electrical Appliances and Material Safety Act
		Type No.	Part No.	
1-pole	Momentary	TB110F-F	WDB1113F	-
	Alternate	TB115D-F	WDB1111F	-
2-pole	Momentary	TB210R-F	WDB1313F	-
	Alternate	TB215N-F	WDB1311F	-

**2) Screw terminal**

Number of poles	Kind of operation	Screw terminal		Products subject to the Electrical Appliances and Material Safety Act
		Type No.	Part No.	
1-pole	Momentary	TB110F-SF	WDB1123F	Available
	Alternate	TB115D-SF	WDB1121F	Available
2-pole	Momentary	TB210R-SF	WDB1323F	-
	Alternate	TB215N-SF	WDB1321F	-

Notes: 1. Please use switch body with a color cap (sold separately).  
 2. Standard installation accessories are included with the product.

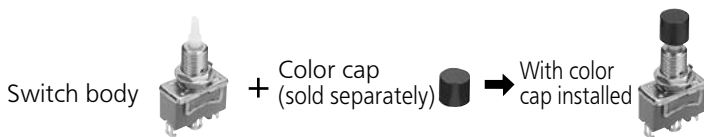

# T-15 Series Switches (WD1, WDR1, WDB1)

## ● Panel-sealed type

### 1) Solder terminal

Number of poles	Kind of operation	Solder terminal		Products subject to the Electrical Appliances and Material Safety Act
		Type No.	Part No.	
1-pole	Momentary	TBP110F-F	WDB111380F	-
	Alternate	TBP115D-F	WDB111180F	-
2-pole	Momentary	TBP210R-F	WDB131380F	-
	Alternate	TBP215N-F	WDB131180F	-

### 2) Screw terminal

Number of poles	Kind of operation	Screw terminal		Products subject to the Electrical Appliances and Material Safety Act
		Type No.	Part No.	
1-pole	Momentary	TBP110F-SF	WDB112380F	Available
	Alternate	TBP115D-SF	WDB112180F	Available
2-pole	Momentary	TBP210R-SF	WDB132380F	-
	Alternate	TBP215N-SF	WDB132180F	-

Notes: 1. Please use switch body with a color cap (sold separately).  
2. Standard installation accessories are included with the product.



## ■ Color cap for push-button (Option)

Product name	Color cap (sold separately)
Dimensions (Unit: mm)	
Part No.	WDB1821*

Note: Please specify the color cap color by replacing the asterisk "\*" in the part number with appropriate letter (B: black; W: white; R: red; Z: dark grey; H: light grey; Y: yellow; G: green; L: blue).

## ■ Installation accessories (Repair parts)

Product name	Standard installation accessories				Optional installation accessories
	Front hex nut (Nickel plated)	Back hex nut (Uni-chrome plated)	Keying washer	Lock washer	Front Knurl nut (Nickel plated)
Dimensions (Unit: mm)					
Part No.	AJ3081	AJ3082	AJ3083	AJ3084	AJ3080

Note: A selling unit of each accessory is 10 pieces.

**RATING**

**Contact rating**

1) Toggle type and Rocker type

Kind of load	AC rating	DC rating
Resistive load	15 A 250 V	0.5 A 250 V, 0.9 A 125 V, 15 A 30 V
Inductive load	15 A 250 V (Power factor: 0.6)	0.3 A 250 V (Time constant: 8 ms), 0.5 A 125 V (Time constant: 8 ms) 15 A 30 V (Time constant: 8 ms)

2) Push-button type (momentary)

Kind of load	AC rating	DC rating
Resistive load	10 A 250 V	0.4 A 250 V, 0.8 A 125 V, 8 A 30 V

3) Push-button type (alternate)

Kind of load	AC rating	DC rating
Resistive load	15 A 250 V	0.5 A 250 V, 0.9 A 125 V, 15 A 30 V

**Characteristics**

Item	Specifications		
	Toggle type	Rocker type	Push-button type
Shape of actuator			
Mechanical expected life	1-pole and 2-pole: Min. $10^5$ 3-pole and 4-pole: Min. $8.5 \times 10^4$	Min. $5 \times 10^4$ (20 cpm) ON-OFF, ON-ON, ON-OFF-ON, Min. $3 \times 10^4$ (20 cpm) ON-(ON), (ON)-OFF-(ON), ON-OFF-(ON)	Min. $3 \times 10^4$ (20 cpm)
Electrical expected life (10 cpm)	Standard and panel-sealed types: Min. $3 \times 10^4$ Terminal-sealed and wire leads types: Min. $1.5 \times 10^4$	Standard type: Min. $3 \times 10^4$ Panel-sealed, terminal-sealed and wire leads types: Min. $10^4$	Min. $10^4$
Dielectric strength	1500 Vrms for 1 min (at detection current: 10 mA)		
Insulation resistance	Min. 100 MΩ (at 500 V DC measured by insulation resistive meter)		
Contact resistance	Initial, Max. 10 mΩ (By voltage drop at 1 A, 2 to 4 V DC) Wire leads type only: Initial, Max. 30 mΩ (By voltage drop at the end of the lead wire at 1 A, 2 to 4 V DC)		
Actuator strength	112.7 N for 1 min (For operating direction)		
Vibration resistance	10 to 55 Hz at double amplitude of 1.5 mm (contact opening: Max. 1 ms)		
Terminal strength (static load)	24.5 N for 1 min		
Ambient temperature	-25 to +70°C (Not freezing below 0°C)		
Contact material	AgZnO alloy		

**DATA**

Electrical life, For toggle standard type

Tested condition: 250 V AC, Power factor: 0.6 and 10 cpm

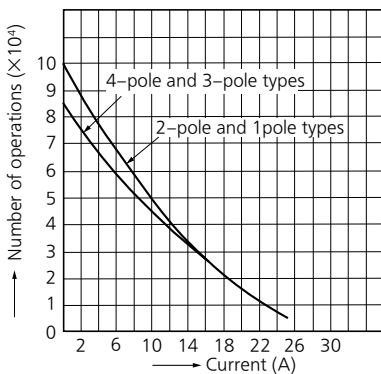

# T-15 Series Switches (WD1, WDR1, WDB1)

## DIMENSIONS

**CAD** The CAD data of the products with a "CAD" mark can be downloaded from our Website.

Unit: mm

### Toggle Type

#### CAD

- Standard type
- 1) Solder terminal

#### External dimensions

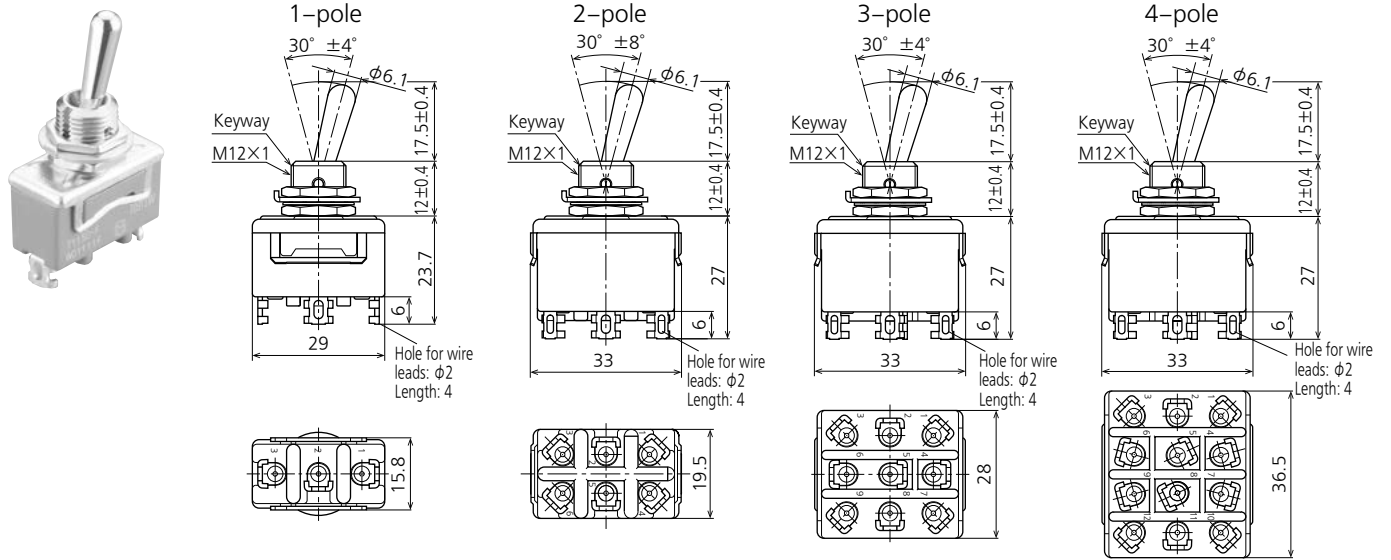

Note) ON-OFF type does not have terminal No. 2, 5, 8 and 11.

General tolerance:  $\pm 0.5$

- 2) Screw terminal (M3.5)

#### External dimensions

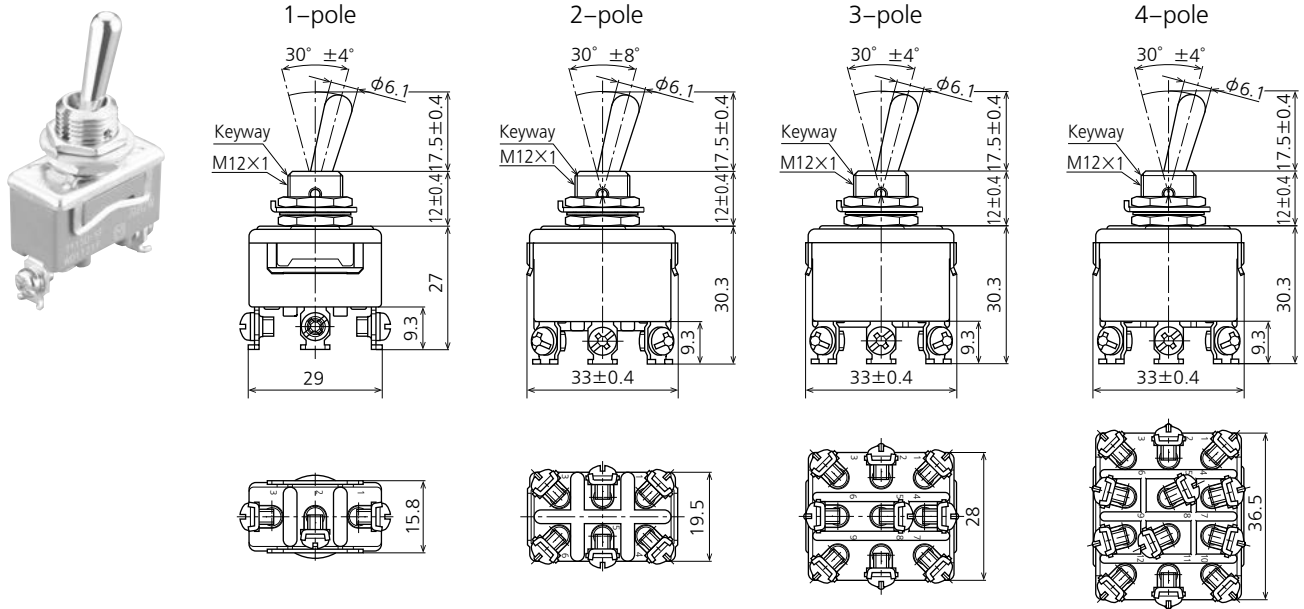

Note) ON-OFF type does not have terminal No. 2, 5, 8 and 11.

General tolerance:  $\pm 0.5$

3) .250 Quick-connect terminal

External dimensions

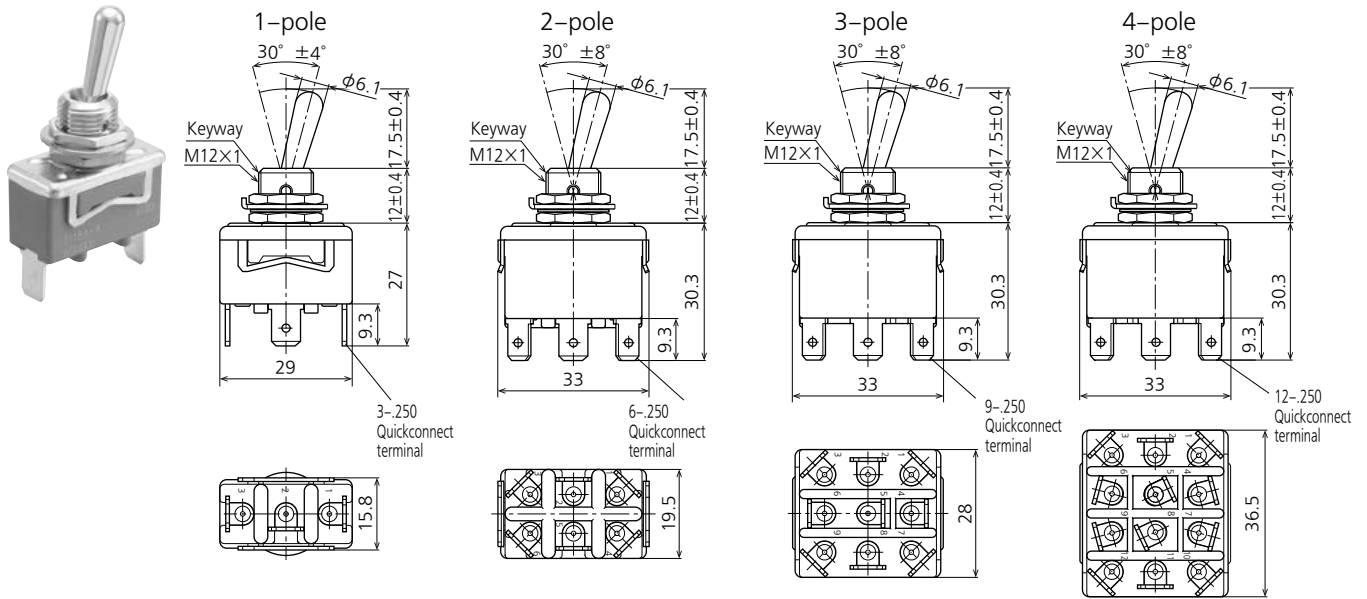

Notes) 1: ON-OFF type does not have terminal No. 2, 5, 8 and 11  
 2: There is no through-hole on .250 Quick-connect terminals.

General tolerance:  $\pm 0.5$

● Panel-sealed type

1) Solder terminal

External dimensions

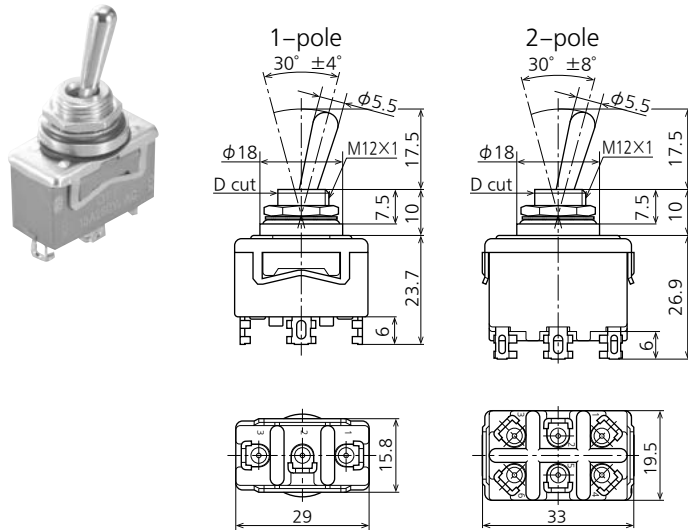

General tolerance:  $\pm 0.5$

Note) ON-OFF type does not have terminal No. 2 and 5.

2) Screw terminal (M3.5)

External dimensions

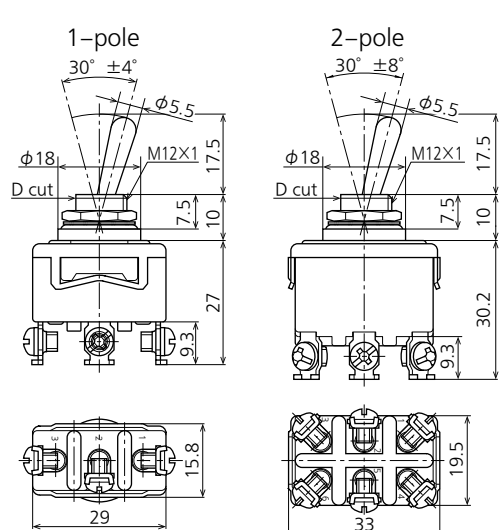

General tolerance:  $\pm 0.5$



# T-15 Series Switches (WD1, WDR1, WDB1)

## Terminal-sealed type

### 1) Solder terminal



External dimensions

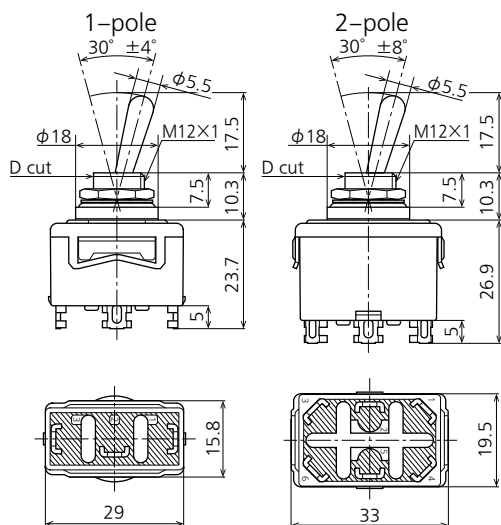

General tolerance:  $\pm 0.5$

Note) ON-OFF type does not have terminal No. 2 and 5.

### 2) Screw terminal (M3.5)

External dimensions

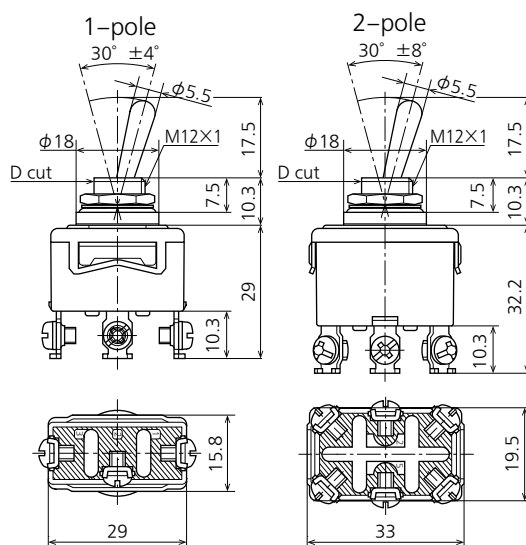

General tolerance:  $\pm 0.5$

## Wire leads type

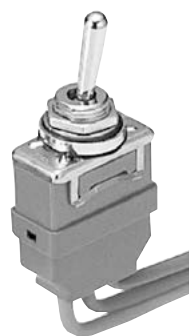

External dimensions

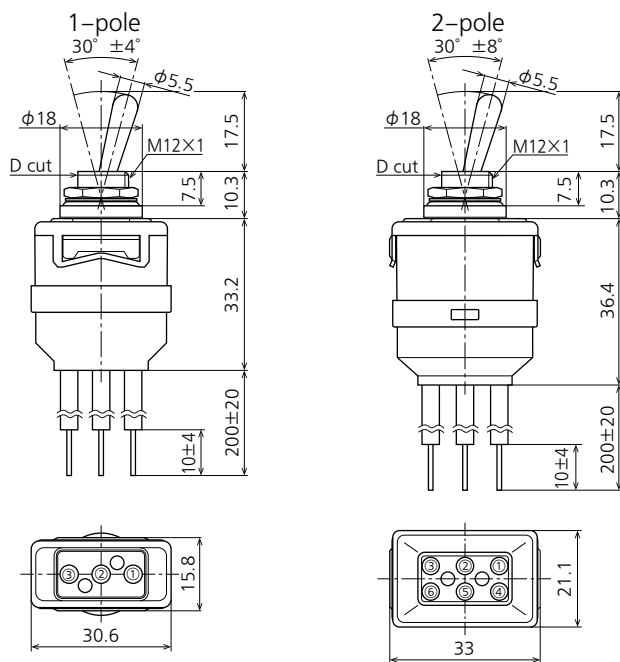

General tolerance:  $\pm 0.5$

Note) 1: ON-OFF type does not have wire lead No. 2 and 5.  
2: 300 V vinyl wire (VSF, thick: 2 mm<sup>2</sup>, length: 200 mm) is used.

Color of wire leads

No.	Color
1	Brown
2	Red
3	Orange
4	Yellow
5	Green
6	Blue

■ **Rocker Type**

**CAD**

● **Standard type**

1) Solder terminal

2) Screw terminal (M3.5)

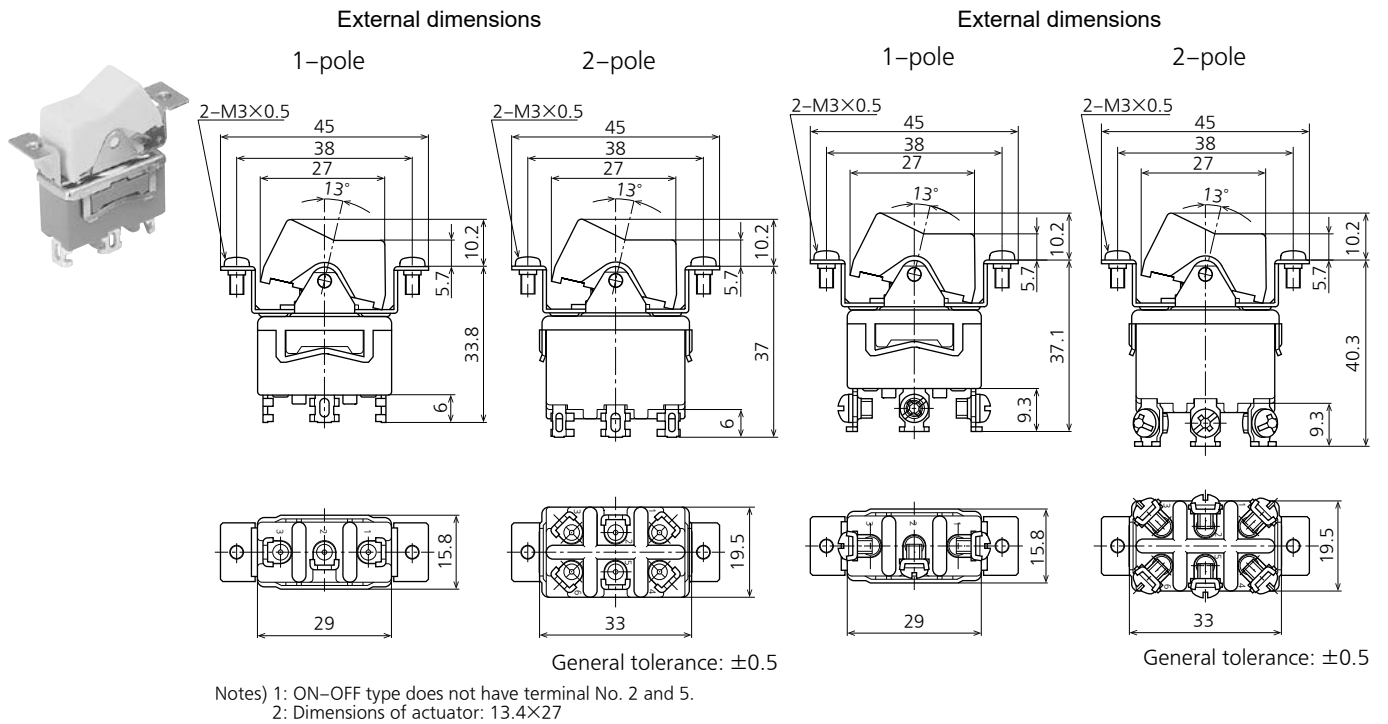

● **Panel-sealed type**

1) Solder terminal

2) Screw terminal (M3.5)

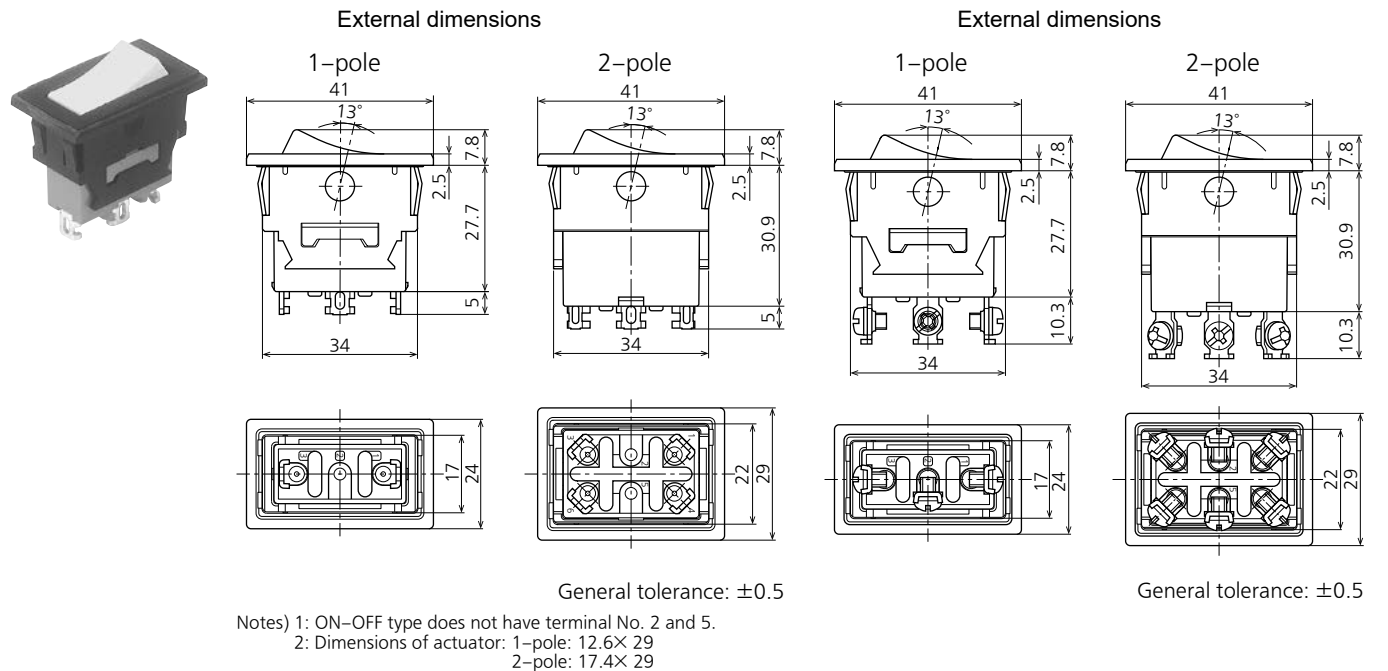

# T-15 Series Switches (WD1, WDR1, WDB1)

## ● Terminal-sealed type

### 1) Solder terminal

#### External dimensions

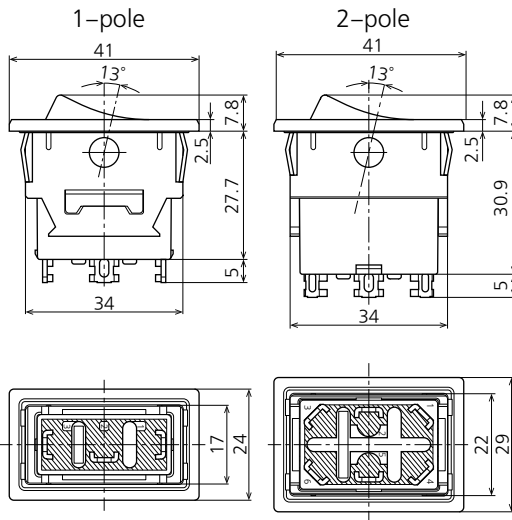

General tolerance:  $\pm 0.5$

### 2) Screw terminal (M3.5)

#### External dimensions

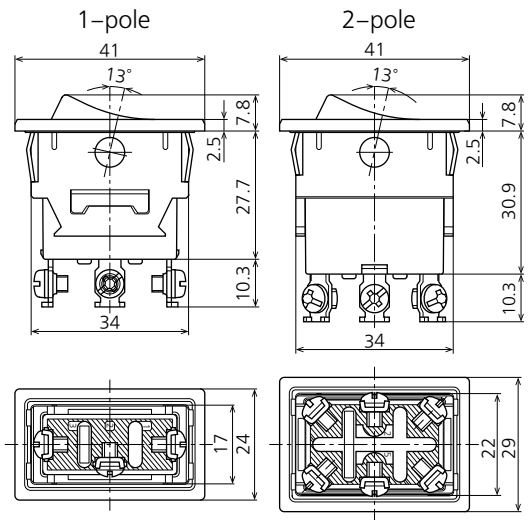

General tolerance:  $\pm 0.5$

Notes) 1: ON-OFF type does not have terminal No. 2 and 5.  
2: Dimensions of actuator: 1-pole: 12.6×29  
2-pole: 17.4×29

## ● Wire leads type

#### External dimensions

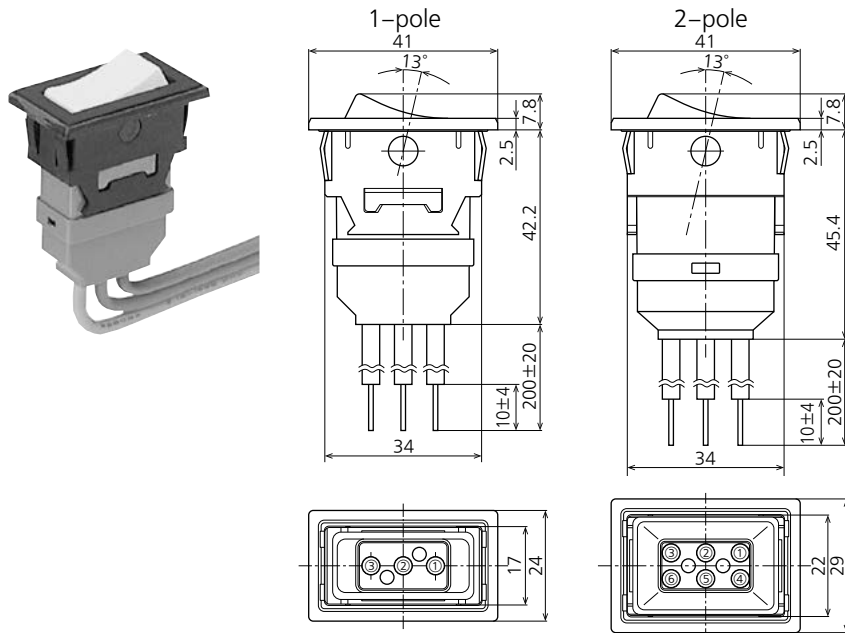

General tolerance:  $\pm 0.5$

Notes) 1: ON-OFF type does not have terminal No. 2 and 5.  
2: Dimensions of actuator: 1-pole: 12.6×29, 2-pole: 17.4×29  
3: 300 V vinyl wire (VSF, thick: 2 mm<sup>2</sup>, length: 200 mm) is used.

#### Color of wire leads

No.	Color
1	Brown
2	Red
3	Orange
4	Yellow
5	Green
6	Blue

■ Push-button Type

CAD

● Standard type

• Solder terminal, Momentary

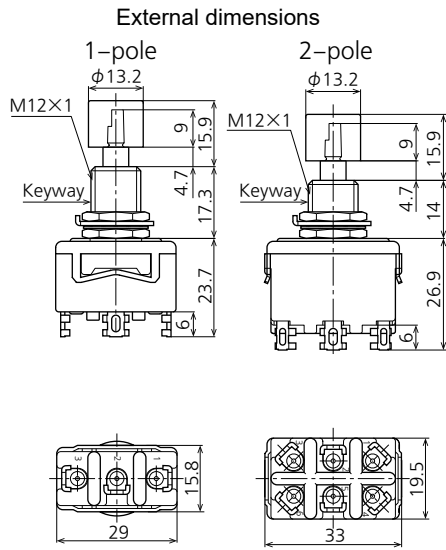

General tolerance:  $\pm 0.5$

• Solder terminal, Alternate

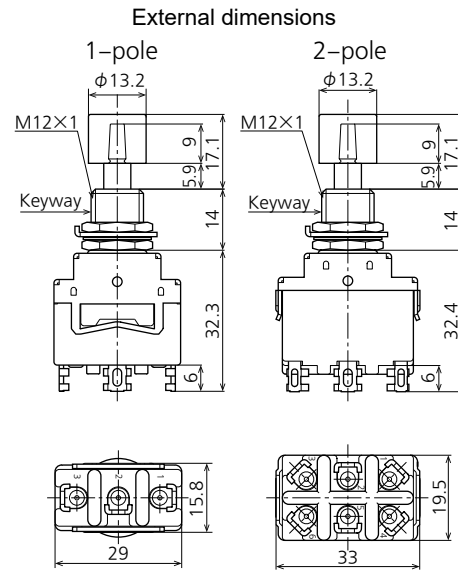

General tolerance:  $\pm 0.5$

• Screw terminal (M3.5)

Both momentary and alternate types only differ in the left solder terminal type and the terminal type.

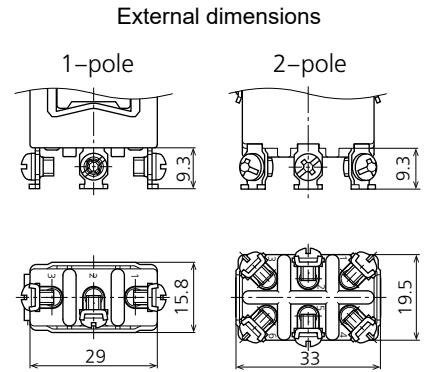

General tolerance:  $\pm 0.5$

● Panel-sealed type

• Solder terminal, Momentary

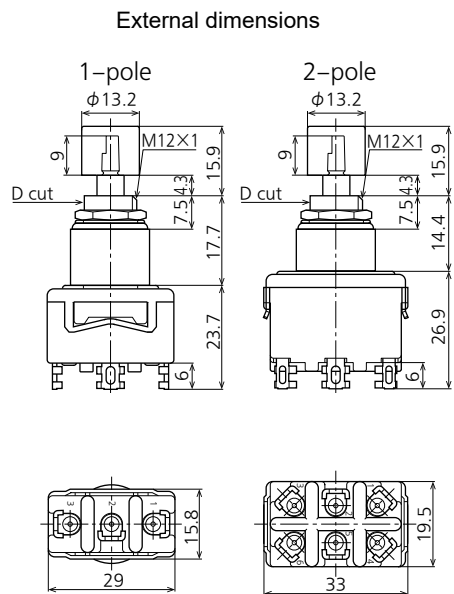

General tolerance:  $\pm 0.5$

• Solder terminal, Alternate

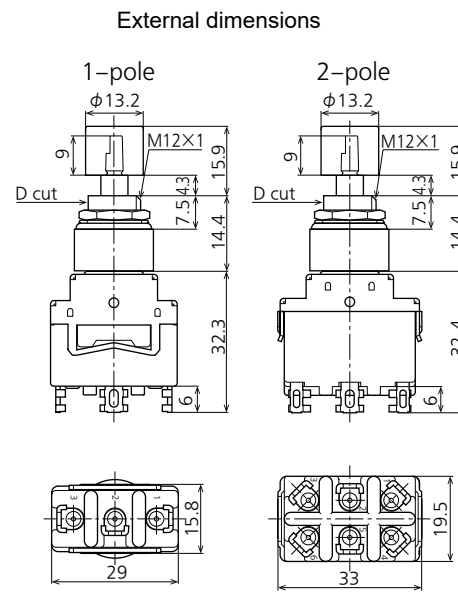

General tolerance:  $\pm 0.5$

• Screw terminal (M3.5)

Both momentary and alternate types only differ in the left solder terminal type and the terminal type.

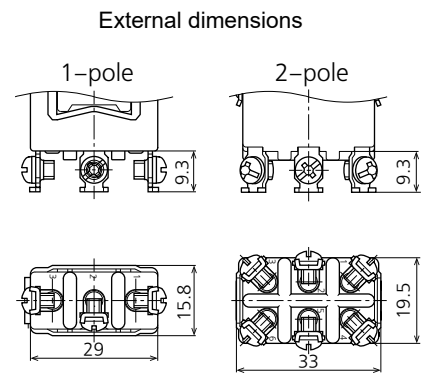

General tolerance:  $\pm 0.5$

# T-15 Series Switches (WD1, WDR1, WDB1)

## MOUNTING DIMENSIONS

### Toggle type

Type	Standard type		
Panel cutout (Unit: mm)			
Panel thickness	Max. 4.6 mm	Max. 5.6 mm (without keying washer)	Max. 5.6 mm (without keying washer)

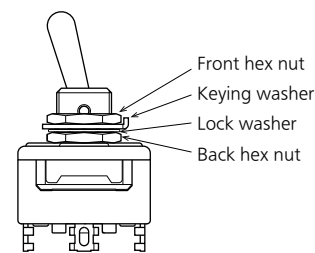

Type	Panel-sealed, Terminal-sealed and Wire leads types	
Panel cutout (Unit: mm)		
Panel thickness	Max. 4 mm	Max. 4 mm (without keying washer)

Note: For panel installations of standard type, be use to use the back hex nut.

### Rocker type

Type	Standard type	Panel-sealed, Terminal-sealed and Wire leads types	
Panel cutout (Unit: mm)		1-pole 	2-pole 
Panel thickness	Max. 4.5 mm	1.2 to 3.2 mm	

### Push-button Type

Type	Standard type			Panel-sealed type	
Panel cutout (Unit: mm)					
Panel thickness	Momentary, 1-pole: Max. 10 mm Momentary, 2-pole: Max. 6.5 mm Alternate: Max. 6.5 mm	Momentary, 1-pole: Max. 10 mm Momentary, 2-pole: Max. 7.5 mm Alternate: Max. 7.5 mm (without keying washer)	Momentary, 1-pole: Max. 11 mm Momentary, 2-pole: Max. 7.5 mm Alternate: Max. 7.5 mm (without keying washer)	Max. 4 mm	Max. 4 mm (without keying washer)

Note: For panel installations of standard type, be use to use the back hex nut.

**TERMINAL CIRCUIT DIAGRAM**

**Toggle type and Rocker type**

Number of pole				1-pole	2-pole	3-pole	4-pole	
Toggle type				Available	Available	Available*3	Available*3	
Rocker type				Available	Available	-	-	
Terminal arrangement (As seen from terminal side)								
Actuator position and contact terminal number	Actuator shape	Toggle type	Rocker type					
	ON-OFF			1-3	1-3, 4-6	1-3, 4-6, 7-9	1-3, 4-6, 7-9, 10-12	
		-	-	-	-	-	-	
				-	-	-	-	
	ON-ON ON<ON> *1			2-3	2-3, 5-6	2-3, 5-6, 8-9	2-3, 5-6, 8-9, 11-12	
		-	-	-	-	-	-	
				1-2	1-2, 4-5	1-2, 4-5, 7-8	1-2, 4-5, 7-8, 10-11	
	ON-OFF-ON <ON>-OFF-<ON> ON-OFF-<ON> *1			2-3	2-3, 5-6	2-3, 5-6, 8-9	2-3, 5-6, 8-9, 11-12	
				-	-	-	-	
				1-2	1-2, 4-5	1-2, 4-5, 7-8	1-2, 4-5, 7-8, 10-11	
	Remarks				ON-OFF type does not have a terminal No. 2.	ON-OFF type does not have terminal No. 2 and 5.	ON-OFF type does not have terminal No. 2, 5 and 8.	ON-OFF type does not have terminal No. 2, 5, 8 and 11.

Notes: \*1. For ON-<ON>, ON-OFF-<ON> type of toggle, if the lever turns to the keyway side, it takes momentary position.

\*2. For the rocker type, if the actuator turns to the left side in view of the side where a part number is marked, it takes momentary position.

\*3. Only standard type

**Push-button Type**

Number of pole		1-pole	2-pole
Terminal arrangement (As seen from terminal side)			
Push-button position and contact terminal number		2-3	2-3, 5-6
	Operated 	1-2	1-2, 4-5

**GUIDELINES FOR USAGE**

**■ Dustproof, waterproof, anticorrosive gas, and oil-proof designs**

The panel-sealed type/terminal-sealed type/wire lead type switch has a protection level of IP67 or IP64 on the outer side of the mounting panel and a level of IP40, IP60, or IP67 on the inner side of the panel. For actual application, note the following points:

- 1) Avoid immersion in water or oil during installation.
- 2) Avoid immersion in water or oil during operation.
- 3) Oils or gases impose varying degrees of impact on the switch's sealing performance depending on type or quantity.
- 4) While the switch has a immersion and dust-protected design, its sealing performance or operability may be adversely affected in an environment where in the switch's movable parts can be contaminated with dust, oil, or other foreign objects. For the toggle type, use of a rubber cap is recommended.
- 5) The standard toggle switch, when used with a rubber cap, provides a protection level of IP54. It should be used in an environment where it will not be subject to frequent water splashes.
- 6) As the sealing performance of the rocker type switch is affected by the panel processing accuracy or mounted panel thickness, check the switch under actual loading conditions. (While water or dust will not enter the switch's internal structure, it may enter the panel.)
- 7) Do not operate the rocker type switch when water accumulates in the actuator.

**■ Snap switch water resistance performance**

	Panel front			Panel interior		
	Toggle type	Rocker type	Push-button type	Toggle type	Rocker type	Push-button type
Standard type + Rubber cap	IP54	—	—	IP40	—	—
Panel-sealed type	IP67	IP64	IP67	IP40	IP40	IP40
Terminal-sealed type	IP67	IP64	—	IP60	IP60	—
Wire leads type	IP67	IP64	—	IP67	IP67	—

**■ Installation**

- 1) For the toggle and push-button type
  - a. When installing the standard type switch, be sure to use a hex nut.
  - b. For the panel-sealed, terminal-sealed and wire lead types, use a lock washer on the front side of the panel, and an O-ring on the back side of it.
  - c. Do not install the switch by holding and tightening it by hand.
- 2) For the rocker type
  - a. In case the panel-sealed, terminal-sealed or wire leads types are used in the condition where the water splash on, please in the case of vertical installation, please install the switches tilt more than 25° or in the case of horizontal installation, please install the switches tilt more than 50°. (90° recommended)

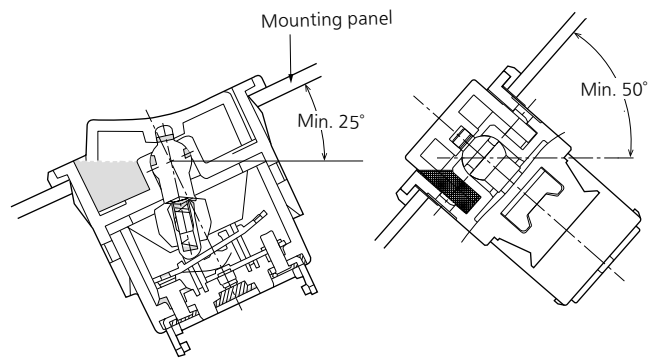

(Vertical installation)

(Horizontal installation)

- b. In case water inside the switch case may freeze, please install the switch vertically to avoid the water remain inside the switch.
- 3) Rubber cap installation
  - a. The washer should be used on the back side of the panel.

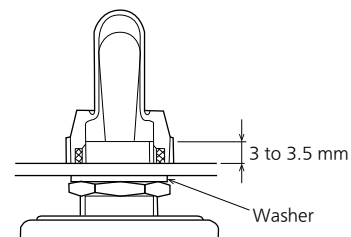

- b. Enough screw pitch should be obtained being adjusted within 3 to 3.5mm.
  - c. After first installing the rubber cap, please tighten to 1.96 Nm or less with a hexagonal nut.
  - d. The mounting hole in the panel should preferably be provided with an anti-rotation projection.

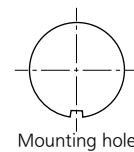

- e. If the rubber cap is installed over the hex nut, the waterproof performance will be impaired although the dustproof performance will not be affected.

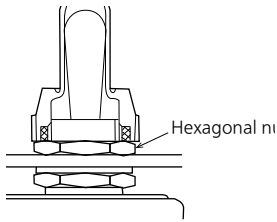

### ■ Soldering

Perform soldering in less than 3 seconds with maximum 350°C iron. Care should be taken not to apply force to the terminals during soldering. We recommend a soldering iron with temperature adjustment in order to prevent poor quality soldering.

Please consult us if you intend to use a soldering iron of 60 W or higher.

### ■ Load type and ratings

- 1) When the switch is loaded with a lamp, motor or capacitive load, a surge current higher than the stationary current passes through the switch contacts. Measure the surge with the actual load and, if needed, take necessary action so that the surge will not exceed the switch's rated current.
- 2) When the switch is loaded with an inductive load (relay, solenoid, buzzer, etc.), a contact failure may result from arc discharge caused by a counterelectromotive force. It is advisable that you use an adequate anti-spark circuit across the switch contacts.

### ■ Regarding Electrical Appliances and Material Safety Act

#### 1) Target products

For terminal shapes that are screw terminal type and that have wire leads, the models whose switch operation type is SPST, SPDT and DPST are targeted as "specified electrical appliances".

Regarding some of the target Panasonic T-15 Series Switches, they have been inspected for conformity by a third-party accreditation organization and satisfy the standards. However, in the conformance testing, these models are restricted for use as embedded components and cannot be used for other applications such as household products.

#### 2) Non-targeted products

In the Electrical Appliances and Material Safety Act, switches of "special construction for embedding in devices" are non-targeted special electrical appliances and are not under obligation to undergo conformance inspection, but they must satisfy technical standards. The conditions for not being targeted for the Electrical Appliances and Material Safety Act are that 1) they must not be SPST, SPDT and DPST types and 2) they must have solder terminals, FASTON terminals or PCB terminals, however, because non-targeted products are also switches for embedding into devices, they cannot be used for other applications such as household products.

### ■ Others

- 1) Do not apply an excessive static load exceeding 112.7 N perpendicular to the direction of operation.
- 2) Operate the switch actuator by hand.
- 3) Take care not to drop the product as it may impair performance.



## REFERENCE

### ■ Dust-protected type

This type of construction prevents dust that is large enough to have an effect on operation from getting inside the unit. This construction is stipulated by protective classes against solid matter in the IEC standards (IEC60529).

The talcum powder used shall be able to pass through a squaremeshed sieve the nominal wire diameter of 75 µm. The amount of talcum powder to be used is 2 kg per cubic metre of the test chamber volume. The duration of the test is 8 hours. No damage observed after the test.

### ■ Immersion-protected type

This type of construction prevents any harmful effects even after the device is left underwater at a depth of 1 m for 30 minutes. This construction is stipulated by protective classes against water in the IEC standards (IEC60529).

### ■ IEC's IP Codes

The IEC (International Electrotechnical Commission) has defined the IP characteristic code that represents the levels of protection described in IEC standard (IEC60529).

The two numbers that follow the IP code (the characteristics numbers) indicate the suitability of this protection for all environmental conditions.

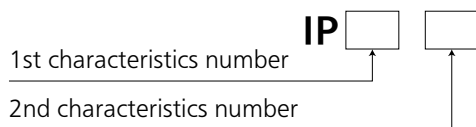

### ● Level of protection indicated by the 1st Characteristics number

1st Characteristics number	Protection level (IEC60529/Solid matter)
0	No protection
1	Protected against solid matter larger than 50 mm
2	Protected against solid matter larger than 12 mm
3	Protected against solid matter larger than 2.5 mm
4	Protected against solid matter larger than 1.0 mm
5	Dust-protected type Prevents dust that is large enough to have an effect on operation from getting inside the unit
6	Dust-resistant type Prevents dust from getting inside the unit

### ● Level of protection indicated by the 2nd Characteristics number

JIS C0920	2nd Characteristics number	Protection level (IEC60529/Liquid matter)
	0	No protection
Droplet-protected type I	1	Protected against water droplets that fall perpendicular to the unit
Droplet-protected type II	2	Protected against water droplets that fall from within 15° of perpendicular to the unit
Rain-protected type	3	Protected against water droplets that fall from within 60° of perpendicular to the unit
Splash-protected type	4	Protected against water that splashes on the unit from any direction
Spray-protected type	5	Free from adverse effects even if sprayed directly with water from any direction
Water-resistant type	6	Protected against water sprayed directly on the unit from any direction
Immersion-protected type	7	Water does not get inside of the unit when submerged in water according to the specified conditions
Underwater type	8	Unit can be used underwater

Note: Details of test conditions are the same as JIS C 0920. Please refer to them.

Please refer to **"the latest product specifications"** when designing your product.

•Requests to customers:

<https://industrial.panasonic.com/ac/e/salespolicies/>

## TECHNICAL TERMINOLOGY

### ■ Rated values

Values indicating the characteristics and performance guarantee standards of the switches. The rated current and rated voltage, for instance, assume specific conditions.

### ■ Electrical life

The service life when the rated load is connected to the contact and switching operations are performed.

### ■ Mechanical life

The service life when operated at a preset operating frequency without passing electricity through the contacts.

### ■ Dielectric strength

Threshold limit value that a high voltage can be applied to a predetermined measuring location for one minute without causing damage to the insulation.

### ■ Insulation resistance

This is the resistance value at the same place the dielectric strength is measured.

### ■ Contact resistance

This indicates the electrical resistance at the contact part. Generally, this resistance includes the conductor resistance of the spring and terminal portions.

### ■ Vibration resistance

Vibration range where a closed contact does not open for longer than a specified time due to vibrations during use of the snapaction switches.

### ■ Shock resistance

Max. shock value where a closed contact does not open for longer than a specified time due to shocks during use of the switches.

### ■ Allowable switching frequency

This is the maximum switching frequency required to reach the end of mechanical life (or electrical life).

### ■ Temperature rise value

This is the maximum temperature rise value that heats the terminal portion when the rated current is flowing through the contacts.

### ■ Actuator strength

When applying a static load for a certain period on the actuator in the operation direction, this is the maximum load it can withstand before the switch loses functionality.

### ■ Terminal strength

When applying a static load for a certain period (in all directions if not stipulated) on a terminal, this is the maximum load it can withstand before the terminal loses functionality (except when the terminal is deformed).

## TYPES OF LOAD

### ■ Resistance load

Resistance load is a power factor of 1 ( $\cos\phi = 1$ ) where the load is only for the resistance portion. The displayed switch rating indicates the current capacity when using AC current.

### ■ DC load

Differing from AC, since the direction of current is fixed for DC, the continuous arc time lengthens when the same voltage is applied.

### ■ Incandescent lamp load

Since an inrush current of 10 to 15 times the rated current flows for an instant when the switch is turned on for the lamp, adhesion of the contacts may occur. Therefore, please take into consideration this transient current when selecting a switch.

### ■ Induction load

Since arc generation due to reverse voltage can cause contact failure to occur when there is an induction load (in relays, solenoids and buzzers, etc.), we recommend you insert a suitable spark quenching circuit (see figure below).

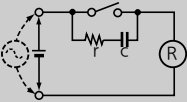
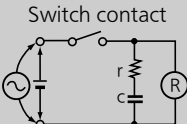
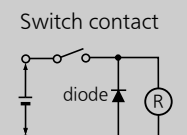
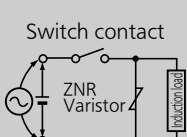
Circuit example	Notes
	(1) $r =$ more than $10\ \Omega$ (2) In an AC circuit, impedance of R is to be slightly smaller than impedance of r and c.
	Can be used for both AC and DC circuits. $r = R$ $C: 0.1\ \mu F$
	For DC circuits only.
	Can be used for both AC and DC circuits.

### ■ Motor load

Contacts may adhere due to the starting current at the start of motor operation which is three to eight times the steady-state current. Although it differs depending on the motor, since a current flows that is several times that of the nominal current, please select a switch taking into consideration the values in the table below. To make the motor rotate in reverse, use an ON-OFF-ON switch and take measures to prevent a multiplier current (starting current + reverse current) from flowing.

Motor type	Type	Starting current
Three-phase induction motor	Squirrel-cage	Approx. 5 to 8 times current listed on nameplate
Single-phase induction motor	Split-phase-start	Approx. 6 times current listed on nameplate
	Capacitor-start	Approx. 4 to 5 times current listed on nameplate
	Repulsion-start	Approx. 3 times current listed on nameplate

A current that is approximately two times that of the starting current will flow when reverse rotation is caused during operation. Also, when using for a load that will cause transient phenomena such as when operating the motor in reverse rotation or switching the poles, an arc short (circuit short) may occur due to the time lag between poles when switching. Please be careful.

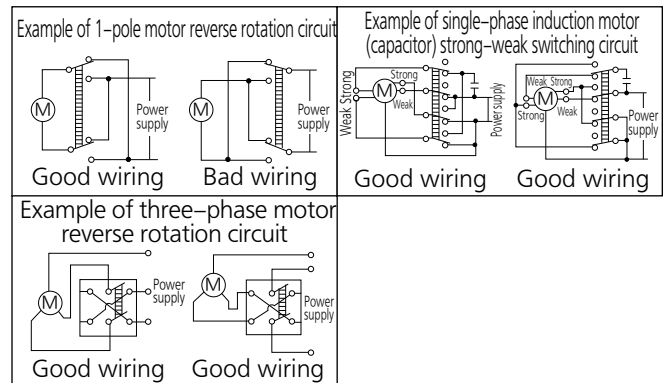

### ■ Capacitor load

In the case of mercury lamps, florescent lamps and the capacitor loads of capacitor circuits, since an extremely large inrush current flows when the switch is turned on, please measure that transient value with the actual load and then either use the product keeping within the range of the rated current or after verifying the actual load.

## CAUTIONS FOR USE

### Environment of use

- Please consult us when using under the following conditions:
  - Environments where hydrogen sulfide or other corrosive gases are present.
  - Environments where gasoline, thinner or other flammable, explosive gases are present.
  - Dusty environments (for non-seal type snap action switches).
  - Use in environments not in the prescribed temperature or humidity range.
  - Places with low air pressure.
- Unless specified the product will not be constructed to withstand water, oil or explosions. Please inquire if you intend to use the product in special applications.

### Usage, storage, and transport conditions

- During usage, storage, or transportation, avoid locations subject to direct sunlight and maintain normal temperature, humidity, and pressure conditions.
- The allowable specifications for environments suitable for usage, storage, and transportation are given below.
  - Temperature: The allowable temperature range differs for each switch, so refer to the switch's individual specifications.
  - Humidity: 5 to 85% R.H.
  - Pressure: 86 to 106 kPa  
The humidity range varies with the temperature. Use within the range indicated in the graph below.  
(The allowable temperature depends on the switch.)

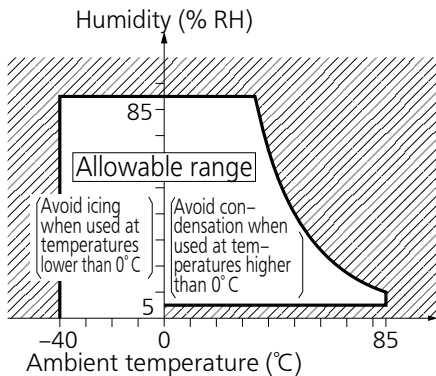

- Condensation will occur inside the switch if there is a sudden change in ambient temperature when used in an atmosphere of high temperature and high humidity. This is particularly likely to happen when being transported by ship, so please be careful of the atmosphere when shipping. Condensation is the phenomenon whereby steam condenses to cause water droplets that adhere to the switch when an atmosphere of high temperature and humidity rapidly changes from a high to low temperature or when the switch is quickly moved from a low humidity location to one of high temperature and humidity. Please be careful because condensation can cause adverse conditions such as deterioration of insulation, coil cutoff, and rust.
- Condensation or other moisture may freeze on the switch when the temperatures is lower than 0°C. This causes problems such as sticking of movable parts or operational time lags.
- The plastic becomes brittle if the switch is exposed to a low temperature, low humidity environment for long periods of time.
- Storage for extended periods of time (including transportation periods) at high temperatures or high humidity levels or in atmospheres with organic gases or sulfide gases may cause a sulfide film or oxide film to form on the surfaces of the contacts and/or it may interfere with the functions. Check out the atmosphere in which the units are to be stored and transported.
- In terms of the packing format used, make every effort to keep the effects of moisture, organic gases and sulfide gases to the absolute minimum.

### Wiring

- When using a P/C board terminal switch as soldering terminals, use thin lead wires and be sure to wind them on the terminals before soldering.
- Caution when soldering  
Perform soldering quickly in accordance with the specified conditions. Be careful not to let flux flow into the product. When no instruction is specified, use a soldering iron with a tip temperature of 350 C or lower and complete soldering within five seconds. Do not pull on the lead wires immediately after soldering. Wait some time before verifying.

### Others

- Failure modes of switches include short-circuiting, opencircuiting and temperature rises. If this switch is to be used in equipment where safety is a prime consideration, examine the possible effects of these failures on the equipment concerned, and ensure safety by providing protection circuits or protection devices. In terms of the systems involved, make provision for redundancy in the design and take steps to achieve safety design.
- The ambient operating temperature (and humidity) range quoted is the range in which the switch can be operated on a continuous basis: it does not mean that using the switch within the rating guarantees the durability performance and environment withstanding performance of the switch. For details on the performance guarantee, check the specifications of each product concerned.
- Even if 2-pole, 3-pole or 4-pole switches are used as singlepole switches in order to increase contact reliability, please keep the maximum current no higher than the rated value.
- If there is the possibility of a short between poles, please use an in-phase circuit as shown below or provide a spare pole.

#### Bad example

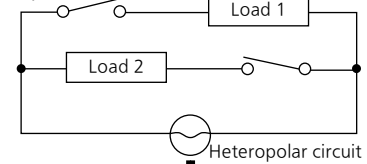

#### Good example①

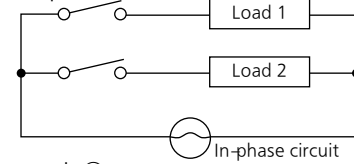

#### Good example②

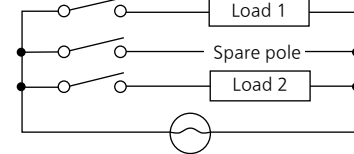

- Be careful not to drop the product as this may cause loss of functionality.
- Do not apply an unreasonable vertical force against the direction of operation of the product.
- Use your hand to operate the actuator.  
(Operation using a tool such as a screwdriver or hammer can cause breakdown.)

---

**Panasonic**  
INDUSTRY

**Panasonic Industry Co., Ltd.**

Electromechanical Control Business Division  
■1006, Oaza Kadoma, Kadoma-shi, Osaka 571-8506, Japan  
[industrial.panasonic.com/ac/e/](http://industrial.panasonic.com/ac/e/)

## X-ON Electronics

Largest Supplier of Electrical and Electronic Components

*Click to view similar products for [Toggle Switches](#) category:*

*Click to view products by [Panasonic](#) manufacturer:*

Other Similar products are found below :

[8928K478](#) [8951K2998](#) [8951K3310](#) [8956K1283](#) [8956K1285](#) [8956K1286](#) [8956K1287](#) [8961K155](#) [8A1-C-222](#) [020017-13](#) [0090-0001](#) [0121-0015](#) [CS115W](#) [CS120W](#) [CS215I](#) [CS8275](#) [637H/25](#) [7101SPDV30BE](#) [7103SDV30BE](#) [7105D](#) [7108P3YAV2BE](#) [71YY50282](#) [7209SY9AQE](#) [7209SYCBE](#) [7300K36](#) [7301SS24484](#) [7303KZQE](#) [7306K36](#) [7503K21](#) [7565K6](#) [7595K6](#) [7660K12](#) [7704K3](#) [8391K108](#) [8825K5](#) [8835K3](#) [8858K44](#) [8E4011](#) [1202W](#) [A201SCWZB04](#) [A207SYCB04](#) [A208J61ZQ0004](#) [A221T1TCQ](#) [A323S1CWZQ](#) [1201W](#) [1203W](#) [12156AX408](#) [1221W](#) [12147AGKX679](#) [1222W](#)