

QuickNet™ Cassette Cable Manager and Patch Field Protection Cover

PANDUIT®

SPECIFICATION SHEET

specifications

The fiber cassette rear cable manager (FQCRCM) organizes MTP* interconnect cable and traditional fiber cable for SFQ (Small Form-factor QuickNet™) series MTP* fiber optic cassettes, HDQ (High-Density QuickNet™) series high density fiber optic cassettes, and pre-terminated cable assemblies with cassettes. The cassette rear cable manager mounts to the rear of a standard EIA 19" wide telecommunications rack and provides a secure location to support a maximum of sixteen MTP* interconnect cable assemblies. Interconnect cables and traditional fiber cables shall be secured with fiber management spools.

The fiber patch field protection cover (FPFPC1) hides and protects the front patch field and shall minimize the potential for connector damage and fiber attenuation. The labeling card identifies ports and d-rings provide physical support and route fibers into the vertical manager.



FQCRCM



FPFPC1

technical information

Dimensions: 1.40"H x 19.0"W x 9.56"D (35.7mm x 482.6mm x 242.9mm) (cassette rear cable manager) 1.72"H x 19.38"L (43.71mm x 492.25mm) (patch field protection cover)

Mounting options: Mounts to standard EIA 19" racks

key features and benefits

Cassette Rear Cable Manager (FQCRCM)

Rear mounting design

Provides easy access to fiber cable; rear mounting design conserves data center floor space by reducing or eliminating the need for horizontal cable managers; occupies less than 1 RU space

Fiber management spools

Improved fiber protection, ease of maintenance, and enhanced cable management; manages rear fiber cable slack and provides for fiber cable routing guide; fiber management spools organize cables for optimum finished appearance

Modularity

Offers flexibility by accommodating QuickNet™ MTP* Interconnect Cable and traditional fiber cable; for use with QuickNet™ SFQ Series MTP* Fiber Optic Cassettes, QuickNet™ HDQ Series High Density Fiber Optic Cassettes, and QuickNet™ Pre-Terminated Cable Assemblies with Cassettes

Fiber Patch Field Protection Cover (FPFPC1)

Front post installation

Hides front patch field, protects front patch field. Mounts into a variety of Panduit Racks and Cabinets including 2-post and 4-post racks, Net-SERV and Ne-Access cabinet and directly supports Opticom, MiniCom, and QuickNet FAPs, Adapter Panels, and Cassettes

Labeling card and d-rings

Identifies patch field for optimum organization. D-rings provide physical support to fiber, and routes fiber into vertical manager

applications

The SFQ cassette rear cable manager is used to support and manage MTP* Interconnect Cable and traditional fiber cable. It provides strain relief, bend radius control, superior aesthetics, and improved organization and routing of cables. The QuickNet™ Cassette Rear Cable Manager is less than 1 RU high, and is designed to support MTP* Interconnect Cable from up to sixteen QuickNet™ SFQ Cassettes or up to two QuickNet™ HDQ Cassettes installed in 2 RU space. The QuickNet™ Cassette Rear Cable Manager installs on the rear of a standard EIA 19" rack.

QuickNet™ Fiber patch Field Protection Cover mounts into a variety of Panduit Racks and Cabinets including 2-post and 4-post racks, Netserve and NetAccess cabinets. Directly supports Opticom, MiniCom, and QuickNet FAPs, Adapter Panels, and Cassettes. Protects front patch field and minimizes the potential for connector damage and fiber attenuation. The QuickNet Cassette Rear Cable Manager and Fiber Patch Field Protection Cover contribute to network integrity and reduce time and cost associated with cable routing and maintenance.

www.panduit.com

QuickNet™ Cassette Rear Cable Manager

Fiber cassette rear cable manager: FQCRCM

QuickNet™ Fiber Patch Field Protection Cover

1 RU fiber patch field protection cover: FPFPC1

QuickNet™ HDQ Series High Density Fiber Optic Cassettes – B-Type Port Labeling

10Gig 50/125µm OM4: F1RBZN-9608-10[^]
Optimized 10Gig 50/125µm OM4: F1RBZO-9608-10[^]
10Gig 50/125µm OM3: F1RBNX-9608-10[^]
Optimized 10Gig 50/125µm OM3: F1RBNXO-9608-10[^]

QuickNet™ HDQ Series High Density Fiber Optic Cassettes – C-Type Port Labeling

10Gig 50/125µm OM4: F1RCZN-9612-10[^]
Optimized 10Gig 50/125µm OM4: F1RCZO-9612-10[^]
10Gig 50/125µm OM3: F1RCXN-9612-10[^]
Optimized 10Gig 50/125µm OM3: F1RCXO-9612-10[^]

QuickNet™ HDQ Series Angled High Density Fiber Optic Cassettes – S-Type Port Labeling

10Gig 50/125µm OM4: F1ASZN-9612-10[^]
Optimized 10Gig 50/125µm OM4: F1ASZO-9612-10[^]
10Gig 50/125µm OM3: F1ASXN-9612-10[^]
Optimized 10Gig 50/125µm OM3: F1ASXO-9612-10[^]

QuickNet™ MTP* Trunk Cable Assemblies

12-fiber: FSPX1255F^{^^}A
24-fiber: FSPX2455F^{^^}A
48-fiber: FSPX4855F^{^^}A

QuickNet™ MTP* Interconnect Cable Assemblies (Female MTP* to Female MTP*)

12-fiber: FX12D5-5M^{^^}Y

QuickNet™ Cassette MTP* Cleaning Tool

For all MTP* connectors: FIBCCCT

Reel Type MTP* Connector Cleaning Tools

Female MTPs*: FMTPFCT
Male MTPs*: FMTPMFCT
Reel refill (qty. 6): FMTPRR6

[^]Use S for Standard Polarity and F for Flipped Polarity.
^{^^}100, 150, and 200 ft. are standard lengths; additional lengths are available. Contact Customer Service for actual lead times.
 *MTP is a registered trademark of Conec Ltd.

QuickNet™ Cassette Rear Cable Manager

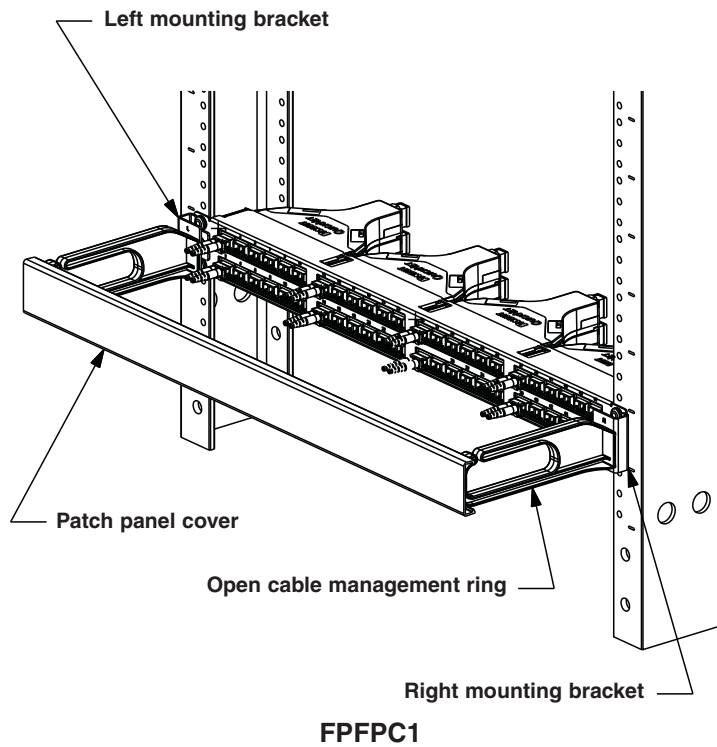
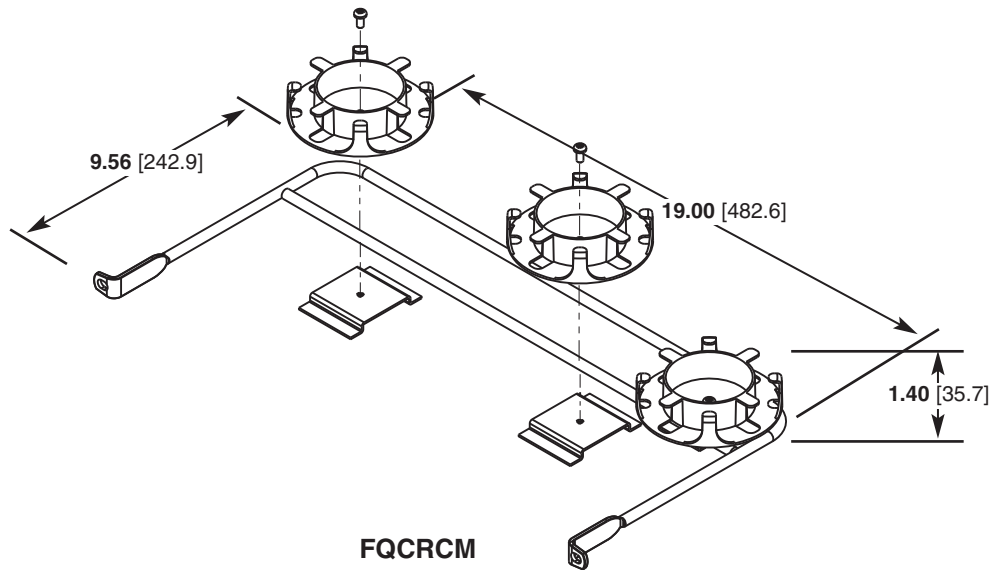

Dimensions are in inches. [Dimensions in brackets are metric].

WORLDWIDE SUBSIDIARIES AND SALES OFFICES

PANDUIT CANADA
Markham, Ontario
cs-cdn@panduit.com
Phone: 800.777.3300

PANDUIT EUROPE LTD.
London, UK
cs-emea@panduit.com
Phone: 44.20.8601.7200

PANDUIT SINGAPORE PTE. LTD.
Republic of Singapore
cs-ap@panduit.com
Phone: 65.6305.7575

PANDUIT JAPAN
Tokyo, Japan
cs-japan@panduit.com
Phone: 81.3.6863.6000

PANDUIT LATIN AMERICA
Guadalajara, Mexico
cs-la@panduit.com
Phone: 52.33.3777.6000

PANDUIT AUSTRALIA PTY. LTD.
Victoria, Australia
cs-aus@panduit.com
Phone: 61.3.9794.9020

For a copy of Panduit product warranties, log on to www.panduit.com/warranty

For more information

Visit us at www.panduit.com

Contact Customer Service by email: cs@panduit.com
or by phone: 800.777.3300

PANDUIT®

©2013 Panduit Corp.
ALL RIGHTS RESERVED.
FBSP60--WW-ENG
Replaces FBSP44
2/2013

X-ON Electronics

Largest Supplier of Electrical and Electronic Components

Click to view similar products for [Fibre Optic Cable Assemblies](#) category:

Click to view products by [Panduit](#) manufacturer:

Other Similar products are found below :

[7-21002-9](#) [MDM-25SH006F-A174](#) [MDM-25SH011F-A174](#) [FA04390-50-M-72-LC-N](#) [MLB 501 V RED](#) [MLB 501 V YELLOW](#) [MLN 1002,5](#)
[RED](#) [1-3636-600-5208](#) [1-5018030-0](#) [2061529-7](#) [21055-6](#) [FXBSCSCE2LM002](#) [3000005](#) [3-21053-2](#) [MLB 200/1 V BLACK](#) [MLB 2001 V](#)
[RED](#) [MLB 2001 V YELLOW](#) [MLB 501 V BLACK](#) [5492011-6](#) [106284-7000](#) [5492011-5](#) [5492011-8](#) [5492011-9](#) [8-21007-5](#) [106386-4447](#)
[2123909-4](#) [106273-0629](#) [2125046-1](#) [2821236-3](#) [2821310-2](#) [2821310-3](#) [2821313-4](#) [FX2ERLNLNSNM0.5](#) [CF-980062-074](#)
[FCBG410QD3C10](#) [CF-901200-394](#) [CF-980062-073](#) [CF-980062-071](#) [CF-980062-075](#) [CF-980062-072](#) [17-300310-100](#) [2821236-2](#) [MIKROE-](#)
[3728](#) [FA04474](#) [1083665](#) [17-300870-23](#) [TCP-Q151B-NNE22](#) [N821-100M-AQ-AR](#) [1115533](#) [1115548](#)