

QuickNet™ Fiber Cabling in the Data Center

PANDUIT®

**APPLICATION
GUIDE**

Your network drives the critical data, voice, video, and security applications required to support your business. QuickNet™ Fiber Cabling System simplifies the delivery of those network services by providing reliable infrastructure components assembled and tested in a factory-controlled environment. An end-to-end cabling system is an ideal solution for data centers especially when time for traditional cable installation, termination, and testing is limited. QuickNet™ Fiber Cabling System components are terminated, tested and configured to fit the application, offering quick, plug-in deployment for trouble free network performance.

With the benefits of quick network deployment, assured performance, quality, and easy redeployment, the Panduit® QuickNet™ Fiber Cabling System is the perfect infrastructure solution for today's data centers.



Quick Reference

QuickNet™ Fiber Cabling Systems	2
QuickNet™ Fiber Cable Assembly Options	3
How to Use QuickNet™ Fiber Cable Assemblies	4
How to Configure QuickNet™ Fiber Cable Assemblies	8
Guide for Measuring QuickNet™ Fiber Cable Assembly Lengths	11
Common QuickNet™ Part Numbers	13
QuickNet™ Fiber Accessory Part Numbers	19

QuickNet™ Fiber Cabling Systems

Available in a range of configurations, these factory terminated cable assemblies meet the unique needs of data center projects of any scale.

This guide covers common considerations for using QuickNet™ Fiber Cabling Systems:

- Applications in the data center
- QuickNet™ Fiber Termination options and common configurations
- Specifying options, measuring for lengths and selecting QuickNet™ Fiber part numbers



QuickNet™ Fiber Applications in the Data Center

QuickNet™ products can be used for a wide variety of permanent link cable assembly needs that are common in data center architectures such as Middle of Row or End of Row configurations, shown in Figure 1.

Figure 1 – Data Center Applications

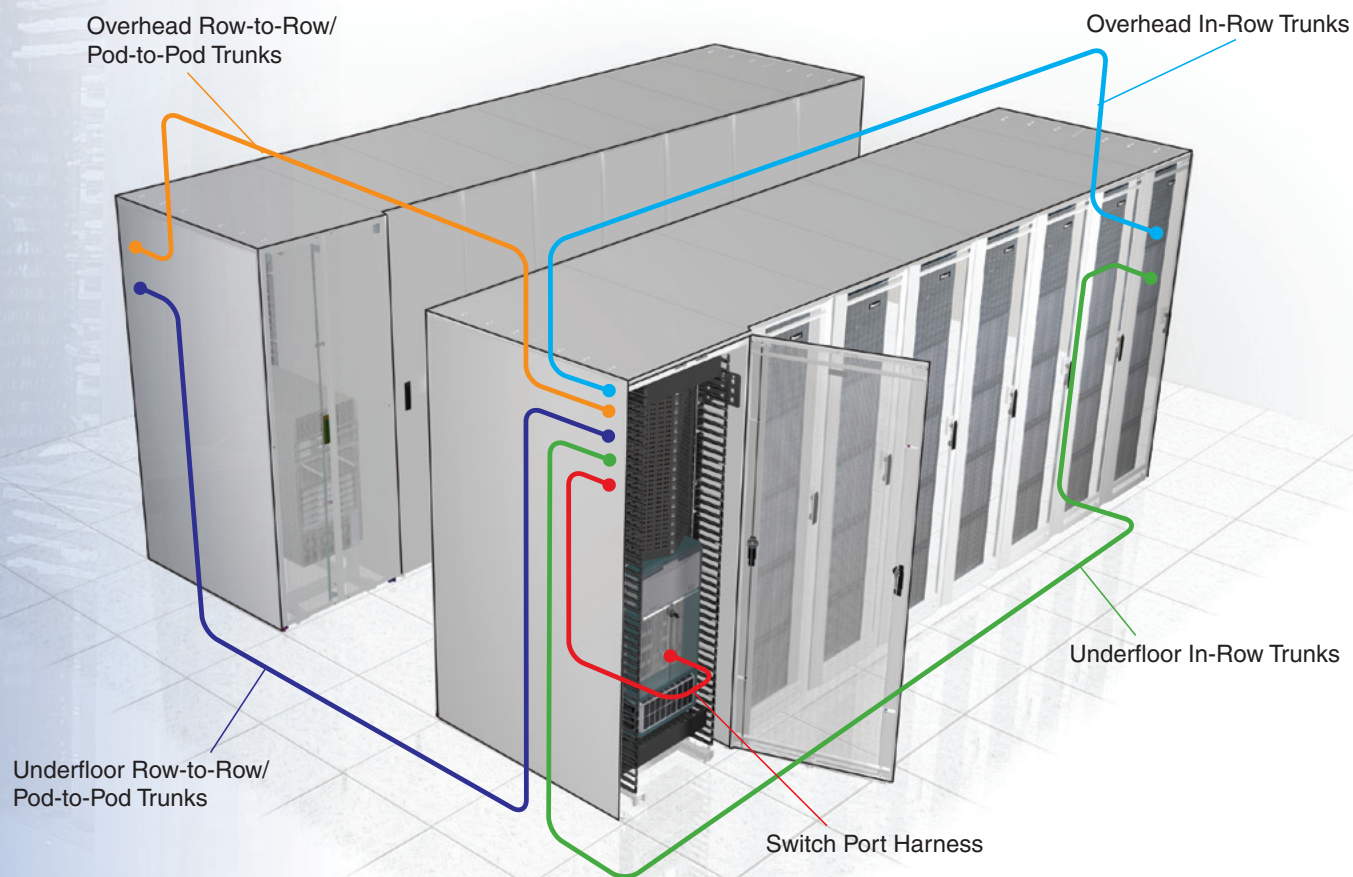

QuickNet™ Fiber Cable Assembly Options

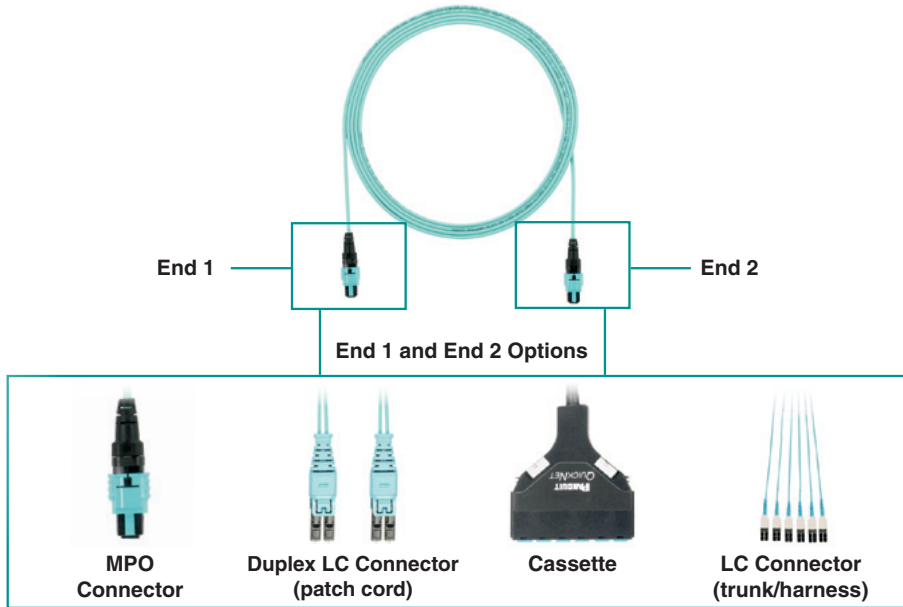

Common QuickNet™ Fiber Cable Assembly Configurations

Duplex LC to Duplex LC Patch Cord

- Patch cord with duplex LC connectors on both ends
- Typically used in cross-connect and interconnect applications in data centers
- Connect to pre-terminated cassettes in main, horizontal, and equipment distribution

MPO to MPO Trunks/Interconnect

- Trunk or interconnect fiber cable with 12-fiber MPO connector(s) on each end
- Trunks offer greater mechanical protection (3x crush) than interconnects and are built with pulling eyes. Preferred for lengths >30m/100 ft.
- Typically used in cabinet-to-cabinet permanent backbone links
- Installs into QuickNet™ Fiber Adapter Panels (FAP) or cassettes in common architectures with cassettes enabling quick installation into panels
- Available in male (pins), female (no pins), or changeable configurations

MPO to LC Harness

- Trunk or harness cable with 12-fiber or 8-fiber LC connector(s) on one end and one MPO connector on the other end
- Typically used as equipment cord harnesses
- Installs into QuickNet™ Patch Panels on one end and switch ports on the other end

Cassette to Cassette Trunk

- Cassette of either 12 LC or 4, 6, 8 MPO connectors on each end
- Typically used for inter-row connectivity
- Factory tested as permanent link (does not require re-test in the field)

Cassette to MPO Trunk

- Cassette of either 12 LC or 4, 6, 8 MPO connectors on one end to discrete connectors on the other end.
- Typically used for inter-row connectivity

Cassette to LC Trunk

- Cassette of either 12 LC or 4, 6, 8 MPO connectors on one end to discrete connectors on the other end.
- Typically used for inter-row connectivity

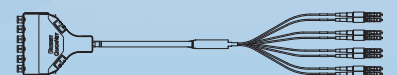
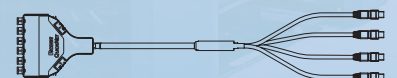
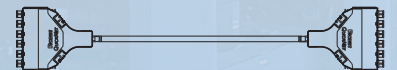
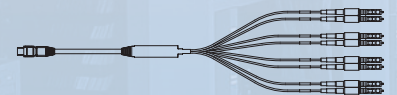
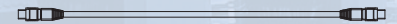

How to Use QuickNet™ Fiber Cable Assemblies

The following sections illustrate and describe in greater detail how QuickNet™ Fiber Trunks, Interconnects, Harnesses, and Patch Cords are used in common data center cabling configurations.

Two-Connector Interconnect

In this configuration, a permanent link is installed between QuickNet™ Patch Panels in the switch/network cabinet and the server or storage cabinets. The most common, flexible and upgradeable QuickNet™ Fiber solution is shown in Figure 2, below.

Figure 2 – Two-Connector Interconnect

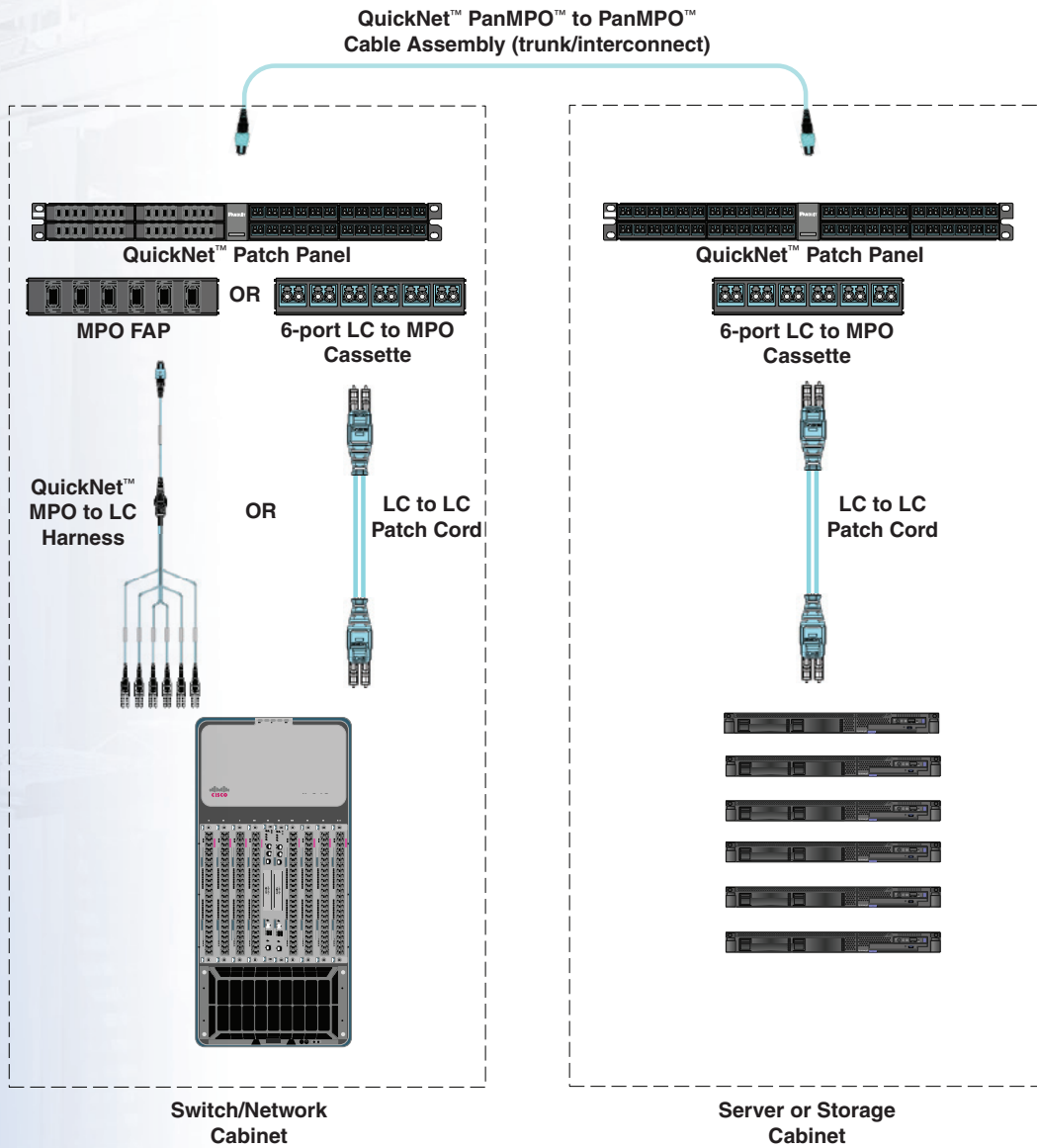

Four-Connector Cross Connect

In this configuration, permanent links are installed between QuickNet™ Patch Panels in the switch/network cabinet and server or storage cabinets and a common cross connect cabinet or rack. In this scenario, any fiber from any switch port or server uplink can be routed to anywhere within the datacenter. This option allows for the easy moves, adds, or changes. The most common, flexible, and upgradeable QuickNet™ Fiber solution is shown in Figure 3, below.

Figure 3 – Four-Connector Cross Connect

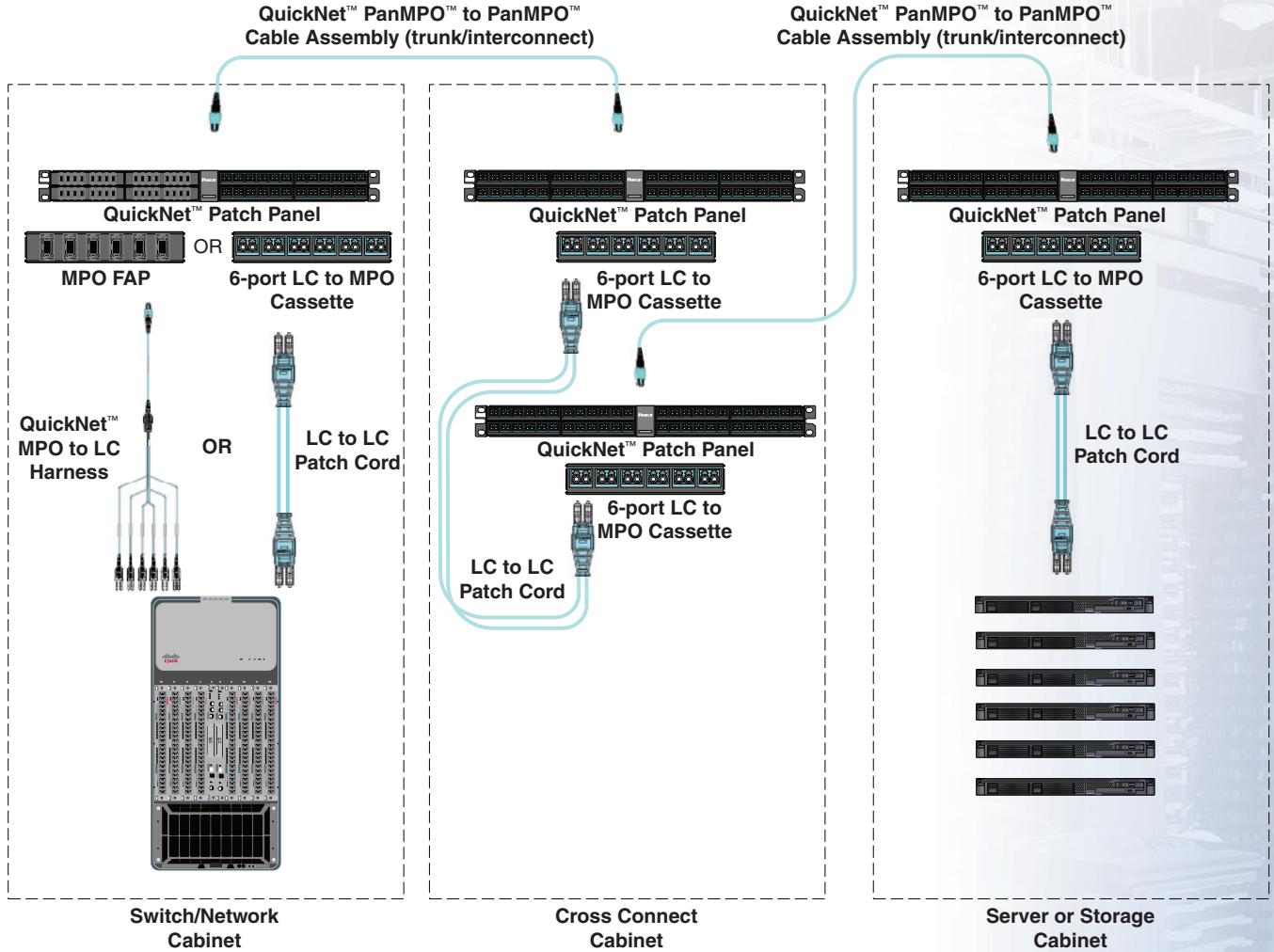

Switch Port Equipment Harnesses

Switch port equipment harnesses are utilized in the switching area of the data center to simplify patching and consolidate cabling. The LC to MPO harnesses connect six (6) or four (4), depending on the switch blade layout, LC transceivers in the switch to a single MPO connector in an adapter panel installed in the switch cabinet or within 15m of the switch cabinet. This allows for consolidation of the switch ports. Panduit switch port equipment harnesses come in three different breakout arrangements shown below in Figure 4. Figure 5 illustrates the application.

Figure 4 – Harness Configurations

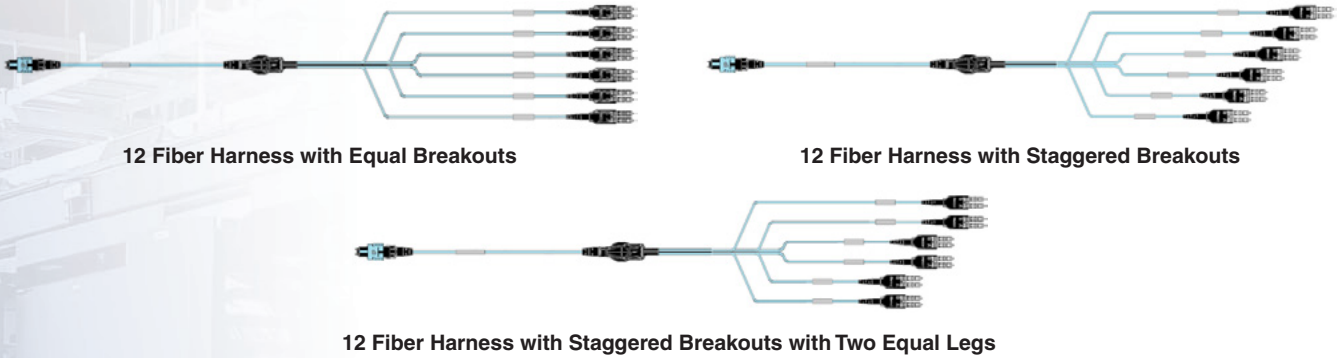
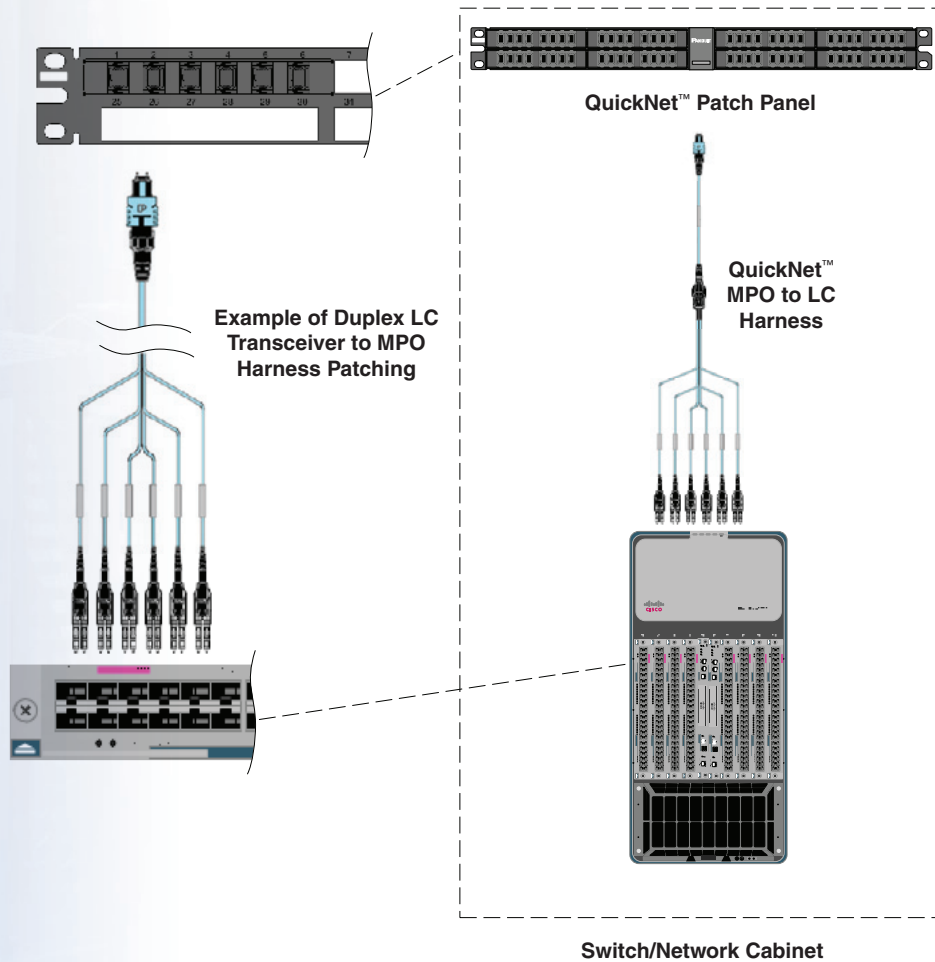

Figure 5 – Switch Port Equipment Harnesses



HDQ Series High Density Cassettes

The QuickNet™ HDQ Series High Density Fiber Optic Cassettes can be used in high density network applications for cross connects to assist with switch port replication. These cassettes mirror 32-port and 48-port Cisco® blades and 32-port, 48-port and 64-port Brocade™ blades as shown in Figure 6. These give the end user at a cross connect area the ability to visualize the switch when conducting moves, adds, or changes. Panduit also offers generic 48-port and 72-port HDQ cassettes.

Figure 6 – HDQ Example

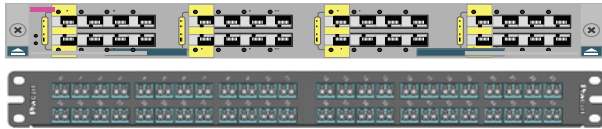

Cisco® 32-Port Blade and Corresponding Panduit Cassette F1RC-6412-10S**

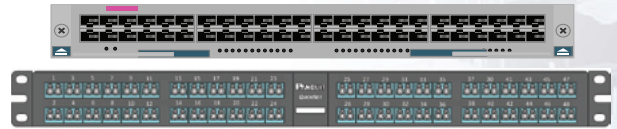

Cisco® 48-Port Blade and Corresponding Panduit Cassette F1RC-9612-10S**

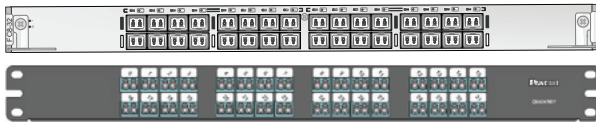

Brocade™ 32-Port Blade and Corresponding Panduit Cassette F1RB-6408-10S**

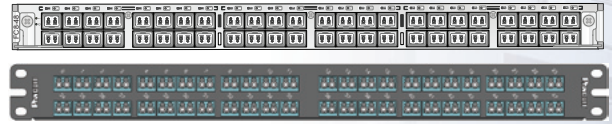

Brocade™ 48-Port Blade and Corresponding Panduit Cassette F1RB-9608-10S**

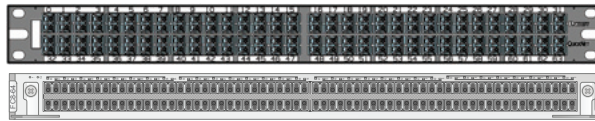

Brocade™ 64-Port Blade and Corresponding Panduit Cassette F1RB-1B08-10S**

**= Performance and fiber type

Figure 7 – HDQ Series High Density Cassettes

QuickNet™ PanMPO™ to PanMPO™ Cable Assembly (Trunk/Interconnect)

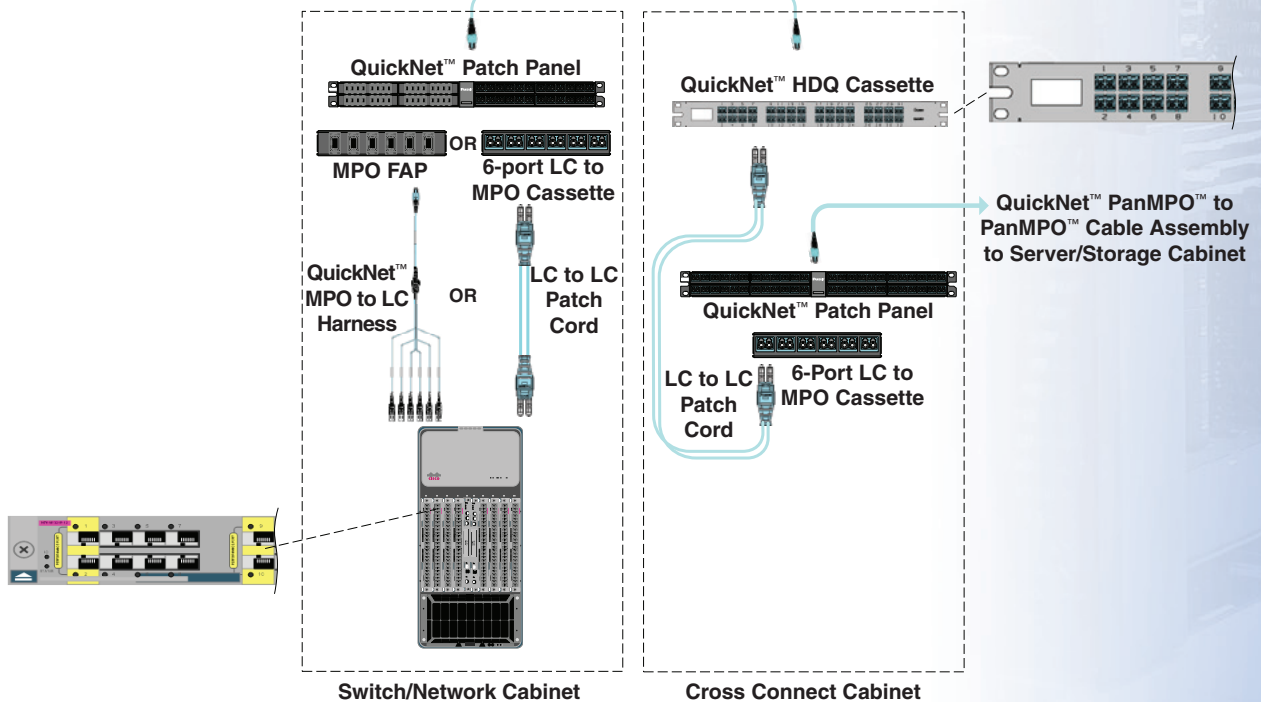

^Cisco and Cisco Systems are registered trademarks of Cisco Technology, Inc.

^^Brocade is a registered trademark of Brocade Communications Systems, Inc.

How to Configure QuickNet™ Fiber Cable Assemblies

The QuickNet™ Fiber product family has a wide range of available configuration options from standard MPO to MPO cable assemblies to fully custom assemblies that are user-defined in a number of areas. In this section, each of the main configuration options for QuickNet™ Fiber are explained and typical considerations for data center applications are covered.

Fiber Type

The fiber type of the cable selected in the assembly indicates the maximum data rate that the cable assembly will support and should be selected to support the active equipment speeds projected over the life of the cabling.

Cable choices:

- OS1/OS2 (Singlemode)
- OM3
- OM4

Laser optimized multimode fibers (MMF) exceed domestic and international standards for optical fiber, including TIA 492AAAB, TIA 492AAAC, TIA 492AAAD and IEC 60793 2 10 and support a diverse set of legacy and contemporary applications including Ethernet and Fiber Channel among many others. For 10GbE applications, the following link lengths are supported:

- OS1/OS2: 10km
- OM3: 300m
- OM4: 400m

Cable color for all performance levels:

- OS1/OS2: Yellow
- OM3: Aqua
- OM4: Aqua

Additional guidance on the supported link reaches for data center applications with various channel insertion losses is available at www.panduit.com.

Fiber Count

Fiber count choices and outside diameters:

- 12F: small diameter 4.5mm
- 24F: small diameter 5.4mm
- 48F: 9.4mm
- 72F: 9.4mm
- 96F: 10.0mm
- 144F: 11.1mm

Cable Flame Rating

Cable flame rating choices are:

- Low Smoke Zero Halogen (LSZH), tested to IEC 60332, 60754, and 610345
- Optical Fiber Non-Conductive Plenum (OFNP), tested to NFPA 262
- Optical Fiber Non-Conductive Riser (OFNR), tested to UL-1666

Low Smoke Zero Halogen (LSZH) rated cable is jacketed with compounds that emit limited smoke and no halogen when exposed to high heat sources. It is the preferred jacket in EMEA.

Plenum (OFNP) is jacketed with a fire-retardant plastic. It is required for installations in the United States.

Riser (OFNR) cables contain no electrically conductive materials. These are used in a contained area, usually a vertical shaft.

Trunk Type and Terminations

Both ends of a QuickNet™ Fiber cable assembly include one of a range of factory termination options – each end can be different and are selected based upon the desired application of the trunk or harness within the data center.

Termination choices are:

- Duplex LC to Duplex LC
- MPO to MPO
- MPO to LC
- Cassette to Cassette
- Cassette to MPO/Duplex LC

Insertion Loss is the amount of power lost at each mated pair of connectors. Standard fiber Insertion Loss Performance per connector is:

- Multimode MPO to MPO: 0.50dB
- Multimode LC to LC: 0.25dB
- Singlemode MPO to MPO: 0.75dB
- Singlemode LC to LC: 0.35dB

Optimized fiber Insertion Loss Performance per connector is:

- Multimode MPO to MPO: 0.35dB
- Multimode LC to LC: 0.15dB

All components in the channel/link MUST "be optimized" performance to ensure a channel/link meets or exceeds "optimized" insertion losses. The most common QuickNet™ termination combinations for permanent link horizontal cable trunks are MPO to MPO. Cassette terminations are preferred for inter-row connectivity.

For equipment cord harnesses, MPO to LC terminations are used.

Five different staggered configurations are available to assist in dressing from either top to bottom or side to side. Termination options are: (shown in Figure 4)

- Equal breakout
- 6 staggered breakout with fiber 1 shortest (left to right or bottom to top cabling)
- 6 staggered breakout with fiber 1 longest (right to left or top to bottom cabling)
- 3 staggered breakout with fibers 1 and 2 shortest (left to right or bottom to top cabling)
- 3 staggered breakout with fibers 1 and 2 longest (right to left or top to bottom cabling)

Note: A staggered breakout is a fiber pair.

Assembly Options

The main assembly option available is:

- Pulling Eye

A pulling eye is a loop of braided sleeve material that is applied to one end of the QuickNet™ Trunk Assembly, and is used to aid in laying the cable in pathways at deployment.

Note: Panduit recommends that all QuickNet™ assemblies be laid into data center pathways during deployment; however, if pulling of the assemblies is required, care must be taken to ensure the assemblies are not pulled across sharp edges or corners which can damage the glass. In addition, pulling eyes cannot be used on an end that has a cassette termination and interconnect assemblies do not contain pulling eyes.

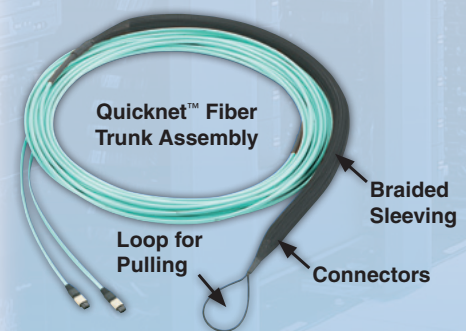

Figure 8 – Pulling Eye Option



Figure 9 – Labels

Labeling

All QuickNet™ Fiber Cable Assemblies have an assembly label on each end which includes the part number, length, description, and a serialized quality control number. Label example shown in Figure 9.

Length of Assembly

Length options are:

- Trunks: 16 ft. to 300 ft. in 1 foot increments; 5m to 100m in 1m increments
- Interconnects: 1 ft. to 150 ft. in 1 foot increments; 1m to 50m in 1m increments
- LC Patch Cords: 1m to 50m, in 1m increments
- Harnesses: 1 ft. to 100 ft. in 1 foot increments; 1m to 30m in 1m increments

The length of a QuickNet™ Fiber Cable Assembly is the total distance from the terminated connector on one end to the terminated connector on the other. For staggered assemblies, the distance is measured from the longest end of the stagger.

Common QuickNet™ Accessories

(See page. 18 for a full list of QuickNet™ accessories and part numbers)

QuickNet™ Patch Panels:

- Designed to enable rapid installation
- Available in angled or flat versions, standard or all metal, and in standard density (24 ports in 1 RU) or high density (48 ports in 1 RU)
- QuickNet™ Patch Panels include horizontal numbering; for Cassette-terminated switch port harnesses, QuickNet™ High Density Patch Panels with vertical numbering are available with odd numbers across the top row of ports and even numbers across the bottom (to emulate switch port numbering)

QuickNet™ Patch Panel Blank:

- QuickNet™ Panel Blanks are available to block out temporarily unused openings in QuickNet™ Patch Panels to ensure proper airflow.

Other variations may be possible, contact Panduit Customer Service for more information.

Figure 10 – Accessories

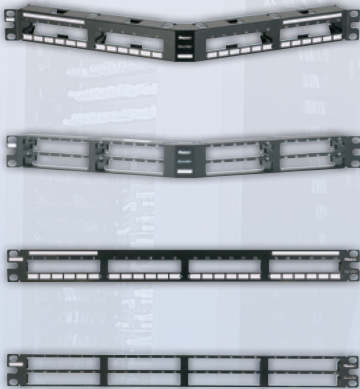

QuickNet™ Patch Panels



QuickNet™ Panel Blank

Guide for Measuring QuickNet™ Fiber Cable Assembly Lengths

Proper measuring for QuickNet™ Fiber Cable Assembly lengths is straightforward but does require some detailed information about the data center layout. For the most accurate length measurements, it is best to work from layout drawings and know the specific equipment to be used, the cabinet dimensions, and the desired positions in the cabinets of patch panels and equipment.

The illustration below shows a typical data center link and the sections that must be considered to properly measure for QuickNet™ Fiber Cable Assembly lengths. This example shows an overhead in-row installation. For other configurations, adjust accordingly. (For example, with underfloor configurations, measure down from the panels to the pathway).

Recommended Steps for Measuring QuickNet™ Fiber Cable Assembly Lengths:

1. Calculate or measure the length of each section of the link.
 - a. Harness length: $A1 + A2$
 - b. Horizontal cable length: $B + C + D$
2. Round the total upward to the nearest foot to get the minimum QuickNet™ Fiber Cable Assembly length.

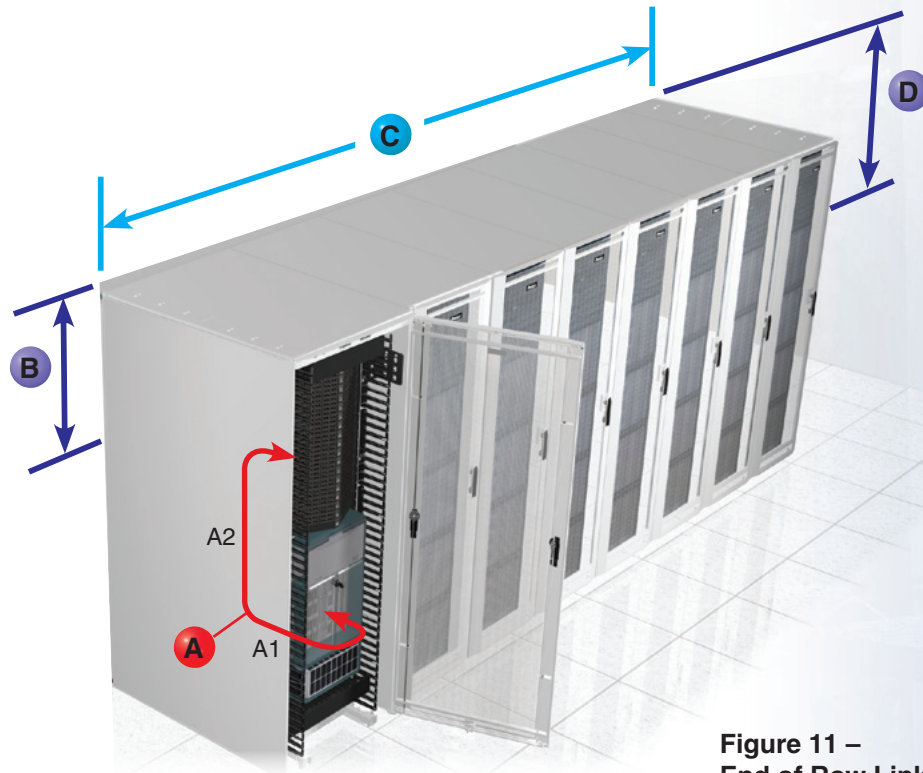

Figure 11 –
End of Row Link

Link Sections and Guide for Measuring:

- A In-cabinet length:** The total length of the cable inside the cabinet ($A1 + A2$).
 - A1 – Horizontal distance from switch face to vertical manager – Panduit recommends 1m breakout or stagger to allow for cable routing and management.
 - A2 – Distance from vertical manager to patch panel in cabinet – this can vary depending upon where the patch panel is located within the cabinet.
- B Patch panel-to-pathway length:** The distance from the patch panel in cabinet to the cable pathway.
- C Length along pathway:** The total distance along the pathway between the cabinet entry/exit points.
- D Pathway-to-patch panel length:** Similar to B.

Length Measurement Example

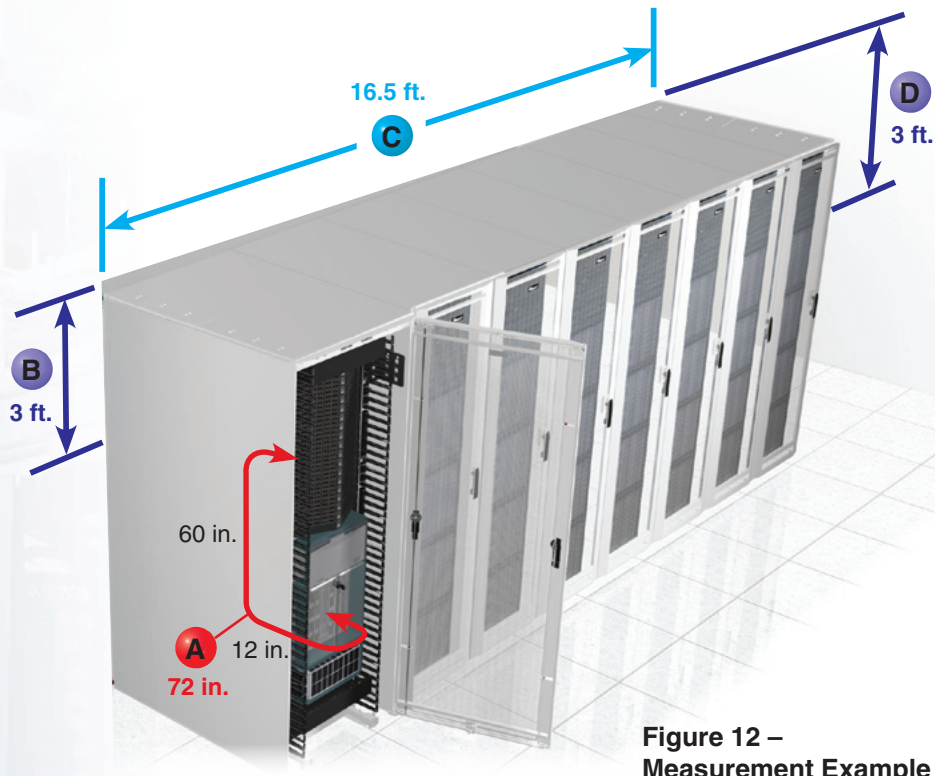

Figure 12 –
Measurement Example

Example: In-cabinet length: 72 in. (12 in. + 60 in.)

- A** A1 – Distance from switch plate to vertical manager = 12 in.
A2 – Distance from vertical manager to patch panel = 60 in.
- B** Patch panel-to-pathway length: 3 ft.
- C** Length along pathway: 16.5 ft. (assuming seven 24 in. wide server cabinets and cable exit on far side of 30 in. wide network cabinet = (7 x 2 ft.) + 30 in.)
- D** Pathway-to-patch panel length: 3 ft.

Total harness length = (12 in. + 60 in.) = 72 in. = **6 ft.**

Total horizontal cable length = (3 ft. + 16.5 ft. + 3 ft.) = 22.5 ft. = **23 ft.**

Tips for Measuring Lengths:

- The specified length of a QuickNet™ Fiber Cable Assembly is the distance as measured from the front of the connector on one end to the front of the connector on the other end. Other than a nominal manufacturing tolerance there is no additional length built into a QuickNet™ Fiber Cable Assembly.
- Remember to account for any turns or obstructions in the pathway that may lead to additional length needed (for example, ducting, support posts, etc.).
- Cable assembly bend radius limits must be taken into consideration, especially for multiple turns within cabinets or as the cable assembly transitions to or from the pathways, and may require additional length of the assembly.

Common QuickNet™ Part Numbers

QuickNet™ Fiber Cable Assemblies – Common Part Numbers

Opti-Core® Fiber Optic Patch Cords and Pigtails

Steps to Select:

- 1 Select Cable Options
- 2 Select Ends 1 and 2
- 3 Select Construction/Performance
- 4 Select Length

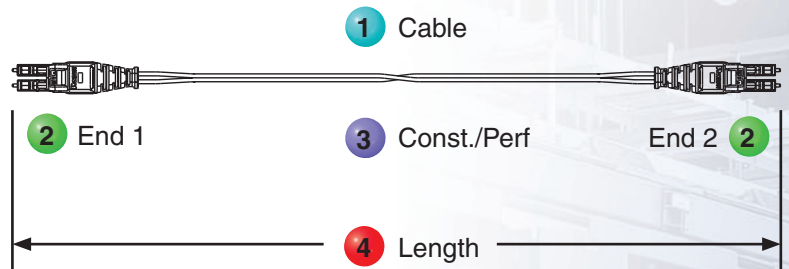

Fiber		Cable			End 1		End 2		Const./Perf	Other	Length			
Fiber	Count	Cable	Jacket	Connector	No Variant	Connector	No Variant		None	Unit	3-digit Length			
F	X	2	E	R	Q	N	Q	N	S	N	M	0	0	5

Fiber Type

9 = OS1/OS2 9/125µm
X = OM3 50/125µm
Z = OM4 50/125µm

Fiber Count

1 = 1-fibers
2 = 2-fibers

Cable Type

B = 900µm buffer
E = 1.6mm

Jacket Type

L = Low Smoke Zero Halogen (LSZH)
R = Optical Fiber Nonconductive Riser (OFNR)
P = Optical Fiber Nonconductive Plenum (OFNP)

Connector Type End 1

1 = LC
3 = SC
A = SC-APC
L = LC duplex
N = None (pigtail)
Q = Push-Pull LC duplex
S = SC duplex

Connector Type End 2

1 = LC
3 = SC
A = SC-APC
L = LC duplex
N = None (pigtail)
Q = Push-Pull LC duplex
S = SC duplex

Construction/Performance

S = Standard IL – (A-B)
O = Optimized IL – (A-B)

Length

1m to 50m (001-050)
1m increments

Unit of Length

M = Meters

Above part number **FX2ERQNQNSNM005**: Fiber, OM3 50/125µm 2-fiber 1.6mm riser, LC push-pull connector to LC push-pull connector, standard IL, 5m.

QuickNet™ Fiber Cable Assemblies – Common Part Numbers

QuickNet™ Round Interconnect Cable Assemblies

Steps to Select:

- 1 Select Cable Options
- 2 Select Ends 1 and 2
- 3 Select Construction/Performance
- 4 Select Length

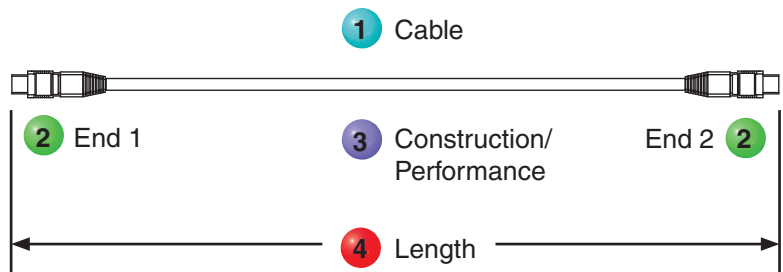

Fiber		Cable			End 1		End 2		Const./Perf Other		Length						
Fiber	Count	Cable	Jacket	Connector	No Variant	Connector	No Variant		None	Unit	3-digit Length						
F	X	T	R	P	7	N	7	N	A	N	M	0	0	1			
Fiber Type 9 = OS1/OS2 9/125µm X = OM3 50/125µm Z = OM4 50/125µm		Fiber Count T = 12-fibers		Cable Type R = 3.0mm round indoor		Jacket Type L = Low Smoke Zero Halogen (LSZH) P = Optical Fiber Nonconductive Plenum (OFNP)		Connector Type End 1 5 = MPO female 6 = MPO male 7 = PanMPO™ female* 8 = PanMPO™ male*		Connector Type End 2 5 = MPO female 6 = MPO male 7 = PanMPO™ female* 8 = PanMPO™ male*		Construction/Performance A = Polarity A – standard IL B = Polarity B – standard IL X = Polarity A – optimized IL Y = Polarity B – optimized IL		Length 1m to 50m (001-050) 1m increments 3 ft. to 150 ft. (003-150) 1 ft. increments		Unit of Length M = Meters F = Feet	

Above part number **FXTRP7N7NANM001**: Fiber, OM3 50/125µm 12-fiber 3.0mm round indoor OFNP cable with PanMPO™ female connectors with no variants on both ends, Polarity A – standard IL, 1m in length.

*PanMPO™ option is only available with multimode (OM3/OM4) assemblies.

QuickNet™ Fiber Cable Assemblies – Common Part Numbers (cont.)

QuickNet™ Small Diameter Trunk Cable Assemblies

Steps to Select:

- 1 Select Cable Options
- 2 Select Ends 1 and 2
- 3 Select Construction/Performance
- 4 Select Pulling Eye Option
- 5 Select Length

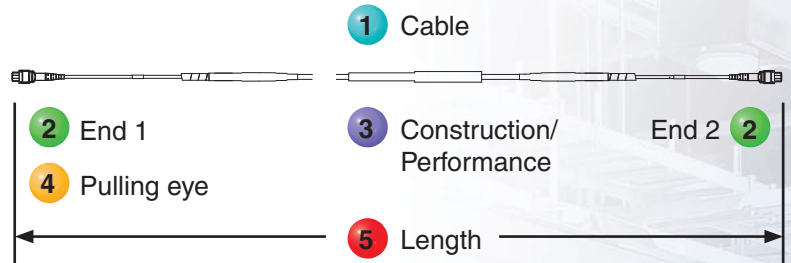

Fiber		Cable			End 1		End 2		Const./Perf Other		Length			
Fiber	Count	Cable	Jacket	Connector	Variant	Connector	Variant		Other	Unit	3-digit Length			
F	X	U	Y	P	5	E	5	E	A	A	F	1	0	0

Fiber Type

9 = OS1/OS2 9/125µm
X = OM3 50/125µm
Z = OM4 50/125µm

Fiber Count

T = 12-fiber
U = 24-fiber

Cable Type

Y = Indoor small diameter trunk cable

Jacket Type

L = Low Smoke Zero Halogen (LSZH)
P = Optical Fiber Non-conductive Plenum (OFNP)

Connector Type End 1

5 = MPO female
6 = MPO male
7 = PanMPO™ female*
8 = PanMPO™ male*
L = LC Duplex

Connector Variant

E = 1m breakout
2 = 2mm overjacket (LC only)

Connector Type End 2

5 = MPO female
6 = MPO male
7 = PanMPO™ female*
8 = PanMPO™ male*
L = LC Duplex

Connector Variant

E = 1m breakout
2 = 2mm overjacket/
1m breakout (LC only)

Construction/Performance

A = Polarity A – standard IL (MPO – MPO)
B = Polarity B – standard IL (MPO – MPO)
X = Polarity A – optimized IL (MPO – MPO)
Y = Polarity B – optimized IL (MPO – MPO)
S = Standard IL – (A – B), MPO-LC or LC-LC
O = Optimized IL – (A – B) MPO-LC or LC-LC

Other

A = Pulling eye End 1

Length

5m to 100m (005-100)
1m increments
16 ft. to 300 ft. (016-300)
1 ft. increments

Unit of Length

M = Meters
F = Feet

Above part number FXUYP5E5EAAF100: Fiber, OM3 50/125µm 24-fiber indoor small diameter trunk plenum cable with MPO female connectors on both ends with 1m breakout variant, Polarity A-standard IL, Pulling eye on End 1, 100 ft. in length. Longer lengths are available.

*PanMPO™ option is only available with multimode (OM3/OM4) assemblies.

QuickNet™ Fiber Cable Assemblies – Common Part Numbers

QuickNet™ Trunk Cable Assemblies

Steps to Select:

- 1 Select Cable Options
- 2 Select Ends 1 and 2
- 3 Select Construction/Performance
- 4 Select Pulling Eye Option
- 5 Select Length

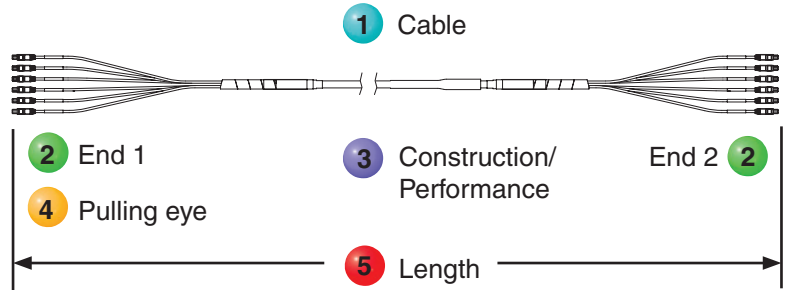

Fiber		Cable			End 1		End 2		Const./Perf Other		Length			
Fiber	Count	Cable	Jacket	Connector	Variant	Connector	No Variant			Unit	3-digit Length			
F	X	X	S	P	5	E	5	E	A	A	F	1	0	0

Fiber Type

9 = OS1/OS2 9/125µm
X = OM3 50/125µm
Z = OM4 50/125µm

Fiber Count

W = 48-fibers
X = 72-fibers

Cable Type

S = Indoor trunk

Jacket Type

L = Low Smoke Zero Halogen (LSZH)
P = Optical Fiber Non-conductive Plenum (OFNP)

Connector Type End 1

5 = MPO female
6 = MPO male
L = LC duplex

Connector Variant

E = 1m breakout
2 = 2mm overjacket (LC only)

Connector Type End 2

5 = MPO female
6 = MPO male
L = LC duplex

Connector Variant

E = 1m breakout
2 = 2mm overjacket (LC only)

Construction/Performance

A = Polarity A – standard IL (MPO – MPO)
B = Polarity B – standard IL (MPO – MPO)
X = Polarity A – optimized IL (MPO – MPO)
Y = Polarity B – optimized IL (MPO – MPO)
S = Standard IL – (A – B), MPO-LC or LC-LC
O = Optimized IL – (A – B) MPO-LC or LC-LC

Other

A = Pulling eye End 1

Length

5m to 100m (005-100)
1m increments
16 ft. to 30 ft. (016-030)
1 ft. increments

Unit of Length

M = Meters
F = Feet

Above part number **FXXSP5E5EAAF100**: Fiber, OM3 50/125µm 72-fiber indoor trunk plenum cable with MPO female to MPO female connectors with 1m breakout, Polarity A-standard IL, pulling eye on End 1, 100 ft. in length.

QuickNet™ Fiber Cable Assemblies – Common Part Numbers (cont.)

QuickNet™ Harness and Staggered Harness Cable Assemblies

Steps to Select:

- 1 Select Cable Options
- 2 Select Ends 1 and 2
- 3 Select Construction/Performance
- 4 Select Length

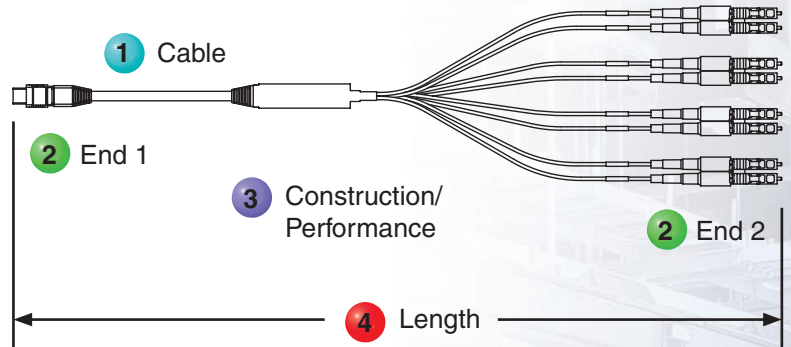

Fiber		Cable			End 1		End 2		Const./Perf Other		Length			
Fiber	Count	Cable	Jacket	Connector	No Variant	Connector	Variant		None	Unit	3-digit Length			
F	X	T	R	P	6	N	L	S	S	N	M	0	0	3

Fiber Type

9 = OS1/OS2 9/125µm
 X = OM3 50/125µm
 Z = OM4 50/125µm

Fiber Count

8 = 8-fiber
 T = 12-fiber

Cable Type

H = Flat ribbon (OS1/OS2)
 R = 3.0mm round indoor (OM3/OM4)

Jacket Type

L = Low Smoke Zero Halogen (LSZH)
 P = Optical Fiber Nonconductive Plenum (OFNP)

Connector Type End 1

5 = MPO female
 6 = MPO male
 7 = PanMPO™ female*
 8 = PanMPO™ male*

Connector Type End 2

L = LC duplex
 U = LC uniboot PanMPO™ (OM3/OM4 only)

Connector Variant

D = 1m equal breakout
 S = 61cm equal breakout
 N = No variant
 F = Staggered pair 1 longest breakout
 G = Staggered pair 1 shortest breakout
 H = Staggered pairs 1 and 2 longest breakouts
 J = Staggered pairs 1 and 2 shortest breakouts

Construction/Performance

S = Standard IL – straight thru (A-B)
 O = Optimized IL – straight thru (A-B)
 Q = QSFP to SFP+

Length

1m to 30m (001-030)
 1m increments
 3 ft. to 100 ft. (030-100)
 1 ft. increments

Unit of Length

M = Meters
 F = Feet

Above part number **FXTRP6NLSSNM003**: Fiber, OM3 50/125µm 12-fiber 3.0mm round OFNP with MPO male connectors with no variant on End 1 and LC Duplex connectors with 61cm equal breakout on End 2, Standard IL-straight thru (MPO Discrete), 3m in length.

*PanMPO™ option is only available with multimode (OM3/OM4) assemblies.

QuickNet™ Fiber Cable Assemblies – Common Part Numbers

QuickNet™ SFQ Trunk Cable Assemblies

Steps to Select:

- 1 Select Cable Options
- 2 Select Ends 1 and 2
- 3 Select Construction/Performance
- 4 Select Length

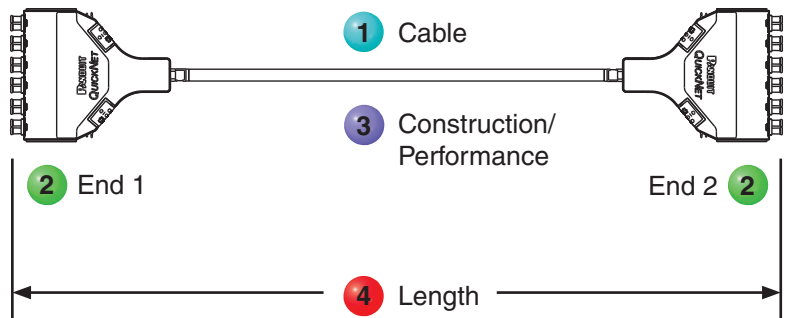

Fiber		Cable			End 1		End 2		Const./Perf Other		Length				
	Fiber	Count	Cable	Jacket	Connector	None	Connector	None		None	Unit	3-digit Length			
F	X	T	S	P	X	N	X	N	S	N	M	0	3	0	
Fiber Type		Fiber Count		Cable Type		Jacket Type		Connector Type End 1		Connector Type End 2		Construction/Performance		Length	
9 = OS1/OS2 9/125µm X = OM3 50/125µm Z = OM4 50/125µm		T = 12-fibers W = 48-fibers X = 72-fibers Y = 96-fibers		S = Indoor trunk		L = Low Smoke Zero Halogen (LSZH) P = Optical Fiber Nonconductive Plenum (OFNP)		V = MPO female cassette X = LC cassette (12F only) Y = MPO male cassette		V = MPO female cassette X = LC cassette (12F only) Y = MPO male cassette 5 = MPO female connectors 6 = MPO male connectors 7 = PanMPO™ female connectors 8 = PanMPO™ male connectors L = LC Duplex connectors		A = Polarity A – standard IL (MPO – MPO) S = Standard IL – (A – B), MPO-LC or LC-LC		5m to 30m (005-030) 1m increments 15 ft. to 100 ft. (003-100) 1 ft. increments	
												Unit of Length			
												M = Meters F = Feet			

Above part number **FXTSPXNXNSNM030**: Fiber, OM3 50/125µm 12-fiber indoor trunk OFNP cable with LC Cassettes on each end with no variant, Polarity A standard IL, 30m in length.

*PanMPO™ option is only available with multimode (OM3/OM4) assemblies.

QuickNet™ Fiber Accessory Part Numbers

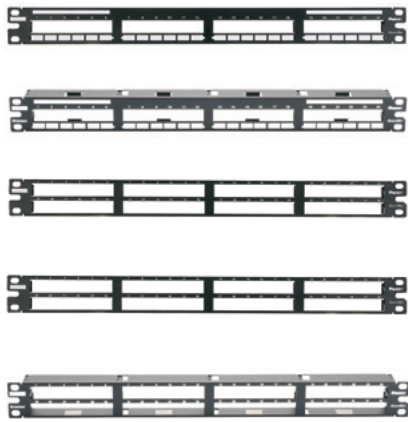
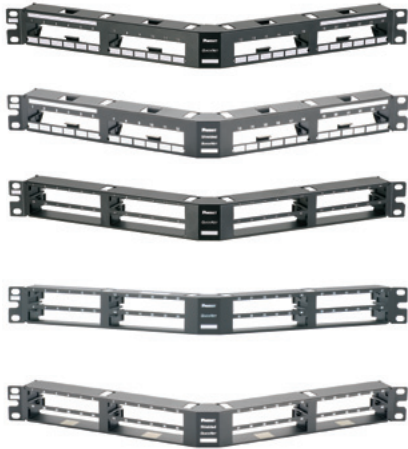

Part Number	Part Description	No. of Rack Spaces	Std. Pkg. Qty.	Std. Ctn. Qty.
QuickNet™ Angled Patch Panels				
QAPP24BL	24-port, angled patch panel which accepts QuickNet™ Pre-Terminated Cassettes and Patch Panel Adapters.	1	1	10
QASP24BL	24-port, all metal angled patch panel which accepts QuickNet™ Pre-Terminated Shielded Cassettes and Patch Panel Adapters.			
QAPP48HDBL	48-port, angled patch panel which accepts QuickNet™ Pre-Terminated Cassettes and Patch Panel Adapters.			
QAPP48HDVNSBL	48-port, angled patch panel which accepts QuickNet™ Pre-Terminated Cassettes and Patch Panel Adapters. Numbering sequence is top to bottom across patch panel.			
QASP48HDBL	48-port, all metal angled patch panel which accepts QuickNet™ Pre-Terminated Shielded Cassettes and Patch Panel Adapters.			
QuickNet™ Flat Patch Panels				
QPP24BL	24-port, patch panel which accepts QuickNet™ Pre-Terminated Cassettes and Patch Panel Adapters.	1	1	10
QSP24BL	24-port, all metal patch panel which accepts QuickNet™ Pre-Terminated Shielded Cassettes and Patch Panel Adapters.			
QPP48HDBL	48-port, patch panel which accepts QuickNet™ Pre-Terminated Cassettes and Patch Panel Adapters.			
QPP48HDVNSBL	48-port, patch panel which accepts QuickNet™ Pre-Terminated Cassettes and Patch Panel Adapters. Numbering sequence is top to bottom across patch panel.			
QSP48HDBL	48-port, all metal patch panel which accepts QuickNet™ Pre-Terminated Shielded Cassettes and Patch Panel Adapters.			
Patch Panel Blank				
QPPBBL	QuickNet™ Patch Panel Blank reserves space for future use and promotes proper airflow and cooling. Use QPPLC24 for label/label cover.	1	1	10
Patch Panel Label Kit				
QPPLC24	Label/label cover kit for 24-port QuickNet™ Patch Panels. Each kit contains four labels and four clear label covers per bag.	1	1	10

PANDUIT®

building a smarter,
unified business foundation

Connect. Manage. Automate.

Complete Solutions from Panduit

Panduit cabinet and rack systems offer a portfolio of innovative products with modular designs for greater thermal management, with energy efficiency, and effective space utilization while managing, showcasing, and protecting equipment.

Panduit Difference

Panduit is committed to delivering a consistently high level of quality and service the world over. With a presence in more than 100 countries, local Panduit sales representatives and technical specialists offer guidance and support that bring value to your business. Our global supply chain, which includes manufacturing, customer service, logistics, and distribution partners, provides prompt response to your inquiries and streamlines delivery to any worldwide destination.

DISCLAIMER: The information contained herein is intended as a guide for use by persons having technical skill at their own discretion and risk. Before using, buyer shall determine the suitability of the Panduit product for his intended use and buyer assumes all risk and liability whatsoever in connection therewith.

WORLDWIDE SUBSIDIARIES AND SALES OFFICES

Panduit Canada
Markham, Ontario
cs-cdn@panduit.com
Phone: 800.777.3300

Panduit Europe Ltd.
London, UK
cs-emea@panduit.com
Phone: 44.208.601.7200

Panduit Singapore Pte. Ltd.
Republic of Singapore
cs-ap@panduit.com
Phone: 65.6305.7575

Panduit Japan
Tokyo, Japan
cs-japan@panduit.com
Phone: 81.3.3767.7011

Panduit Latin America
Guadalajara, Mexico
cs-la@panduit.com

Phone: 52.33.3777.6000
Panduit Australia Pty. Ltd.
Victoria, Australia
cs-aus@panduit.com
Phone: 61.3.9794.9020

For a copy of
Panduit product warranties,
log on to www.panduit.com/warranty

For more information
Visit us at www.panduit.com

Contact Customer Service by email:
cs@panduit.com
or by phone: 800-777-3300

X-ON Electronics

Largest Supplier of Electrical and Electronic Components

Click to view similar products for [Wire Ducting](#) category:

Click to view products by [Panduit](#) manufacturer:

Other Similar products are found below :

[66200A-10](#) [CVED32VEPG](#) [CVED40VEPG](#) [F512D5-5F140Y](#) [F512D5-5F200Y](#) [F512D5-5F26Y](#) [F512D5-5F30Y](#) [F512D5-5F33Y](#) [F512D5-5F34Y](#) [F512D5-5F45Y](#) [F512D5-5F50Y](#) [F512D5-5F54Y](#) [F512D5-5F66Y](#) [F512D5-5F70Y](#) [F512D5-5F75Y](#) [F512D5-5F90Y](#) [F612D5-5F100Y](#) [F612D5-5F130Y](#) [F612D5-5F50Y](#) [F612D5-5F56Y](#) [F612D5-5F58Y](#) [F6L12D5-5F46](#) [F912D5-5F11Y](#) [F912D5-5F170Y](#) [F912D5-5F175Y](#) [F912D5-5F230Y](#) [F912D5-5F300Y](#) [F912D5-5F55Y](#) [F912D5-5F56Y](#) [F912D5-5F63Y](#) [F912D5-5F6Y](#) [F912D5-5F75Y](#) [F912D5-5F85Y](#) [F912D5-5F86Y](#) [F912D5-5F88Y](#) [F912D5-5F96Y](#) [FAP0047WBLMTP](#) [FAP12WBRDRDDLZ](#) [FAP12WDYLYLDLZ](#) [FAP12WEORORDLZ](#) [FAP6WEORORDLZ](#) [FAP6WFDBDBDLZ](#) [FAP8WEORORDLZ](#) [FCE2UWCL](#) [800A-LB](#) [802A-ECSP](#) [802I-ICSP](#) [FJQADH](#) [FJQFXT](#) [PED10](#)