

QuickNet™ SFQ Series MPO Fiber Adapter Panels (FAPs)

PANDUIT®

SPECIFICATION SHEET

specifications

Small Form Factor QuickNet™ (SFQ) MPO FAPs contain FOCIS 5 compatible fiber optic adapters and meet or exceed TIA/EIA-568-C.3 requirements. Variations include panels with 4, 6, or 8 MPO adapters in either key-up to key-up or key-up to key-down configurations. Maximum density allows for 64 MPO ports in a 1RU space when used in conjunction with QuickNet™ Patch Panels. All SFQ FAPs snap quickly into the rear of QuickNet™ Patch Panels for easy network deployment and quick migration from 10G to 40/100G infrastructure.



technical information

Standards requirements:	All adapters meet or exceed TIA/EIA-568-C.3 requirements MPO: TIA-604-5-D; FOCIS 5 compatible	
Insertion loss and Return loss:	Supports the performance of Panduit Multimode and Singlemode MPO Patch Cords	
	Standard Multimode MPO Patch Cords:	0.50dB Max IL; 20dB Min RL
	Optimized Multimode OM3 and OM4 MPO Patch Cords:	0.35dB Max IL; 26dB Min RL
	Singlemode MPO APC Patch Cords:	0.75dB Max IL; 55dB Min RL

key features and benefits

Snap quickly into QuickNet™ Patch Panels	Assures flexibility and ease of network deployment. Facilitates migration from 10G to 40/100G infrastructure	
MPO adapters follow TIA/EIA-568-C.3 and TIA-604-5-D polarity standards	Type A Polarity:	Black adapter housing with key-up to key-down configuration; K=1
	Type B Polarity:	Charcoal gray adapter housing with key-up to key-up configuration; K=2
MPO adapters offer a compact design for ultimate density	Fits into SC-sized simplex panel openings (See TIA/EIA-604-3 for full dimensional details)	

applications

The QuickNet™ SFQ Series Fiber Adapter Panels are a component of the QuickNet™ Fiber Optic Cabling System. QuickNet™ SFQ Series Fiber Adapter Panels are used in high-density network applications as specified in the Data Center Cabling Standard TIA 942 for cross connects in main distribution, horizontal distribution, and equipment distribution areas. The QuickNet™ Pre-Terminated Cabling System meets the demands of Gigabit Ethernet, 10 Gigabit Ethernet, and high-speed Fibre Channel

systems while maintaining compatibility with Ethernet, Fast Ethernet, and ATM. QuickNet™ SFQ Series Fiber Optic Cassettes, MPO Fiber Adapter Panels and QuickNet™ Copper Cable Assemblies are interchangeable within QuickNet™ Angled and Standard Patch Panels, enabling deployment flexibility and a unified pre-terminated solution. This ensures efficient use of space, quick deployment and the highest reliability for the lowest installed cost.

www.panduit.com

QuickNet™ SFQ MPO FAPs – Type A Black Adapters

FAP with 4 MPO key-up/key-down adapters:	FQMAP45BL
FAP with 6 MPO key-up/key-down adapters:	FQMAP65BL
FAP with 8 MPO key-up/key-down adapters:	FQMAP85BL

QuickNet™ SFQ MPO FAPs – Type B Charcoal Gray Adapters

FAP with 4 MPO key-up/key-up adapters:	FQMAP45CG
FAP with 6 MPO key-up/key-up adapters:	FQMAP65CG
FAP with 8 MPO key-up/key-up adapters:	FQMAP85CG

Fiber Optic MPO Adapter

MPO adapter; Type A; FAMPOBLA‡

Key up to key down, black

MPO adapter; Type B; FAMPOCGB‡

Key up to key up, charcoal gray

‡ Listed as single piece. Available in pks. of 10.

Add -X to end of part number

QuickNet™ MTP* Trunk Cable Assemblies (Female MTP* to Female MTP*) – Plenum (OFNP) Rated

12-fiber:	FSP^1255F+++A
24-fiber:	FSP^2455F+++A
48-fiber:	FSP^4855F+++A

QuickNet™ MTP* Trunk Cable Assemblies (Male MTP* to Male MTP*) – Plenum (OFNP) Rated

12-fiber:	FSP^1266F+++A
24-fiber:	FSP^2466F+++A
48-fiber:	FSP^4866F+++A

QuickNet™ MTP* Trunk Cable Assemblies (Female MTP* to Male MTP*) – Plenum (OFNP) Rated

12-fiber:	FSP^1256F+++A
24-fiber:	FSP^2456F+++A
48-fiber:	FSP^4856F+++A

QuickNet™ MTP*/MPO Multimode Interconnect Round Cable Assemblies Female to Female – Plenum (OFNP) Rated

OM4 – 10Gig™ 50/125um:	FZN0505RTPM001
Optimized OM4 – 10Gig™ 50/125um:	FZP0505RTPM001
OM3 – 10Gig™ 50/125um:	FXN0505RTPM001
Optimized OM3 – 10Gig™ 50/125um:	FXP0505RTPM001
OM2 – 50/125um:	F5N0505RTPM001

QuickNet™ MTP*/MPO Multimode Interconnect Round Cable Assemblies Male to Male – Plenum (OFNP) Rated

OM4 – 10Gig™ 50/125um:	FZN0606RTPM001
Optimized OM4 – 10Gig™ 50/125um:	FZP0606RTPM001
OM3 – 10Gig™ 50/125um:	FXN0606RTPM001
Optimized OM3 – 10Gig™ 50/125um:	FXP0606RTPM001
OM2 – 50/125um:	F5N0606RTPM001

QuickNet™ Cassette MTP* Cleaning Tool

All MTP* connectors:	FIBCCCT
----------------------	---------

QuickNet™ Patch Panels

Angled 24-port:	QAPP24BL
Angled 48-port:	QAPP48HDBL
Standard 24-port:	QPP24BL
Standard 48-port:	QPP48HDBL

QuickNet™ Zero RU Cassette Bracket

Holds 2 cassettes:	FQCBRUA
--------------------	---------

*MTP is a registered trademark of US Conec Ltd.

^Z = 550 meter reach 10Gig™ Multimode OM4 (12-fiber only), X = 300 meter reach 10Gig™ Multimode OM3, 5 = 50/125um Multimode OM2, 6 = 62.5/125um Multimode OM1, 9 = Singlemode OS1/OS2

+++Standard lengths for MTP* to MTP* OM3/OM4, 12, 24 and 48 fiber are available from 40 to 200 feet in increments of 5 feet. Ex: FSPX1255F040A (40ft. length) to FSPX1255F100A (100ft. length.) For additional lengths and availability, please contact Panduit Customer Service.

QuickNet™ SFQ Series MPO Fiber Adapter Panels (FAPs)

MPO Fiber Adapter Panels

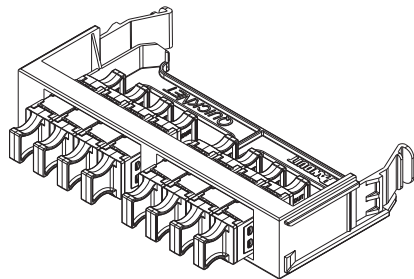

Angled view of fiber adapter panel
(Shown with dust caps)

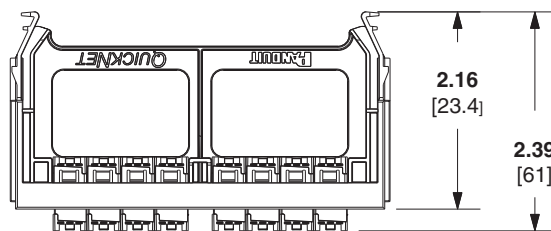

Top view of fiber adapter panel

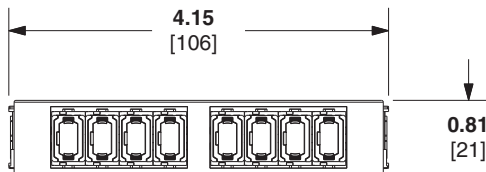

Front view of fiber adapter panel

MPO Fiber Adapter

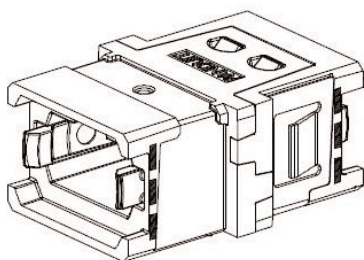

MPO adapter
(Shown with dust caps removed)

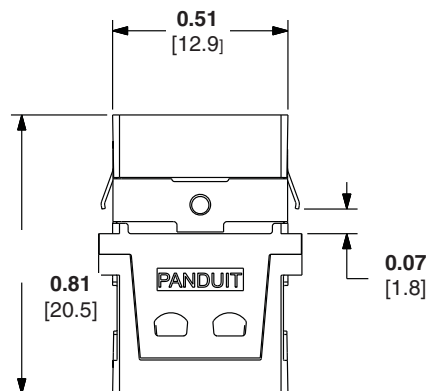

Top view of MPO adapter

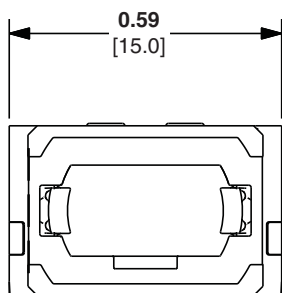

Front view of MPO adapter

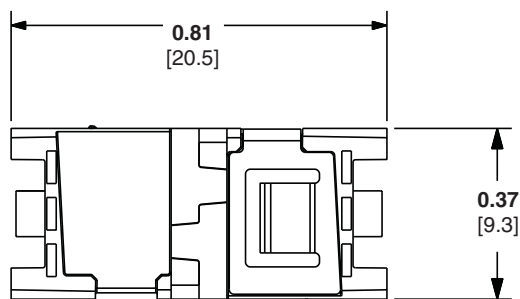

Side view of MPO adapter

Dimensions are in inches. [Dimensions in brackets are metric].

WORLDWIDE SUBSIDIARIES AND SALES OFFICES

PANDUIT CANADA
Markham, Ontario
cs-cdn@panduit.com
Phone: 800.777.3300

PANDUIT EUROPE LTD.
London, UK
cs-emea@panduit.com
Phone: 44.20.8601.7200

PANDUIT SINGAPORE PTE. LTD.
Republic of Singapore
cs-ap@panduit.com
Phone: 65.6305.7575

PANDUIT JAPAN
Tokyo, Japan
cs-japan@panduit.com
Phone: 81.3.6863.6000

PANDUIT LATIN AMERICA
Guadalajara, Mexico
cs-la@panduit.com
Phone: 52.33.3777.6000

PANDUIT AUSTRALIA PTY. LTD.
Victoria, Australia
cs-aus@panduit.com
Phone: 61.3.9794.9020

For a copy of Panduit product warranties, log on to www.panduit.com/warranty

For more information

Visit us at www.panduit.com

Contact Customer Service by email: cs@panduit.com
or by phone: 800.777.3300 and reference FBSP46

PANDUIT®

©2012 Panduit Corp.
ALL RIGHTS RESERVED.
WW-FBSP46
6/2012

X-ON Electronics

Largest Supplier of Electrical and Electronic Components

Click to view similar products for [Wire Ducting](#) category:

Click to view products by [Panduit](#) manufacturer:

Other Similar products are found below :

[66200A-10](#) [CVED32VEPG](#) [CVED40VEPG](#) [F512D5-5F140Y](#) [F512D5-5F200Y](#) [F512D5-5F26Y](#) [F512D5-5F30Y](#) [F512D5-5F33Y](#) [F512D5-5F34Y](#) [F512D5-5F45Y](#) [F512D5-5F50Y](#) [F512D5-5F54Y](#) [F512D5-5F66Y](#) [F512D5-5F70Y](#) [F512D5-5F75Y](#) [F512D5-5F90Y](#) [F612D5-5F100Y](#) [F612D5-5F130Y](#) [F612D5-5F50Y](#) [F612D5-5F56Y](#) [F612D5-5F58Y](#) [F6L12D5-5F46](#) [F912D5-5F11Y](#) [F912D5-5F170Y](#) [F912D5-5F175Y](#) [F912D5-5F230Y](#) [F912D5-5F300Y](#) [F912D5-5F55Y](#) [F912D5-5F56Y](#) [F912D5-5F63Y](#) [F912D5-5F6Y](#) [F912D5-5F75Y](#) [F912D5-5F85Y](#) [F912D5-5F86Y](#) [F912D5-5F88Y](#) [F912D5-5F96Y](#) [FAP0047WBLMTP](#) [FAP12WBRDRDDLZ](#) [FAP12WDYLYLDLZ](#) [FAP12WEORORDLZ](#) [FAP6WEORORDLZ](#) [FAP6WFDBDBDLZ](#) [FAP8WEORORDLZ](#) [FCE2UWCL](#) [800A-LB](#) [802A-ECSP](#) [802I-ICSP](#) [FJQADH](#) [FJQFXT](#) [PED10](#)