

# QuickNet™ 100G MPO Trunk Cable Assemblies and Adapter Panels

## technical information

QuickNet™ 24 Fiber MPO Pre-Terminated Trunk Cable Assemblies allow for rapid deployment of high-density permanent links for aggregation of 10G Ethernet and higher speed Fiber Channel Cabling. These cables and adapter panels facilitate direct attach or structured cabling capability for 100GBASE-SR10 applications and CXP or MXP optics requiring 24 fiber MPO interconnection at the transceiver media device interface. QuickNet™ Pre-Terminated Trunk Cable Assemblies optimize cable routing requirements to ensure efficient use of pathway space and significantly reduce installation time and cost. QuickNet™ Pre-Terminated Trunk Cable Assemblies are built with modular 24 fiber MTP\* connectivity and provide compatibility, flexibility and system performance in cabling applications requiring a TIA-FOCIS 5 compliant 24 fiber MPO interface at a cabling bulkhead adapter or transceiver receptacle interface. All Panduit® QuickNet™ Trunk Cable Assemblies are factory terminated and tested to deliver verified optical performance and reliability for improved network integrity. These trunk assemblies, when deployed in a channel, provide 40 Gb/s and 100 Gb/s network performance up to 100meters for OM3 and up to 125 meters for OM4 (per the IEEE 802.3ba 40/100 GbE Ethernet standard) while maintaining compatibility with legacy Ethernet and all ANSI Fibre Channel applications.

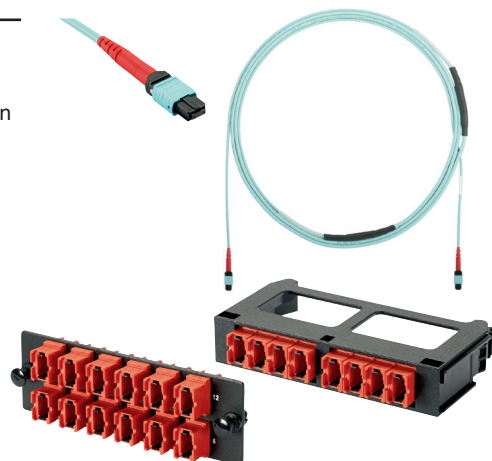

## application

Allows system design of efficient structured cabling systems in support of 100 Gb/s Ethernet Interconnects (IEEE 802.3ba Clause 86) and 10x10 Gb/s Ethernet Interconnects (802.3ae Clause 52) for Data Aggregation and Super High Density Cabling that service Datacom/Telecom Switch and Router Connections.

## construction

<b>Cable type:</b>	Indoor Small Diameter Trunk
<b>Cable jacket ratings:</b>	Low Smoke Zero Halogen (LSZH IEC 60332-1, 60332-3C, 60754-1, 61034-2) Optical Fiber Non Conductive Plenum (OFNP)
<b>Fiber types:</b>	Multimode: OM3, OM4 Singlemode: OS1/OS2
<b>Connector types end 'A':</b>	24-fiber: MPO female, MPO male
<b>Connector color end 'A':</b>	Multimode PC: Black and Aqua Singlemode APC: Black and Yellow
<b>Fiber Count:</b>	24
<b>Polarity:</b>	MPO-MPO: Method A
<b>Jacket color:</b>	OM3/OM4 Aqua OS1/OS2 Yellow
<b>Connector types end 'B':</b>	24-fiber: MPO female, MPO male
<b>Connector color end 'B':</b>	Multimode PC: Black and Aqua Singlemode APC: Black and Yellow

## optical properties

<b>Maximum cable attenuation:</b>	Singlemode: 1.0dB/km at 1310/1550nm Multimode: 3.5dB/km at 850nm 1.5dB/km at 1300nm
<b>Maximum connector insertion loss:</b>	Singlemode: 0.75dB Multimode: 0.50dB
<b>Minimum connector return loss:</b>	Singlemode: 55dB Multimode: 26dB

## physical properties

<b>Cable outside diameter (OD):</b>	5.4mm
<b>Minimum bend radius:</b>	Under load: 20 X Cable OD Static: 10 x Cable OD
<b>Cable tensile strength:</b>	660N
<b>Cable compressive load:</b>	10 N/mm
<b>Cable flex:</b>	25 cycles
<b>Connector cable retention:</b>	50N
<b>Connector durability:</b>	500 mating cycles
<b>Breakout outside diameter:</b>	3.0mm
<b>Transition outside diameter:</b>	10mm
<b>Pulling eye diameter:</b>	23mm
<b>Cable twist:</b>	10 cycles
<b>Breakout length:</b>	1m

## environmental properties

<b>Operating temperature:</b>	0 °C to +70 °C (32°F to +158°F)
<b>Storage and shipping temperature:</b>	-40 °C to +70 °C (-40°F to +158°F)
<b>Installation temperature:</b>	0 °C to +60 °C (32°F to +140°F)

## standards

Meets or exceeds ISO/IEC 11801, TIA/EIA-568-C.3, TIA-604-5 (FOCIS-5), TIC/EIA-568-C.1, RoHS Complaint

# QuickNet™ 100G MPO Trunk Cable Assemblies and Adapter Panels

## part number

Example: FXUYLEEEAAM030 = OM3, 24-fiber, indoor small diameter trunk cable, LSZH, 24F MPO female, 1m breakout to 24F MPO female, 1m breakout, Polarity A, pulling eye on end A, 30 meters

CHARACTER	1	2	3	4	5	6	7	8	9	10	11	12	13	14	15
EXAMPLE	F	X	U	Y	L	E	E	E	E	A	A	M	0	3	0

### 1 – Fiber Product

F = Fiber

### 2 – Fiber Type

9 = OS1/OS2 9/125µm

X = OM3 10Gig™ 50/125µm

Z = OM4 10Gig™ 50/125µm

### 3 – Fiber Count

U = 24-fiber

### 4 – Cable Type

Y = Indoor small diameter trunk cable

### 5 – Jacket Type

L = Low Smoke Zero Halogen (LSZH)

P = Optical Fiber Non Conductive

Plenum (OFNP)

### 6 – Connector Type (end A)

E = 24F MPO female

F = 24F MPO male

### 7 – Connector Variant

E = 1m breakout

### 8 – Connector Type (end B)

E = 24F MPO female

F = 24F MPO male

### 9 – Connector Variant

E = 1m breakout

### 10 – Construction/Performance

A = Polarity A, standard IL

B = Polarity B, standard IL

### 11 – Other

A = Pulling eye end A

C = Pulling eye both ends

### 12 – Unit of Length

M = Meters

F = Feet

### 13, 14, 15 – Cable Assembly Length

005 to 100m in increments of 5m

020 to 300 ft. in increments of 10 ft.

# QuickNet™ 100G MPO Trunk Cable Assemblies and Adapter Panels

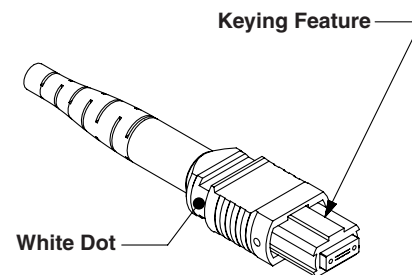
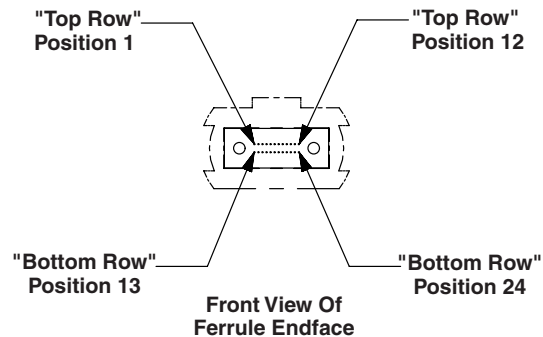
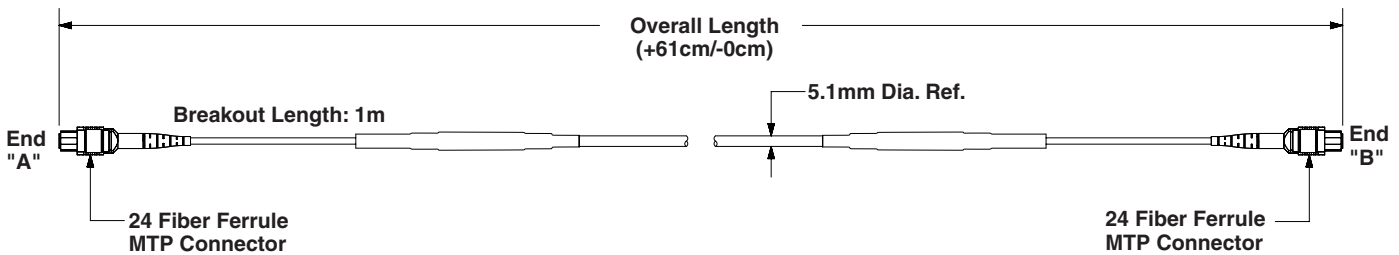

# QuickNet™ 100G MPO Trunk Cable Assemblies and Adapter Panels

## QuickNet™ 100G MPO Fiber Adapter Panels

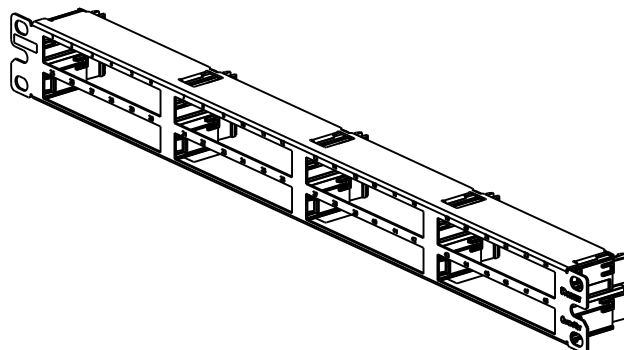
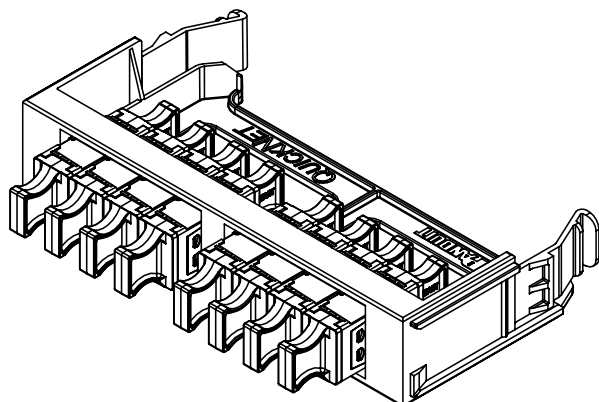

### QuickNet™ 100G MPO Fiber Adapter Panels (FAPs) and QuickNet™ Patch Panels

<b>QuickNet™ 100G MPO Fiber Adapter Panels (FAPs)</b> SFQ FAPs with Type A MPO Adapters (key-up/key-down)	FQMAP45RD, FQMAP65RD FQMAP85RD
<b>QuickNet™ Patch Panels</b>	QPP24BL, QAPP24BL, QPP48HDBL, QAPP48HDBL
<b>Opticom® Fiber Adapter Panels (FAPs) and Opticom® Patch Panels</b>	
<b>Opticom® Fiber Adapter Panels (FAPs)</b> FAPs with Type A MPO Adapters (key-up/key-down)	FAPH0424RDMPO, FAPH0624RDMPO, FAPH0824RDMPO FAPH1224RDMPO, FAPH1624RDMPO, FAPH1824RDMPO FAPV0424RDMPO, FAPV0624RDMPO, FAPV0824RDMPO
<b>Opticom® Patch Panels</b>	CFAPPBL1 CFAPPBL1A CFAPPBL2 CFAPPBL2A

### WORLDWIDE SUBSIDIARIES AND SALES OFFICES

PANDUIT CANADA  
Markham, Ontario  
cs-cdn@panduit.com  
Phone: 800.777.3300

PANDUIT EUROPE LTD.  
London, UK  
cs-emea@panduit.com  
Phone: 44.20.8601.7200

PANDUIT SINGAPORE PTE. LTD.  
Republic of Singapore  
cs-ap@panduit.com  
Phone: 65.6305.7575

PANDUIT JAPAN  
Tokyo, Japan  
cs-japan@panduit.com  
Phone: 81.3.6863.6000

PANDUIT LATIN AMERICA  
Guadalajara, Mexico  
cs-la@panduit.com  
Phone: 52.33.3777.6000

PANDUIT AUSTRALIA PTY. LTD.  
Victoria, Australia  
cs-aus@panduit.com  
Phone: 61.3.9794.9020

For a copy of Panduit product warranties, log on to [www.panduit.com/warranty](http://www.panduit.com/warranty)

For more information

Visit us at [www.panduit.com](http://www.panduit.com)

Contact Customer Service by email: [cs@panduit.com](mailto:cs@panduit.com)  
or by phone: 800.777.3300

**PANDUIT**®

©2015 Panduit Corp.  
ALL RIGHTS RESERVED.  
FBSP83--WW-ENG  
8/2015

## X-ON Electronics

Largest Supplier of Electrical and Electronic Components

*Click to view similar products for [Fibre Optic Cable Assemblies](#) category:*

*Click to view products by [Panduit](#) manufacturer:*

Other Similar products are found below :

[7-21002-9](#) [760-1518](#) [FA04390-50-M-72-LC-N](#) [MLB 501 V RED](#) [MLB 501 V YELLOW](#) [1-3636-600-5208](#) [2061529-7](#) [1-6693182-0](#)  
[1754898-1](#) [21055-6](#) [FXBSCSCE2LM002](#) [3000005](#) [3-21053-2](#) [MLB 200/1 V BLACK](#) [MLB 2001 V RED](#) [MLB 2001 V YELLOW](#) [MLB 501](#)  
[V BLACK](#) [5492011-6](#) [106284-7000](#) [5492011-5](#) [5492011-8](#) [5492011-9](#) [8-21007-5](#) [2123524-2](#) [2123524-1](#) [106386-4447](#) [DFSM-SCSC-2M](#)  
[2123909-4](#) [2123909-8](#) [106273-0629](#) [2125046-1](#) [2821236-3](#) [2821310-2](#) [2821310-3](#) [2821313-4](#) [FX2ERLNLNSNM0.5](#) [CF-980062-074](#) [CF-](#)  
[901200-394](#) [CF-980062-073](#) [CF-980062-071](#) [CF-980062-075](#) [CF-980062-072](#) [17-300310-100](#) [2821236-2](#) [2821313-1](#) [G-FC-FC-S-002.0-DX-](#)  
[A-18-Y](#) [G-E2A-E2A-S-003.0-SX-A-18-Y](#) [956-322-502214](#) [FA04474](#) [1083665](#)