

THIS COPY IS PROVIDED ON A RESTRICTED BASIS AND IS NOT TO BE USED IN ANY WAY DETRIMENTAL TO THE INTERESTS OF PANDUIT CORP.

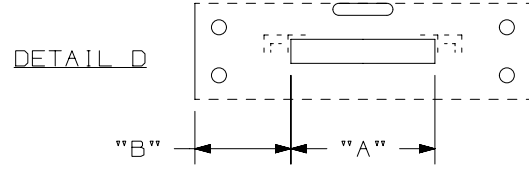

STYLE A

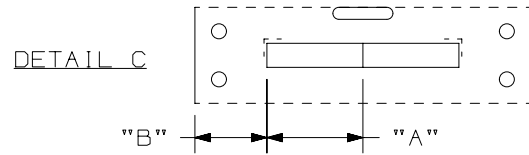
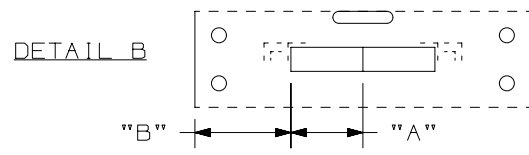
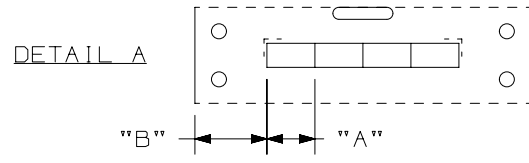
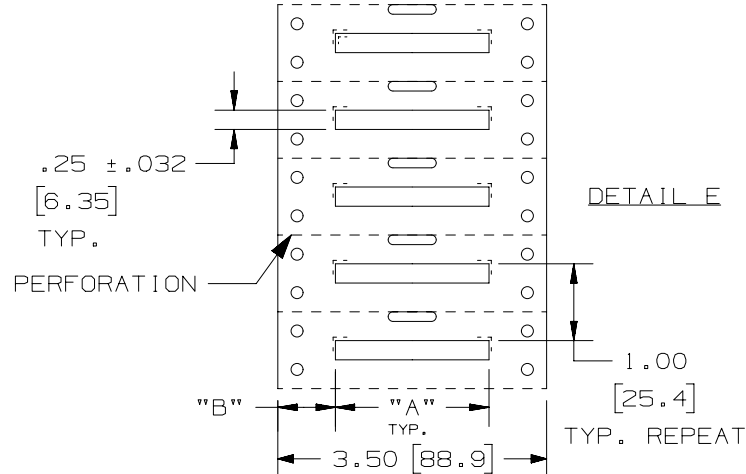
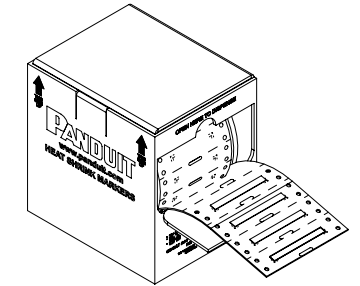

STYLE B

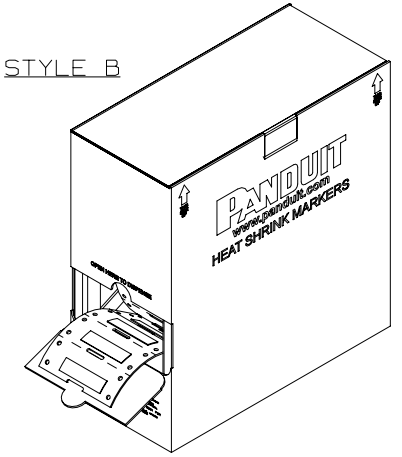

NOTE:  
1. DIMENSIONS IN [ ] ARE IN MILLIMETERS.

PART NUMBER	SEE DETAIL	"A" +/- .062	"B"	MARKER ACROSS	TUBING COLOR	SEE STYLE	MARKERS PER ROLL
H050X025H1T	A	0.50 [ 12.70 ]	.75 [ 19.1 ]	4	WHITE	A	2000
H075X025H1T	B	0.75 [ 19.05 ]	1.00 [ 25.4 ]	2			1000
H100X025H1T	C	1.00 [ 25.40 ]	.75 [ 19.1 ]	2			1000
H150X025H1T	D	1.50 [ 38.10 ]	1.00 [ 25.4 ]	1	YELLOW	A	500
H200X025H1T	E	2.00 [ 50.80 ]	.75 [ 19.1 ]	1			500
H050X025H2T	A	0.50 [ 12.70 ]	.75 [ 19.1 ]	4			2000
H075X025H2T	B	0.75 [ 19.05 ]	1.00 [ 25.4 ]	2	BLACK	A	1000
H100X025H2T	C	1.00 [ 25.40 ]	.75 [ 19.1 ]	2			1000
H150X025H2T	D	1.50 [ 38.10 ]	1.00 [ 25.4 ]	1			500
H200X025H2T	E	2.00 [ 50.80 ]	.75 [ 19.1 ]	1	RED	A	500
H050X025H3T	A	0.50 [ 12.70 ]	.75 [ 19.1 ]	4			2000
H075X025H3T	B	0.75 [ 19.05 ]	1.00 [ 25.4 ]	2			1000
H100X025H3T	C	1.00 [ 25.40 ]	.75 [ 19.1 ]	2	WHITE	B	1000
H150X025H3T	D	1.50 [ 38.10 ]	1.00 [ 25.4 ]	1			500
H200X025H3T	E	2.00 [ 50.80 ]	.75 [ 19.1 ]	1			500
H050X025H1T-B	A	0.50 [ 12.70 ]	.75 [ 19.1 ]	4			10000
H075X025H1T-B	B	0.75 [ 19.05 ]	1.00 [ 25.4 ]	2			5000
H100X025H1T-B	C	1.00 [ 25.40 ]	.75 [ 19.1 ]	2			5000
H150X025H1T-B	D	1.50 [ 38.10 ]	1.00 [ 25.4 ]	1			2500
H200X025H1T-B	E	2.00 [ 50.80 ]	.75 [ 19.1 ]	1			2500

9

REV	DATE	BY	CHK	APR	DESCRIPTION	ECN
9	4/28/15	RVU	SEWH	JHAC	ADD NEW COLUMN OF MARKERS PER ROLL.	GAECN02781
8	1/19/15	RVU	SEWH	MSAD	REVISED TO CURRENT PANDUIT LOGO.	GAECN02539
7	4/12/12	RVU			REVISED H150 PARTS TO SHOW ALL MARKERS ARE ONLY 1.5" LONG.	6731
6	5/21/09	RVU			+/- .12, +/- .062, +/- .020 WAS +/- .03, +/- .032, +/- .010. HT: .25 +/- .032 WAS .250. MAT'L, HSK TUBING GMUHS31, 3.5 WIDE LINER WAS GMUHS. ADD "A" +/- .062. ADD STYLE B VIEW FOR BULK BOX. UPDATE VIEWS.	5593

TITLE					
<b>H***X025H*T</b> OPTIMUM COMPUTER PRINTABLE MIL. SPEC. HEAT SHRINK MARKERS CUSTOMER DRAWING					
ITEM REVISION NAME			100923NG/11		
DATASET FILE NAME			100923NG_DC_C10432/11K		
UNLESS OTHERWISE SPECIFIED, DIMENSIONAL TOLERANCES ARE: IN [ mm ]					
.x ± .12 [ 3.05 ]		.xxx ± .020 [ 0.508 ]			
.xx ± .062 [ 1.57 ]		ANGLES ±			
THIRD ANGLE PROJECTION					
DRAWN BY			SCALE		
RVU			NTS		
DATE			SIZE		
8/1/06			A		
CHK			DRAWING NUMBER:		
MSAD			C10432		
SHT 1 OF 1					

## X-ON Electronics

Largest Supplier of Electrical and Electronic Components

*Click to view similar products for [Wire Labels & Markers](#) category:*

*Click to view products by [Panduit](#) manufacturer:*

Other Similar products are found below :

[89078GBEST](#) [89082GBESR](#) [89082GBEST](#) [PCL025-4](#) [5761-2SF](#) [58400](#) [586R734H02](#) [M1.040.0000.6](#) [CRS-CM5M](#) [CRS-M18M](#) [CS1836-000](#) [CS8626-000](#) [CU6337-000](#) [CU6342-000](#) [CU6343-000](#) [CWD01-0](#) [CWD012-0](#) [CWD012-7](#) [CWD015-3](#) [CWD015-7](#) [CWD02-0](#) [CWD02-3](#) [CWD02-4](#) [CWD02-6](#) [CWD02-8](#) [CWD02-A](#) [CWD02-D](#) [CWD02-H](#) [CWD02-K](#) [CWD02-L](#) [CWD02-M](#) [CWD02-P](#) [CWD02-Q](#) [CWD02-R](#) [CWD02-U](#) [CWD02-W](#) [CWD02-Y](#) [CWD03-+](#) [CWD03-0](#) [CWD03-P](#) [CWD06-0](#) [CWD06-8](#) [CWD06-9](#) [CWD06-L](#) [CWD06-N](#) [CWD09-0](#) [CWD09-5](#) [CWD09-7](#) [6806810001](#) [CZ2857-000](#)