

## GRIPPER REPLACEMENT KIT FOR PPTS INSTALLATION INSTRUCTIONS

© Panduit Corp. 2016

The KPTSG Gripper Replacement Kit replaces the current gripper in the event of reduced performance or excessive wear caused by extended usage. Follow the step-by-step instructions below.

### CONTENTS:

<u>ITEM</u>	<u>QTY.</u>	<u>DESCRIPTION</u>
22	1	Gripper Housing Assembly
14	1	Screw
	1	Removable Threadlocker (for MSDS sheet, see <a href="http://www.loctite.com">www.loctite.com</a> )
	1	PVC Tubing

### REPLACING THE GRIPPER HOUSING ASSEMBLY *(Refer to Customer Repair Drawing, WB23312D01 which is on reverse side.)*



**WARNING:** Always disconnect the air source from the tool before disassembly of the tool. **Never** connect the air source to the tool or actuate the tool until the tool is fully reassembled.

1. Remove and retain the screw from the back end of the tool. Reduce tension on the tool by flipping the selector knob to the MIN setting and turning the selector knob counterclockwise until the knob loosens.
2. Place the tool on a table with the right side of the tool face down and the nose end to the left. Remove the three (3) housing screws using a Phillips screwdriver, and lift off the housing cover.
3. Remove the lever arm pivot pin and the trigger link pin. Carefully lift out the lever arm and the cylinder/link plate assembly.
4. Slide the PVC tubing (included) over the gripper housing assembly and onto the cylinder shaft. Carefully grip the cylinder shaft at the tubing protected area in a brass jaw vise (to prevent damage to the shaft surface). Grip the shaft as close to the gripper housing assembly as possible. Unscrew the gripper housing assembly using a 5/16" open-end wrench.
5. Apply Removable Threadlocker (included) on the new gripper housing assembly threads. Tighten the new gripper assembly on the cylinder shaft and remove the assembly from the vise. Remove the PVC tubing from the cylinder shaft and discard the tubing.
6. Carefully position the cylinder/link plate assembly in the tool. Position the trigger link and install the trigger link pin. Position the lever arm and install the lever arm pivot pin. Position the trigger and replace the housing cover. Fasten cover using the three (3) housing screws and tighten until snug.
7. Replace the screw at the back end of the tool. Readjust tool tension to the desired setting.

E-mail:  
[techsupport@panduit.com](mailto:techsupport@panduit.com)

**PANDUIT**  
[www.panduit.com](http://www.panduit.com)

Technical Support:  
1-800-777-3300

(K)\*\* OPTIONAL LEVER ARM, WB24326C01 IS AVAILABLE NOT TO EJECT THE CUT TIE AT THE END OF THE STROKE

ITEM	QTY	PART NUMBER	DESCRIPTION
(H)	1	OWB23330B01	SERVICE SUB-ASSY, HOUSING PPTS
(J)	1	OWB23329B01	SERVICE SUB-ASSY, COVER PPTS
(D)	1	PTS-04782A-PW	HOOK
4	1	*	ASM., CYLINDER
5	1	PTS-04771A-PX	STRIP, BEARING
6	1	WB24126B01	ASM., TENSION BLOCK
7			
8	1	WBO7683C01	TRIGGER
9	1	**WB16435B02	ARM, LEVER
10	1	OWB16203D01	GUARD, BLADE
11	1	+	BLADE
12	3	+	SCREW, BLADE GUARD
13			
(N)	1	OWB23158A01	SCREW, PHPNHD #4X.50 LG
15			
16			
17			
18	3	WB23157A01	SCREW, COVER
19	1	WB23209A01	PIN, DOWEL CAM
20	1	PTS-07652A-PG	PIN, TRIGGER LINK PIVOT
21	1	WAO4729A01	PIN, LEVER ARM PIVOT
22	1	□	ASM., GRIPPER
23	1	WAO4965B02	ASM., LINK PLATE
24	1	WBO4963B01	ASM., INT/EXT HOSE
(E)	1	*	LINK, TRIGGER
26	2	CAT-05353A-PC	GASKET, NYLON
(B)	1	*	O-RING
28			
29	1	WBO4947B01	ASM., EXTERNAL HOSE

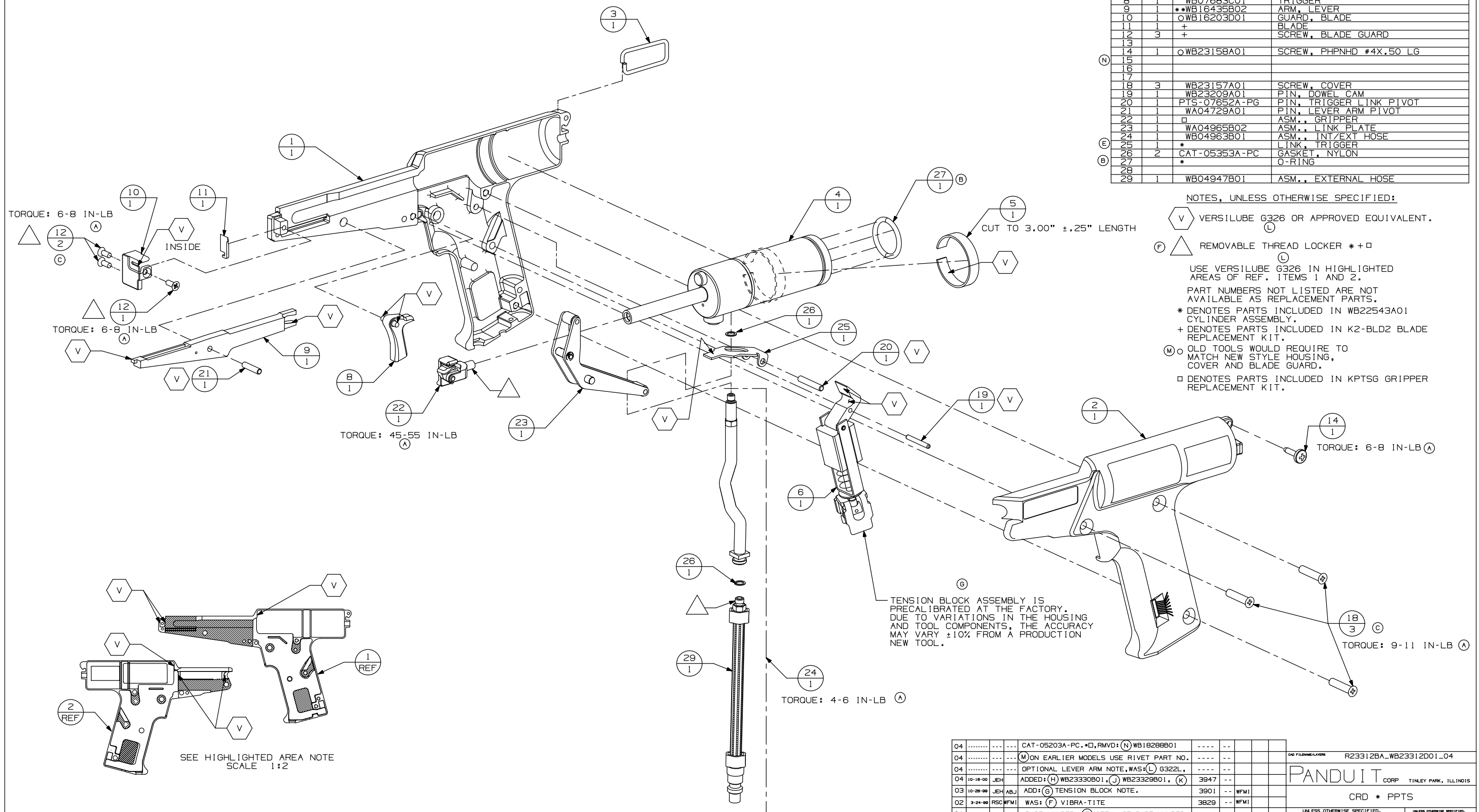

NOTES, UNLESS OTHERWISE SPECIFIED:

- (V) VERSILUBE G326 OR APPROVED EQUIVALENT.
- (L) REMOVABLE THREAD LOCKER \* + □
- USE VERSILUBE G326 IN HIGHLIGHTED AREAS OF REF. ITEMS 1 AND 2.
- PART NUMBERS NOT LISTED ARE NOT AVAILABLE AS REPLACEMENT PARTS.
- \* DENOTES PARTS INCLUDED IN WB22543A01 CYLINDER ASSEMBLY.
- + DENOTES PARTS INCLUDED IN K2-BLD2 BLADE REPLACEMENT KIT.
- (M) OLD TOOLS WOULD REQUIRE TO MATCH NEW STYLE HOUSING, COVER AND BLADE GUARD.
- DENOTES PARTS INCLUDED IN KPTSG GRIPPER REPLACEMENT KIT.

04	-----	---	CAT-05203A-PC, *□, RMVD: (N) WB18288B01	----	--															
04	-----	---	(M) ON EARLIER MODELS USE RIVET PART NO.	----	--															
04	-----	---	OPTIONAL LEVER ARM NOTE, WAS: (L) G322L,	----	--															
04	10-18-00	JEH	ADDED: (H) WB23330B01, (J) WB23329B01, (K)	3947	--															
03	10-28-98	JEH	ADD: (G) TENSION BLOCK NOTE.	3901	--	WFM1														
02	3-24-98	RSC	WAS: (F) VIBRA-TITE	3829	--	WFM1														
01	-----	---	PART NUMBER (E) ITEM #25 PART NUMBER	-----	----															
01	-----	---	WAS: (C) QTY 1; REM'D: (D) ITEM #4	-----	----															
01	2-13-97	RSC	ADD: (A) TORQUE SPECS (B) ITEM #27;	3684	--	JFL														
00	8-3-98	LZ	RELSD, REPLCS, WB19973D01	3684	--	JFL														
REV	DATE	BY	CHK	DESCRIPTION	ECN	-	R	CUST	SLP	GMH										

UNLESS OTHERWISE SPECIFIED, DIMENSIONAL TOLERANCES ARE:  
 (.XX) ± .01  
 (.XXX) ± .005  
 ANGLE ± .5°

UNLESS OTHERWISE SPECIFIED, ALL DIMENSIONS ARE GIVEN IN INCHES, THIRD ANGLE PROJECTION.  
 SCALE 1:1

DRAWING NO. WB23312D01

PANDUIT CORP TINLEY PARK, ILLINOIS

CRD \* PPTS

## X-ON Electronics

Largest Supplier of Electrical and Electronic Components

*Click to view similar products for [Other Tools](#) category:*

*Click to view products by [Panduit](#) manufacturer:*

Other Similar products are found below :

[CR-0AFL4--332K](#) [568681-1](#) [5800-0090](#) [58061-1](#) [59065-5](#) [59085](#) [00-8273-RDPP](#) [00-8729-WHPP](#) [593033](#) [593072](#) [593564100](#) [593575](#)  
[593593](#) [011349-000](#) [CRCW08052740FRT1](#) [LUC-012S070DSM](#) [LUC-018S070DSP](#) [LUC-024S105DSP](#) [599-2021-3-NME](#) [599-JJ-2021-03](#)  
[00-5080-YWPP](#) [00-9089-RDPP](#) [00-9300-RDPP](#) [CRCW2010331JR02](#) [601-JJ-06](#) [601-SPB](#) [601YSY](#) [602-JJ-03](#) [602SPB](#) [603-JJ-07-FP](#) [603-](#)  
[JJY-04](#) [M15570-25](#) [CRTN1013](#) [CS16](#) [6-1579014-0](#) [CSB3](#) [6203](#) [62200-5709](#) [6240-1](#) [M43435](#) [TY 2](#) [SZ 3](#) [FIN B](#) [BLK](#) [M-5Z](#) [M6816](#) [M7298](#)  
[M7456](#) [M7976](#) [660-29ABT1](#) [662508-1](#) [CVHD-950X-93.333](#) [CW104-01X](#) [671-GP-04-KT39-73207](#)