

THIS COPY IS PROVIDED ON A RESTRICTED BASIS AND IS NOT TO BE USED IN ANY WAY DETRIMENTAL TO THE INTERESTS OF PANDUIT CORP.

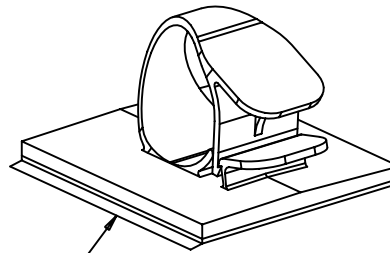
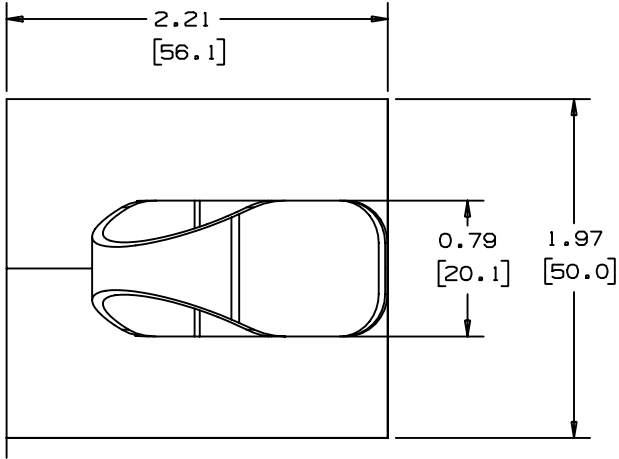

TEAR TAB 3/4 SCALE

PANDUIT PART NUMBER	MAXIMUM CABLE DIA. IN [mm]	WEIGHT LBS. (g) /100PCS
LWC100-A	1.0 [25.4]	2.51 [1140]

NOTES

- SEE CURRENT PRICE SHEET FOR PART NUMBER SUFFIX DESIGNATION, FOR PACKAGE SIZE
- MOUNT IS DESIGNED TO SUPPORT 2.25lbs [1020g] MAX WEIGHT ON A CLEAN, SMOOTH, DRY SURFACE.

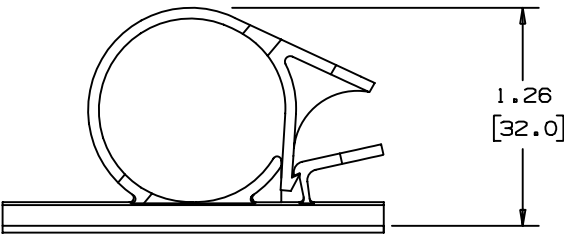

ADHESIVE BACKING: PRESSURE SENSITIVE FOAM 0.04 [1.0] THICK WITH PROTECTIVE LINER TO EXTEND BEYOND THE EDGE FORMING A TEAR TAB.

TO APPLY LATCHING WIRE CLIP:
(APPLY TO A CLEAN GREASE FREE SURFACE)

- REMOVE PROTECTIVE LINER
- PLACE IN DESIRED LOCATION
- APPLY PRESSURE TO THE TOP OF LATCHING WIRE CLIP.

NO WARRANTY, EXPRESSED OR IMPLIED, IS MADE BY PANDUIT WITH RESPECT TO ADHESIVE BOND PERFORMANCE. AMONG OTHER THINGS, THE CONDITIONS UNDER WHICH THESE MOUNTS MAY BE APPLIED, AND/OR THE SURFACE TO WHICH THEY MAY BE APPLIED, ARE BEYOND PANDUIT'S CONTROL.

DIMENSIONS IN BRACKETS ARE METRIC [mm]

CAD FILENAME/LAYERS G00329EZ_PB_LWC100A_02



CORP. TINLEY PARK, ILLINOIS

LWC100-A, LATCHING WIRE CLIP

UNLESS OTHERWISE SPECIFIED, DIMENSIONAL TOLERANCES ARE:
(.X) ±0.05 [1.3] (.XX) ±0.010 [0.25]
(.XX) ±0.02 [0.5] ANGLES ± 5°

UNLESS OTHERWISE SPECIFIED, ALL DIMENSIONS ARE GIVEN IN INCHES, THIRD ANGLE PROJECTION.

REV	DATE	BY	CHK	DESCRIPTION	ECN	R	CUST	SUP
2	01/06/98	CGSM		CHANGED NOTE 3 ON APPLICATION INSTR.	G00329EZ	2		
1	12-15-97	JAD		REVISED DIMENSIONS ADDING METRIC VALUES CORRECTION TO DRAWING NO. WAS G00329EZ	G00329EZ	1		
R	06/18/97	JOS		INITIAL RELEASE	G00329EZ	R		

DRAWN BY JOS
DATE 6/18/97
CHK'D

MAT'L: NYLON 6/6

SCALE NONE

DRAWING NO. GB0329EZ

DWG SIZE A

X-ON Electronics

Largest Supplier of Electrical and Electronic Components

Click to view similar products for [Cable Mounting & Accessories](#) category:

Click to view products by [Panduit](#) manufacturer:

Other Similar products are found below :

[582603-1](#) [009333-000](#) [727844N003](#) [747](#) [809090N001](#) [843188-000](#) [8666](#) [967279N002](#) [DB-11](#) [1300840039](#) [1300900096](#) [1301800416](#)
[1302264450](#) [1300830184](#) [1300830729](#) [1300900039](#) [1301580036](#) [1301850553](#) [1301860939](#) [1302000074](#) [1302261315](#) [1302264431](#)
[1337706-2](#) [APA18-AK](#) [1724](#) [1-787307-1](#) [185491N001](#) [1868](#) [HP-6N](#) [C-202-C](#) [202C221-13-0](#) [CA7308-000](#) [8S23-75FR-CS8184](#) [2684](#) [9648](#)
[3089](#) [988382-000](#) [A72821-000](#) [AA401](#) [173506-000](#) [1823](#) [202C292-13-0](#) [202C302-13-0](#) [2109](#) [300625](#) [3330](#) [3412](#) [356247-1](#) [M9142](#)
[M9143](#)