

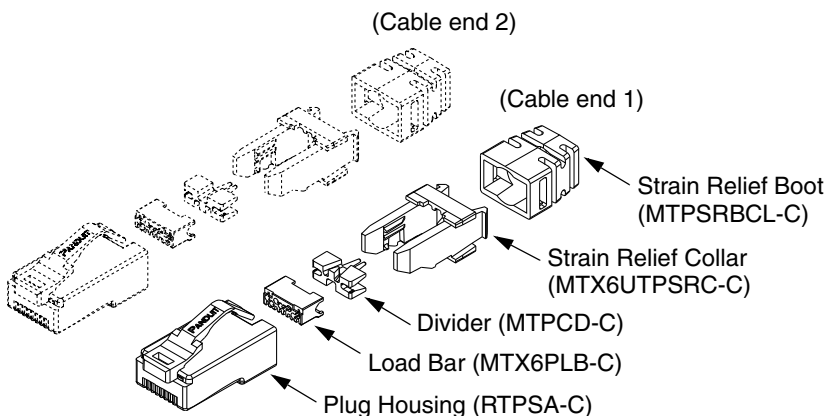

T568B Wiring Scheme



Pin #	8	7	6	5	4	3	2	1
T568B	BRN	BRN/WHT	GRN	BLU/WHT	BLU	GRN/WHT	ORG	ORG/WHT

Specifications

- Cable jacket diameter 0.225-0.250 in.
- 23-24 AWG stranded or solid conductor max. insulated diameter 0.036-0.042 in.
- Panduit recommends T568B wiring scheme for use with cable constructed with the brown pair opposing the orange pair.

Load Bar

Conductor holes and Contact slots

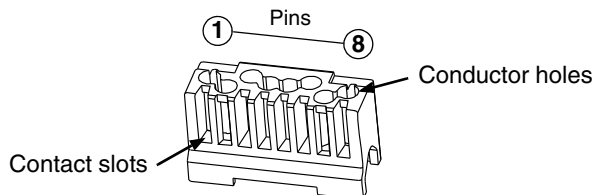

Divider

Conductor slots and "V" channel

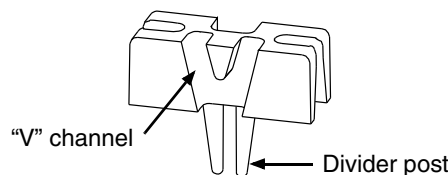

- 1** Thread on boot and collar first!
(Cable ends 1 & 2)

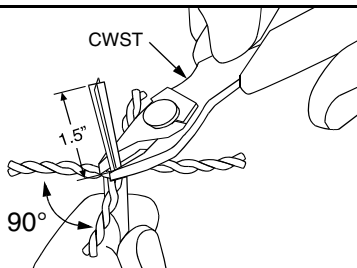
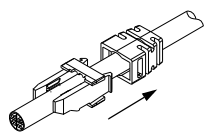

- Thread boot and collar onto cable.
- Remove 1.5" of the outer jacket using wire stripping tool (CWST).
- Fan twisted pairs into respective quadrants. The brown pair should be opposite the orange pair.
- Cut spline flush to fanned pairs using wire snipping tool (CWST).

- 2**

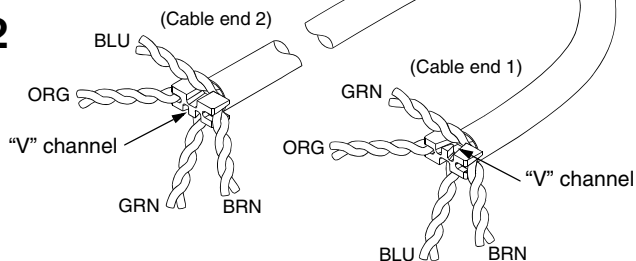

- Align the conductor divider "V" channel with the green pair.
- Insert divider posts into the cable. If the cable has an internal spline, insert divider posts into the brown and orange quadrants of the spline.

- 3**

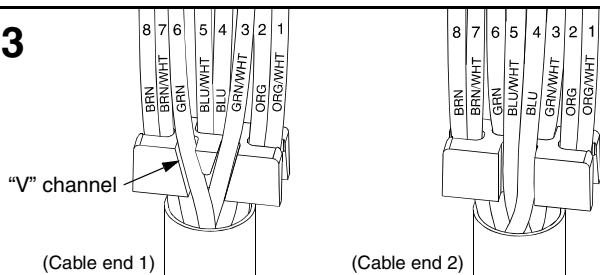

- Arrange conductors to T568B wiring scheme while minimizing untwist.
- Seat conductors into proper divider slots while holding divider flush with cable jacket.

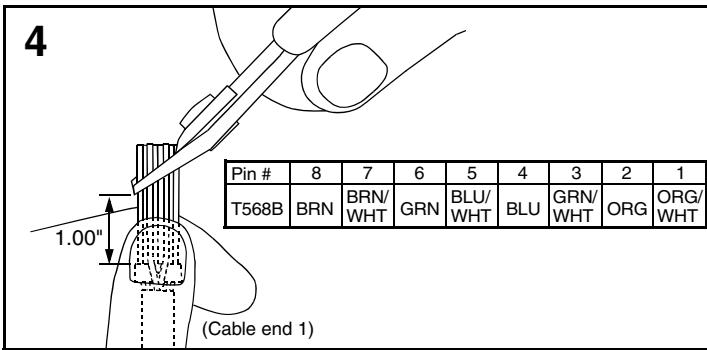

- Straighten and align untwisted conductors using a circular motion while holding conductors in respective divider slots.
- Maintain grip of conductors in T568B wiring scheme.
- Trim conductors on an angle approximately 1.00" from divider leading edge.

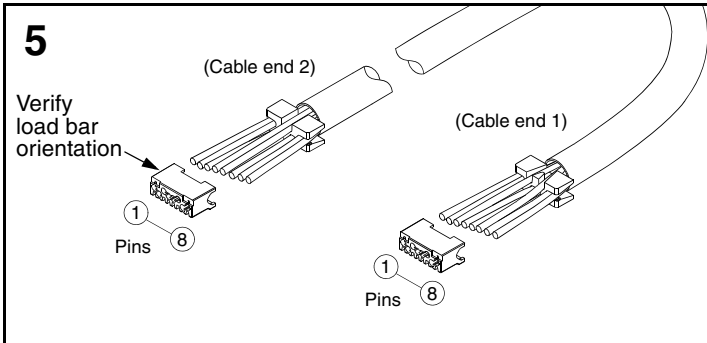

- Orient load bar with contact slots facing downward.

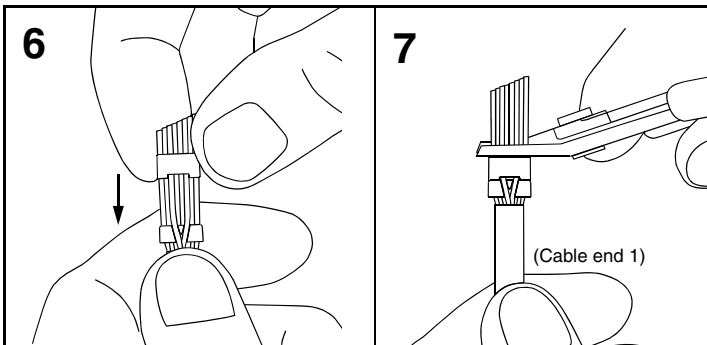

- Guide conductors into load bar holes while holding conductors in the divider.
- Slide load bar towards divider until flush.
- Ensure the divider/load bar is centered and perpendicular to the cable axis.
- Trim conductors flush with load bar face.

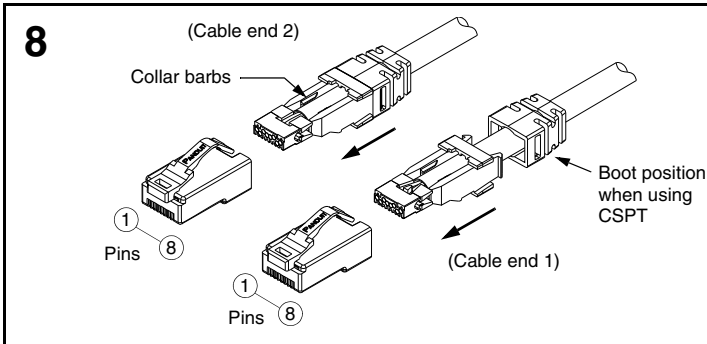

- Hold the load bar and divider stationary while sliding the strain relief collar forward until there is no gap between the collar and divider.
- Confirm the cable jacket extends beyond the collar barbs.
- Align pin #1 of cable sub-assembly (cable, load bar, divider, and strain relief collar) with pin #1 of plug housing.

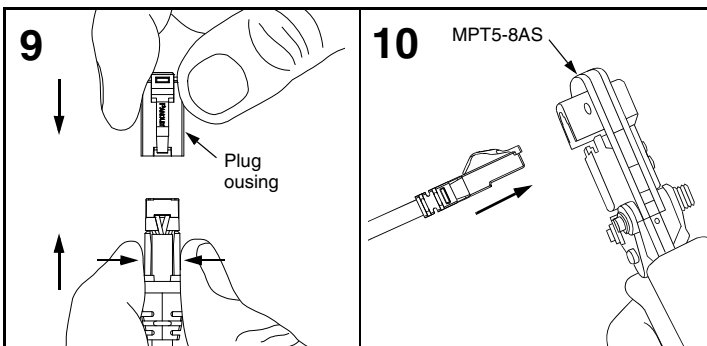

- Grip the strain relief collar and insert cable sub-assembly into the plug housing. (Fig. 9)
- Push sub-assembly into housing until collar locking tabs engage the plug housing pocket. Although not required, TX6 PLUS Plug Assembly Tool (CSPT) is available to facilitate this step.
- Use tool MPT5-8AS to complete plug termination. (Fig. 10)
- Push up boot and engage with collar latches.
- Visually check plug. Assembly is complete.

T568A Wiring Scheme

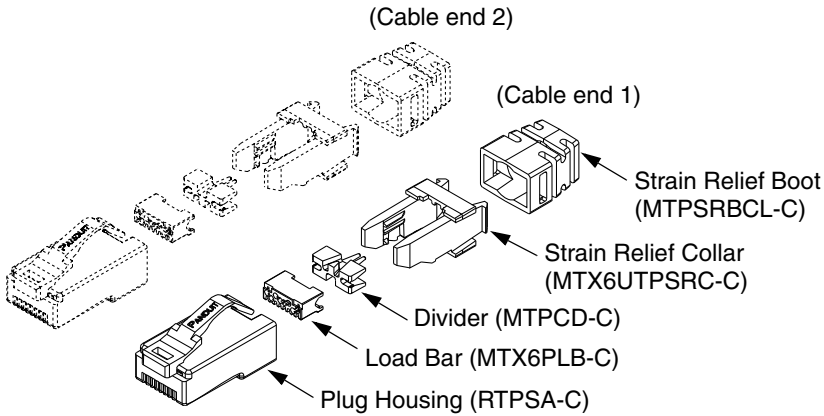

Pin #	8	7	6	5	4	3	2	1
T568A	BRN	BRN/WHT	ORG	BLU/WHT	BLU	ORG/WHT	GRN	GRN/WHT

Specifications

- Cable jacket diameter 0.225-0.250 in.
- 23-24 AWG stranded or solid conductor max. insulated diameter 0.036-0.042 in.
- Panduit recommends T568A wiring scheme for use with cable constructed with the brown pair opposing the green pair.

Load Bar

Conductor holes and Contact slots

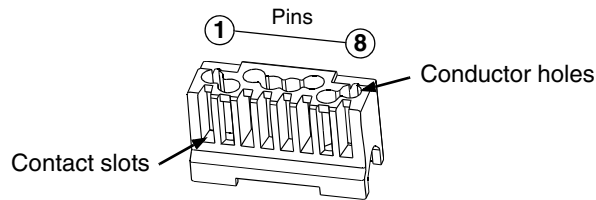

Divider

Conductor slots and "V" channel

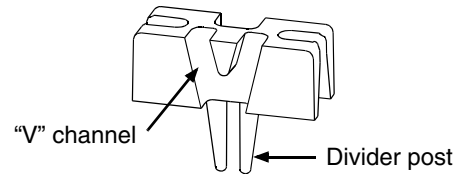

- 1** Thread on boot and collar first!
(Cable ends 1 & 2)

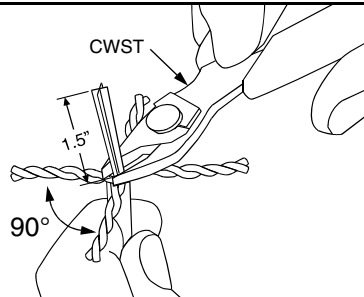
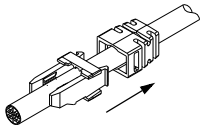

- Thread boot and collar onto cable.
- Remove 1.5" of the outer jacket from the cable end using wire stripping tool (CJAST).
- Fan twisted pairs into respective quadrants. The brown pair should be opposite the green pair.
- When a cable spline (X-shaped filler) is present, cut spline flush to fanned pairs using wire snipping tool (CWST).

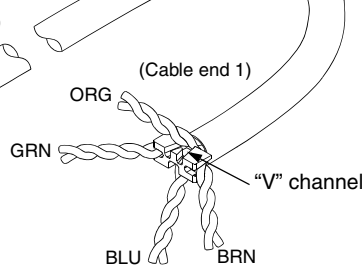
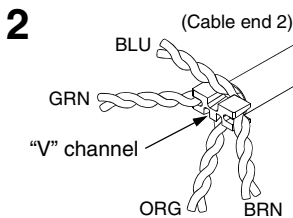

- Align the conductor divider "V" channel with the orange pair.
- Insert divider posts into the cable. If the cable has an internal spline, insert divider posts into the brown and green quadrants of the spline.

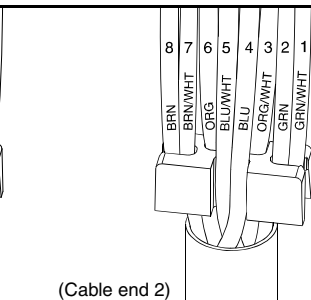
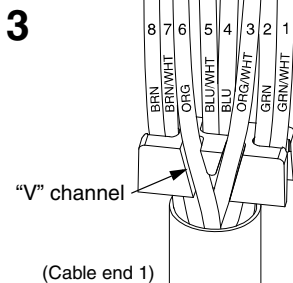

- Arrange conductors to T568A wiring scheme while minimizing untwist.
- Seat conductors into proper divider slots while holding divider flush with cable jacket.

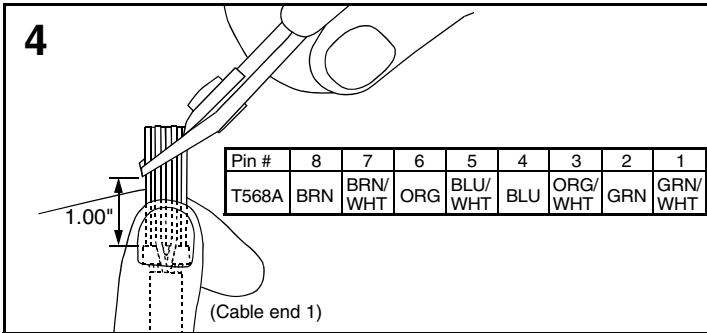

- Straighten and align untwisted conductors using a circular motion while holding conductors in respective divider slots.
- Maintain grip of conductors in T568A wiring scheme.
- Trim conductors on an angle approximately 1.00" from divider leading edge.

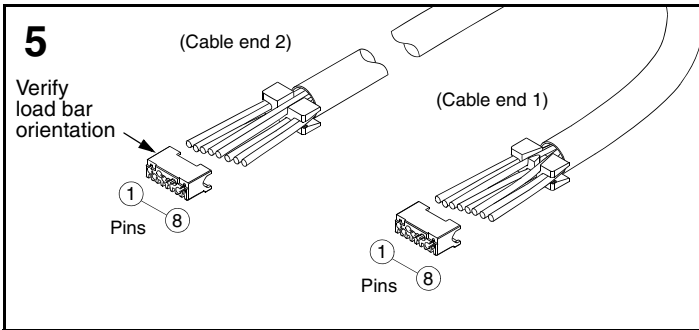

- Orient load bar with contact slots facing downward.

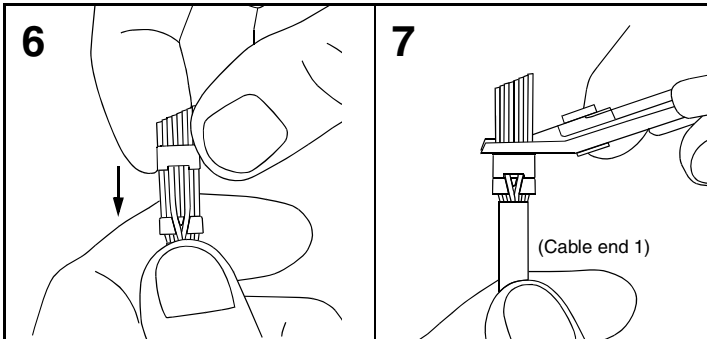

- Guide conductors into load bar holes while holding conductors in the divider.
- Slide load bar towards divider until flush.
- Ensure the divider/load bar is centered and perpendicular to the cable axis.
- Trim conductors flush with load bar face.

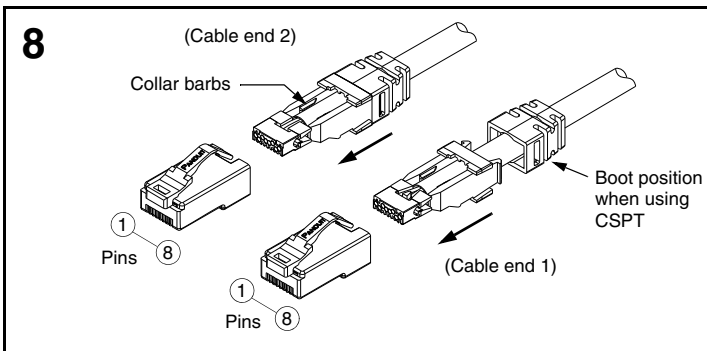

- Hold the load bar and divider stationary while sliding the strain relief collar forward until there is no gap between the collar and divider.
- Confirm the cable jacket extends beyond the collar bars.
- Align pin #1 of cable sub-assembly (cable, load bar, divider, and strain relief collar) with pin #1 of plug housing.

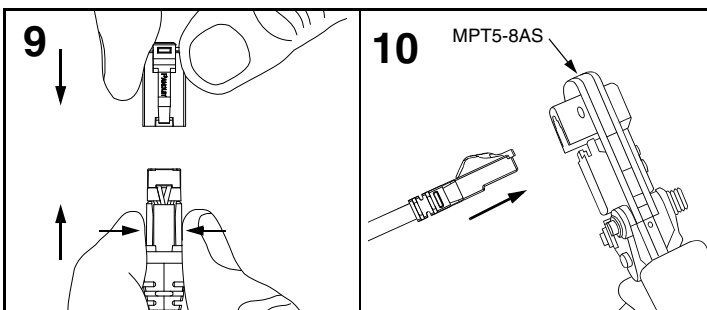

- Grip the strain relief collar and insert cable sub-assembly into the plug housing. (Fig. 9)
- Push sub-assembly into housing until collar locking tabs engage the plug housing pocket. Although not required, TX6 PLUS Plug Assembly Tool (CSPT) is available to facilitate this step.
- Use tool MPT5-8AS to complete plug termination. (Fig. 10)
- Push up boot and engage with collar latches.
- Visually check plug. Assembly is complete.

For Instructions in Local Languages and Technical Support:

www.panduit.com/resources/install_maintain.asp

PANDUIT

www.panduit.com

E-mail: techsupport@panduit.com

Phone: 866-405-6654

X-ON Electronics

Largest Supplier of Electrical and Electronic Components

Click to view similar products for [Cable Mounting & Accessories](#) category:

Click to view products by [Panduit](#) manufacturer:

Other Similar products are found below :

[582603-1](#) [009333-000](#) [727844N003](#) [747](#) [809090N001](#) [843188-000](#) [8666](#) [967279N002](#) [DB-11](#) [1300840039](#) [1300900096](#) [1301800416](#)
[1302264450](#) [1300830184](#) [1300830729](#) [1300900039](#) [1301580036](#) [1301850553](#) [1301860939](#) [1302000074](#) [1302261315](#) [1302264431](#)
[1337706-2](#) [APA18-AK](#) [1724](#) [1-787307-1](#) [185491N001](#) [1868](#) [HP-6N](#) [C-202-C](#) [202C221-13-0](#) [CA7308-000](#) [8S23-75FR-CS8184](#) [2684](#) [9648](#)
[3089](#) [988382-000](#) [A72821-000](#) [AA401](#) [173506-000](#) [1823](#) [202C292-13-0](#) [202C302-13-0](#) [2109](#) [300625](#) [3330](#) [3412](#) [356247-1](#) [M9142](#)
[M9143](#)