

QSFP+ 40Gig™ Copper Cable Assemblies

As virtualization, consolidation, and convergence initiatives continue to grow, so do the demands placed on the physical infrastructure. To meet the needs for faster processing speeds and higher density, Panduit offers QSFP+ Direct Attach Copper Cable Assemblies.

QSFP+ (Quad Small Form factor Pluggable) 40Gig™ cable assemblies provide four channels of 10 Gb/s in one cost effective interface that offers up to four times the density of standard SFP+ 10Gig™ cable assemblies. Panduit QSFP+ are compliant with IEEE802.3ba 40GBASE-CR4 and SFF-8436, while meeting requirements for both QSFP and QSFP+.

End-to-end high speed data transport systems from Panduit deliver enhanced availability, agility, and security. Visit www.panduit.com to learn more about how these solutions help customers manage risk across their physical infrastructure.



Key Features	Benefits
Compliant to IEEE 802.3ba and SFF-8436	Can be used for 40GBASE-CR4 applications and are hot pluggable into QSFP compliant host ports
EEPROM compliant to SFF-8436	Ensures interoperability with 40Gig™ Ethernet
Passive copper cable assembly	Low cost, low power alternative to fiber optics up to 6 meters
High density	Can be used in place of four SFP+ Direct Attach Cables tripling switch port density
Low latency	Can be used for high performance computer clustering and other latency sensitive applications
Robust latching	Easy-to-use latching feature allows high density belly-to-belly installation
Advanced connector design	Reduces crosstalk to meet both 40GBASE-CR4
100% performance tested	Reduces risk of a faulty cord in the field and ensures quicker up time
Variety of lengths	40GBASE-CR4 cable assemblies available 1 to 6 meters (1 meter increments) for design flexibility
Part of the Panduit Unified Physical InfrastructureSM solution	Designed to be integrated with Panduit NetAccess™ Cabinets for improved layout, wire-management, and advanced cooling

Technical Information

- Characteristic impedance: 100 +/- 5 Ω
- Temperature range: -25°C to 80°C (-13°F to 176°F)
- Flame retardant IEC 60332-3-24
- Bend radius: 5 x O.D. single time, 10 x O.D. repeated times
- Withdrawal force from cage: 30 N maximum
- Retention force: 90 N minimum
- Durability: 250 mating cycles minimum
- RoHS compliant

Applications

- Top of Rack (ToR) switch to server
- End of Row (EoR)/Middle of Row(MoR) switch to switch
- Fibre Channel over Ethernet (FCoE)
- 10Gig™ and 40Gig™ Ethernet
- SAS 6G

QSFP+ 40Gig™ Copper Cable Assemblies

Standard Part Number Table

Part Number	Application	Length	Cable Gauge	Nominal Cable O.D.	Cable Jacket	Cable Color
PQSFPXA1MBU	40GBASE-CR4	1m (3.3')	30 AWG	6.1mm (0.24")	PVC	Blue
PQSFPXA2MBU	40GBASE-CR4	2m (6.6')	30 AWG	6.1mm (0.24")	PVC	Blue
PQSFPXA3MBU	40GBASE-CR4	3m (9.8')	30 AWG	6.1mm (0.24")	PVC	Blue
PQSFPXB4MBU	40GBASE-CR4	4m (15.2')	28 AWG	7.1mm (0.28")	PVC	Blue
PQSFPXC5MBU	40GBASE-CR4	5m (16.4')	26 AWG	8.7mm (0.34")	PVC	Blue
PQSFPXD6MBU	40GBASE-CR4	6m (19.7')	24 AWG	9.8mm (0.39")	PVC	Blue

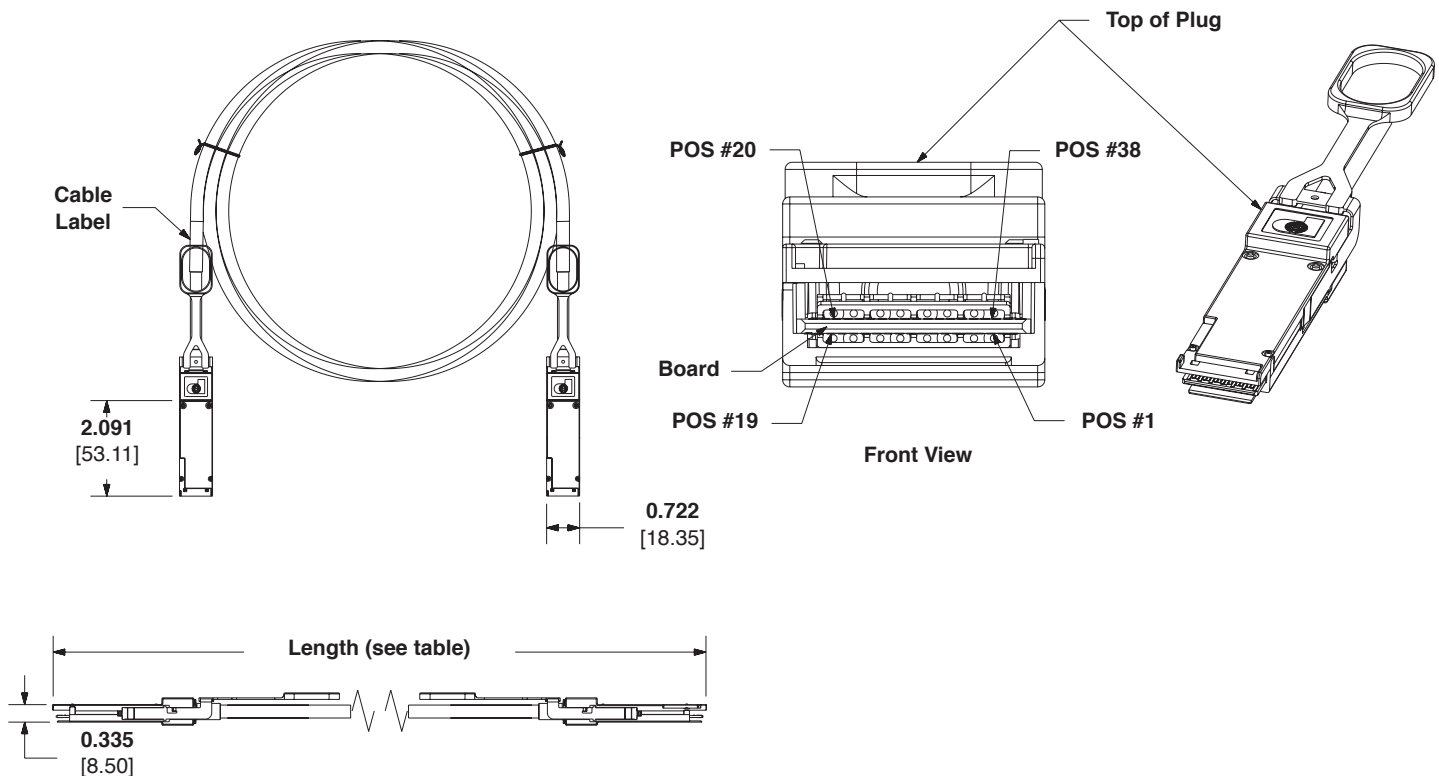

Dimensions are in inches. [Dimensions in brackets are metric].

WORLDWIDE SUBSIDIARIES AND SALES OFFICES

PANDUIT US/CANADA
Phone: 800.777.3300

PANDUIT EUROPE LTD.
London, UK
cs-emea@panduit.com
Phone: 44.20.8601.7200

PANDUIT SINGAPORE PTE. LTD.
Republic of Singapore
cs-ap@panduit.com
Phone: 65.6305.7575

PANDUIT JAPAN
Tokyo, Japan
cs-japan@panduit.com
Phone: 81.3.6863.6000

PANDUIT LATIN AMERICA
Guadalajara, Mexico
cs-la@panduit.com
Phone: 52.33.3777.6000

PANDUIT AUSTRALIA PTY. LTD.
Victoria, Australia
cs-aus@panduit.com
Phone: 61.3.9794.9020

For a copy of Panduit product warranties, log on to www.panduit.com/warranty

For more information

Visit us at www.panduit.com

Contact Customer Service by email: cs@panduit.com
or by phone: 800.777.3300

PANDUIT®

©2017 Panduit Corp.
ALL RIGHTS RESERVED.
Product Bulletin Number **COCB03--WW-ENG**
Replaces SA-COCB28
4/2017

X-ON Electronics

Largest Supplier of Electrical and Electronic Components

Click to view similar products for [Wire Ducting](#) category:

Click to view products by [Panduit](#) manufacturer:

Other Similar products are found below :

[66200A-10](#) [CVED32VEPG](#) [CVED40VEPG](#) [F512D5-5F140Y](#) [F512D5-5F200Y](#) [F512D5-5F26Y](#) [F512D5-5F30Y](#) [F512D5-5F33Y](#) [F512D5-5F34Y](#) [F512D5-5F45Y](#) [F512D5-5F50Y](#) [F512D5-5F54Y](#) [F512D5-5F66Y](#) [F512D5-5F70Y](#) [F512D5-5F75Y](#) [F512D5-5F90Y](#) [F612D5-5F100Y](#) [F612D5-5F130Y](#) [F612D5-5F50Y](#) [F612D5-5F56Y](#) [F612D5-5F58Y](#) [F6L12D5-5F46](#) [F912D5-5F11Y](#) [F912D5-5F170Y](#) [F912D5-5F175Y](#) [F912D5-5F230Y](#) [F912D5-5F300Y](#) [F912D5-5F55Y](#) [F912D5-5F56Y](#) [F912D5-5F63Y](#) [F912D5-5F6Y](#) [F912D5-5F75Y](#) [F912D5-5F85Y](#) [F912D5-5F86Y](#) [F912D5-5F88Y](#) [F912D5-5F96Y](#) [FAP0047WBLMTP](#) [FAP12WBRDRDDLZ](#) [FAP12WDYLYLDLZ](#) [FAP12WEORORDLZ](#) [FAP6WEORORDLZ](#) [FAP6WFDBDBDLZ](#) [FAP8WEORORDLZ](#) [FCE2UWCL](#) [800A-LB](#) [802A-ECSP](#) [802I-ICSP](#) [FJQADH](#) [FJQFXT](#) [PED10](#)