

THIS COPY IS PROVIDED ON A RESTRICTED BASIS AND IS NOT TO BE USED IN ANY WAY DETRIMENTAL TO THE INTERESTS OF PANDUIT CORP.

PART NUMBER	MATERIAL	WIDTH "A"	HEIGHT "B"	TAGS & TIES PER PKG.	LAMINATION SIDE	HEADER	HEADER COLOR	DESCRIPTION	LEGEND COLOR
PST-1	SLCT VINYL	2.00 (50.8)	3.00 (76.2)	10	FRONT ONLY	BLANK	BLANK	BLANK	BLANK
PST-2	SLCT VINYL	3.25 (82.6)	5.75 (146.0)	5	FRONT ONLY	BLANK	BLANK	BLANK	BLANK
PST-3	GMV5 AND SEZ-SNC VINYL	3.00 (76.2)	5.75 (146.0)	5	FRONT ONLY	DANGER	WHITE/RED & BLACK	SEE NOTE 2	BLACK/WHITE
PST-4	GMV5 AND SEZ-SNC VINYL	3.50 (88.9)	5.75 (146.0)	25	FRONT ONLY	BLANK	BLANK	BLANK	BLANK
PST-5	GMV5 AND SEZ-SNC VINYL	3.50 (88.9)	5.75 (146.0)	25	FRONT AND BACK	BLANK	BLANK	BLANK	BLANK
PST-12	GMV5 AND SEZ-SNC VINYL	3.00 (76.2)	5.75 (146.0)	5	FRONT ONLY	BLANK	BLANK	DO NOT THROW SYMBOL (SEE NOTE 3)	BLACK/WHITE

NOTES:
1. MILLIMETER ARE IN ().

NOTE 2

NOTE 3



Front PST-3 Back



Front PST-12 Back

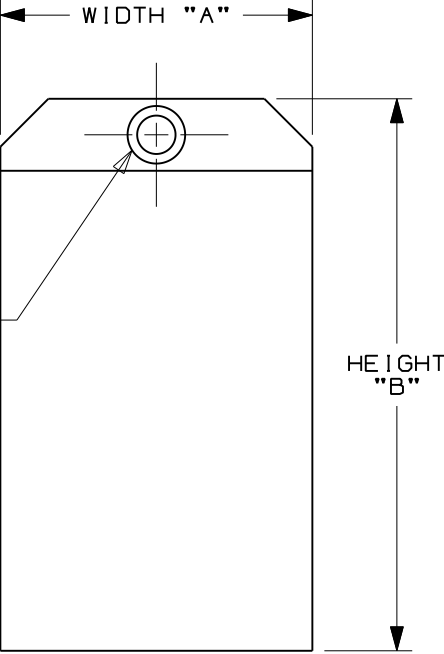
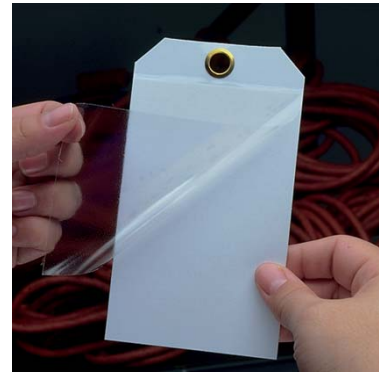

3/8" GROMMET

HEIGHT "B"

CAD FILENAME/LAYERS		I00318LX_DC_C10679/00A	
<h1>PANDUIT</h1> CORP. TINLEY PARK, ILLINOIS			
CUSTOMER DRAWING PST - * INDOOR RIGID VINYL SAFETY TAG CARRIER AND PHOTO TAGS			
UNLESS OTHERWISE SPECIFIED, DIMENSIONAL TOLERANCES ARE: (.X) ± .075 (.XXX) ± .020 (.XX) ± .050 ANGLES ± 5°		UNLESS OTHERWISE SPECIFIED, ALL DIMENSIONS ARE GIVEN IN INCHES, THIRD ANGLE PROJECTION.	
DRAWN BY RVU	MAT'L:	SCALE NTS	
DATE 4/4/08	SEE TABLE	DRAWING NO. C10679	DWG SIZE A
CHK'D			

REV	DATE	BY	CHK	DESCRIPTION	ECN	R	CUST	SUP
0	4/4/08	RVU		DRAWING RELEASE.	5382	R		

X-ON Electronics

Largest Supplier of Electrical and Electronic Components

Click to view similar products for [Labels and Industrial Warning Signs](#) category:

Click to view products by [Panduit](#) manufacturer:

Other Similar products are found below :

[ESSW30-025](#) [FTP-020P0704](#) [QC101](#) [QC105](#) [QCC613](#) [QCC615](#) [132465](#) [142810](#) [15288](#) [15425](#) [18511](#) [HTS795-1](#) [30288](#) [1768021-2](#) [18432](#)
[1878679-3](#) [2-1878614-6](#) [PTL-31-427-YL](#) [30239](#) [QC154](#) [QCC612](#) [30545](#) [35070](#) [WM-15-PK](#) [WM-20-PK](#) [5-1768021-6](#) [06770](#) [11197](#)
[111852](#) [111932](#) [KMT-02513V-9](#) [06742](#) [8-1768039-4](#) [1878983-4](#) [06736](#) [B422 25X85MM](#) [PAXLBK10](#) [LAT-52-361-1](#) [PTL-20-486](#) [PTL-](#)
[38-486](#) [PTLFT-01-425](#) [13903](#) [11237](#) [18389](#) [18341](#) [18603](#) [29904](#) [18519](#) [18524](#) [115110](#)