

2

1

THIS COPY IS PROVIDED ON A RESTRICTED BASIS AND IS NOT TO BE USED IN ANY WAY DETRIMENTAL TO THE INTERESTS OF PANDUIT CORP.

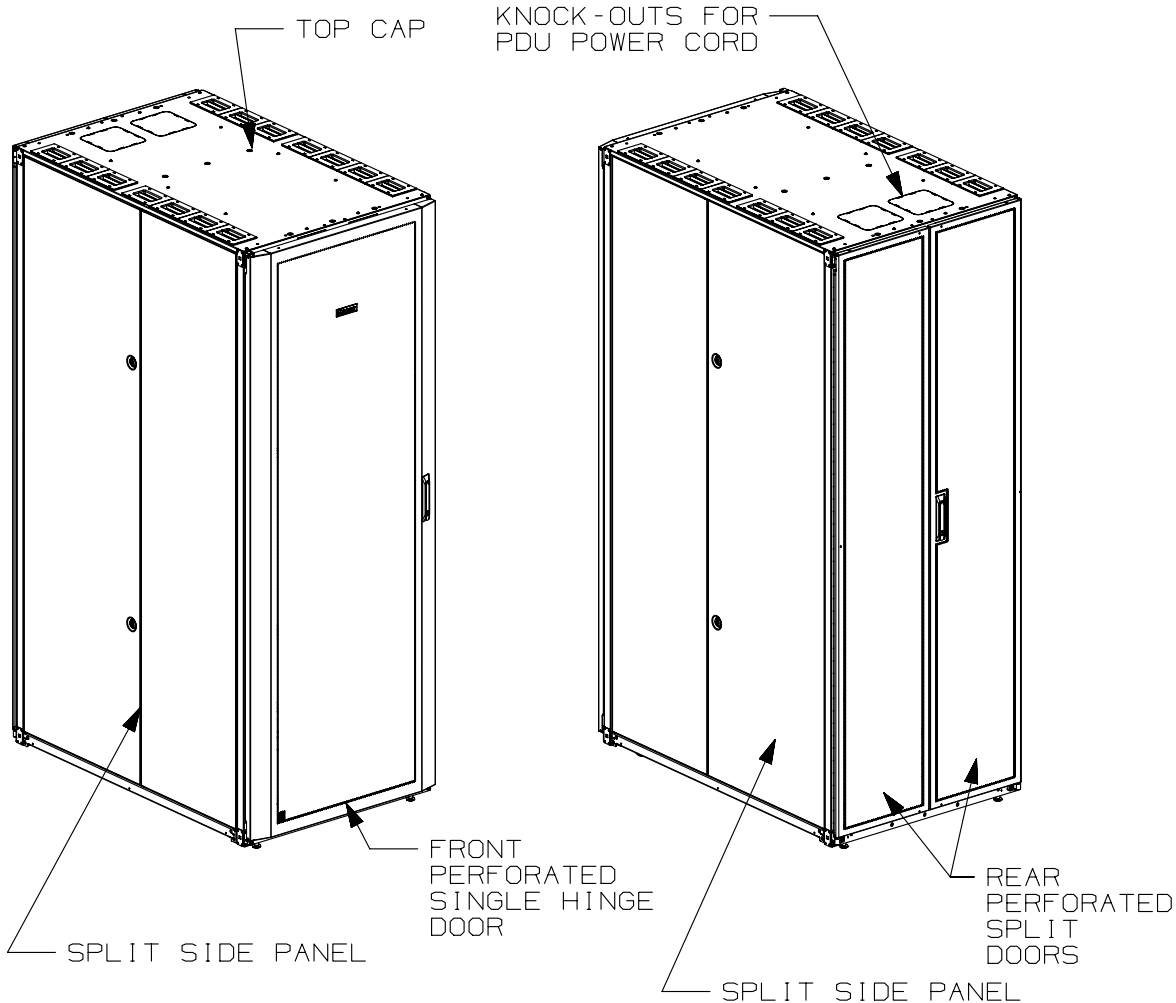

- VISIT OUR ON-LINE CATALOG AT WWW.PANDUIT.COM FOR A LIST OF CURRENT PARTS APPLICABLE FOR USE WITH THIS PRODUCT.
- PRIMARY DIMENSIONS ARE IN MILLIMETERS.
- RAIL ADJUSTMENTS MEASUREMENTS ARE TAKEN FROM THE FRONT FACE OF EACH EQUIPMENT RAIL. INDEPENDENT ADJUSTABLE REAR EQUIPMENT MOUNTING RAILS (E1A) ADJUST FROM 141mm [5.5in] TO 532mm [20.9in] AND FROM 583mm [22.9in] TO 1085mm [42.7in] WITH PDU BRACKETS AND CABLE MANAGEMENT FINGERS IN PLACE.
- CAN BE USED WITH ANY 19" E1A STANDARD COMPONENT IN ADDITION TO ALL PANDUIT HORIZONTAL CABLE MANAGEMENT AND PATCH PANEL PRODUCTS.
- E1A UNIVERSAL STANDARD HOLE PROGRESSION ON EQUIPMENT RAILS
15.88mm [.625in], 15.88mm [.625in], 12.70mm [.5in], 15.88mm [.625in], 15.88mm [.625in], 12.7mm [.5in]...ETC.
- PARTS SUPPLIED:
-BASE CABINET
-FRONT PERFORATED SINGLE HINGE DOOR (SEE CHART ON SHEET 2)
-REAR PERFORATED SPLIT DOOR (SEE CHART ON SHEET 2)
-EQUIPMENT RAILS FRONT & REAR (SEE CHART ON SHEET 2)
-PDU BRACKETS (SEE CHART ON SHEET 2)
-CASTERS (SEE CHART ON SHEET 2)
-INSTRUCTION SHEET
- RACK UNIT SPACING NUMERALS ARE CLEARLY PRINTED ON EQUIPMENT MOUNTING RAILS.
- FULLY BONDED STRUCTURE WHEN ASSEMBLED PER INSTRUCTIONS.
- STATIC LOAD RATING. 1360 Kg (3000 LBS)
- ROLLING LOAD RATING. 1133 Kg (2500 LBS)
- SINGLE POINT GROUND LOCATIONS AT TOP AND BOTTOM OF CABINET.
- ALL CABINET RAILS ARE INSTALLED NUMBERS UP.
- MAXIMUM EQUIPMENT DEPTH, 1111mm [43.75].

| REV | DATE | BY | CHK | APR | DESCRIPTION | ECN |
|-----|----------|------|-----|------|--------------------------------|-------------|
| 02A | 11-14-14 | PBS | ADP | TCN | FLOOR MOUNT DIMENSIONS UPDATED | V09000BX |
| 00B | 5-21-13 | MDCA | JDW | JDWE | REVISED CHART | 12V305TM-DC |
| 00A | 8-29-12 | TWV | JDW | PBD | RELEASED TO PRODUCTION | 12V305TM-DC |

| | | | | | | | |
|--------------------|--|--|---------|--|-----|----------------------------------------------------------------------------|------|
| TITLE | | | | | | NET-ACCESS S-TYPE CABINET 800mm WIDE X 1200mm DEEP FAMILY | |
| | | | | | | CONTROL DRAWING | |
| ITEM REVISION NAME | | | | | | 12V305TM/02 | |
| DATASET FILE NAME | | | | | | 12V305TM_DC/02A | |
| MATERIAL: | | | | | | PANDUIT | |
| | | | | | | N/A | |
| DRAWING NUMBER: | | | | | | 12V305TM-DC | |
| DRAWN BY | | | DATE | | CHK | SCALE | SIZE |
| T WV | | | 8-29-12 | | JDW | NONE | A |

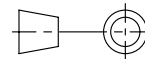

THIRD ANGLE PROJECTION

D10100DA/16

2

1

THIS COPY IS PROVIDED ON A RESTRICTED BASIS AND IS NOT TO BE USED IN ANY WAY DETRIMENTAL TO THE INTERESTS OF PANDUIT CORP.

| PART NO. | DESCRIPTION | SINGLE HINGE FRONT DOOR | SPLIT REAR DOOR | SPLIT SIDE PANEL | FRONT CAGE NUT E-RAIL | REAR CAGE NUT FINGER MGMT E-RAIL | REAR CAGE NUT VERTICAL PATCH E-RAIL | STANDARD PDU BRACKETS | CASTERS | CABLE MGMT FINGERS | VERTICAL PATCHING | CABINET WEIGHT FULLY UNPACKAGED | CABINET WEIGHT SHIPPING WEIGHT |
|----------|------------------------------------------------------|-------------------------|-----------------|------------------|-----------------------|----------------------------------|-------------------------------------|-----------------------|---------|--------------------|-------------------|---------------------------------|--------------------------------|
| S8222* | NET-ACCESS S-TYPE CABINET 800mm X 42RU X 1200mm DEEP | 01 | 01 | 02 | 02 | 02 | 00 | 02 | 04 | 00 | 00 | 152 Kg/EACH 335 LBS/EACH | 172 Kg/EACH 380 LBS/EACH |
| S8522* | NET-ACCESS S-TYPE CABINET 800mm X 45RU X 1200mm DEEP | 01 | 01 | 02 | 02 | 02 | 00 | 02 | 04 | 00 | 00 | 165 Kg/EACH 365 LBS/EACH | 186 Kg/EACH 410 LBS/EACH |
| S8822* | NET-ACCESS S-TYPE CABINET 800mm X 48RU X 1200mm DEEP | 01 | 01 | 02 | 02 | 02 | 00 | 02 | 04 | 00 | 00 | 179 Kg/EACH 395 LBS/EACH | 199 Kg/EACH 440 LBS/EACH |
| S8229* | NET-ACCESS S-TYPE CABINET 800mm X 42RU X 1200mm DEEP | 01 | 01 | 00 | 02 | 02 | 00 | 02 | 04 | 00 | 00 | 112 Kg/EACH 248 LBS/EACH | 133 Kg/EACH 293 LBS/EACH |
| S8529* | NET-ACCESS S-TYPE CABINET 800mm X 45RU X 1200mm DEEP | 01 | 01 | 00 | 02 | 02 | 00 | 02 | 04 | 00 | 00 | 119 Kg/EACH 263 LBS/EACH | 140 Kg/EACH 308 LBS/EACH |
| S8829* | NET-ACCESS S-TYPE CABINET 800mm X 48RU X 1200mm DEEP | 01 | 01 | 00 | 02 | 02 | 00 | 02 | 04 | 00 | 00 | 126 Kg/EACH 278 LBS/EACH | 146 Kg/EACH 323 LBS/EACH |
| S8222*F | NET-ACCESS S-TYPE CABINET 800mm X 42RU X 1200mm DEEP | 01 | 01 | 02 | 02 | 02 | 00 | 02 | 04 | 01 | 00 | 153 Kg/EACH 337 LBS/EACH | 173 Kg/EACH 382 LBS/EACH |
| S8522*F | NET-ACCESS S-TYPE CABINET 800mm X 45RU X 1200mm DEEP | 01 | 01 | 02 | 02 | 02 | 00 | 02 | 04 | 01 | 00 | 166 Kg/EACH 367 LBS/EACH | 187 Kg/EACH 412 LBS/EACH |
| S8822*F | NET-ACCESS S-TYPE CABINET 800mm X 48RU X 1200mm DEEP | 01 | 01 | 02 | 02 | 02 | 00 | 02 | 04 | 01 | 00 | 180 Kg/EACH 397 LBS/EACH | 200 Kg/EACH 442 LBS/EACH |
| S8229*F | NET-ACCESS S-TYPE CABINET 800mm X 42RU X 1200mm DEEP | 01 | 01 | 00 | 02 | 02 | 00 | 02 | 04 | 01 | 00 | 113 Kg/EACH 250 LBS/EACH | 134 Kg/EACH 295 LBS/EACH |
| S8529*F | NET-ACCESS S-TYPE CABINET 800mm X 45RU X 1200mm DEEP | 01 | 01 | 00 | 02 | 02 | 00 | 02 | 04 | 01 | 00 | 120 Kg/EACH 265 LBS/EACH | 141 Kg/EACH 310 LBS/EACH |
| S8829*F | NET-ACCESS S-TYPE CABINET 800mm X 48RU X 1200mm DEEP | 01 | 01 | 00 | 02 | 02 | 00 | 02 | 04 | 01 | 00 | 127 Kg/EACH 280 LBS/EACH | 147 Kg/EACH 325 LBS/EACH |
| S8222*S | NET-ACCESS S-TYPE CABINET 800mm X 42RU X 1200mm DEEP | 00 | 00 | 02 | 02 | 02 | 00 | 02 | 04 | 00 | 00 | 127 Kg/EACH 280 LBS/EACH | 147 Kg/EACH 325 LBS/EACH |
| S8522*S | NET-ACCESS S-TYPE CABINET 800mm X 45RU X 1200mm DEEP | 00 | 00 | 02 | 02 | 02 | 00 | 02 | 04 | 00 | 00 | 141 Kg/EACH 310 LBS/EACH | 161 Kg/EACH 355 LBS/EACH |
| S8822*S | NET-ACCESS S-TYPE CABINET 800mm X 48RU X 1200mm DEEP | 00 | 00 | 02 | 02 | 02 | 00 | 02 | 04 | 00 | 00 | 154 Kg/EACH 340 LBS/EACH | 175 Kg/EACH 385 LBS/EACH |
| S8229*S | NET-ACCESS S-TYPE CABINET 800mm X 42RU X 1200mm DEEP | 00 | 00 | 00 | 02 | 02 | 00 | 02 | 04 | 00 | 00 | 87 Kg/EACH 193 LBS/EACH | 108 Kg/EACH 238 LBS/EACH |
| S8529*S | NET-ACCESS S-TYPE CABINET 800mm X 45RU X 1200mm DEEP | 00 | 00 | 00 | 02 | 02 | 00 | 02 | 04 | 00 | 00 | 94 Kg/EACH 208 LBS/EACH | 115 Kg/EACH 253 LBS/EACH |
| S8829*S | NET-ACCESS S-TYPE CABINET 800mm X 48RU X 1200mm DEEP | 00 | 00 | 00 | 02 | 02 | 00 | 02 | 04 | 00 | 00 | 101 Kg/EACH 223 LBS/EACH | 121 Kg/EACH 268 LBS/EACH |

* DENOTES COLOR
 "B" = BLACK
 "W" = WHITE

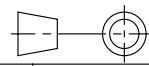
| | | | | | | | | | | | | | |
|-----|----------|------|-----|------|--------------------------------|-------------------------------------------------------------------------------------------------------------------|-----------------|-----------------|--------------------------------------------------------------------------------------------------------------|---------------|------------|--|-----------|
| | | | | | | TITLE NET-ACCESS S-TYPE CABINET 800mm WIDE X 1200mm DEEP FAMILY CONTROL DRAWING | | | | | | | |
| | | | | | | ITEM REVISION NAME 12V305TM/02 | | |  | | | | |
| | | | | | | DATASET FILE NAME 12V305TM_DC/02A | | | | | | | |
| 02A | 11-14-14 | PBS | ADP | TCN | SEE SHEET 1 OF 5 FOR REVISIONS | V09000BX | | | MATERIAL: N/A | | | | |
| 00B | 5-21-13 | MDCA | JDW | JDWE | SEE SHEET 1 OF 5 FOR REVISIONS | 12V305TM-DC | | | DRAWING NUMBER: 12V305TM-DC | | | | |
| 00A | 8-29-12 | TWV | JDW | PBD | SEE SHEET 1 OF 5 FOR REVISIONS | 12V305TM-DC | | |  THIRD ANGLE PROJECTION | | | | |
| REV | DATE | BY | CHK | APR | DESCRIPTION | ECN | DRAWN BY TWV | DATE 8-29-12 | CHK JDW | SCALE NONE | SHT 2 OF 5 | | SIZE A |

D10100DA/16

THIS COPY IS PROVIDED ON A RESTRICTED BASIS AND IS NOT TO BE USED IN ANY WAY DETRIMENTAL TO THE INTERESTS OF PANDUIT CORP.

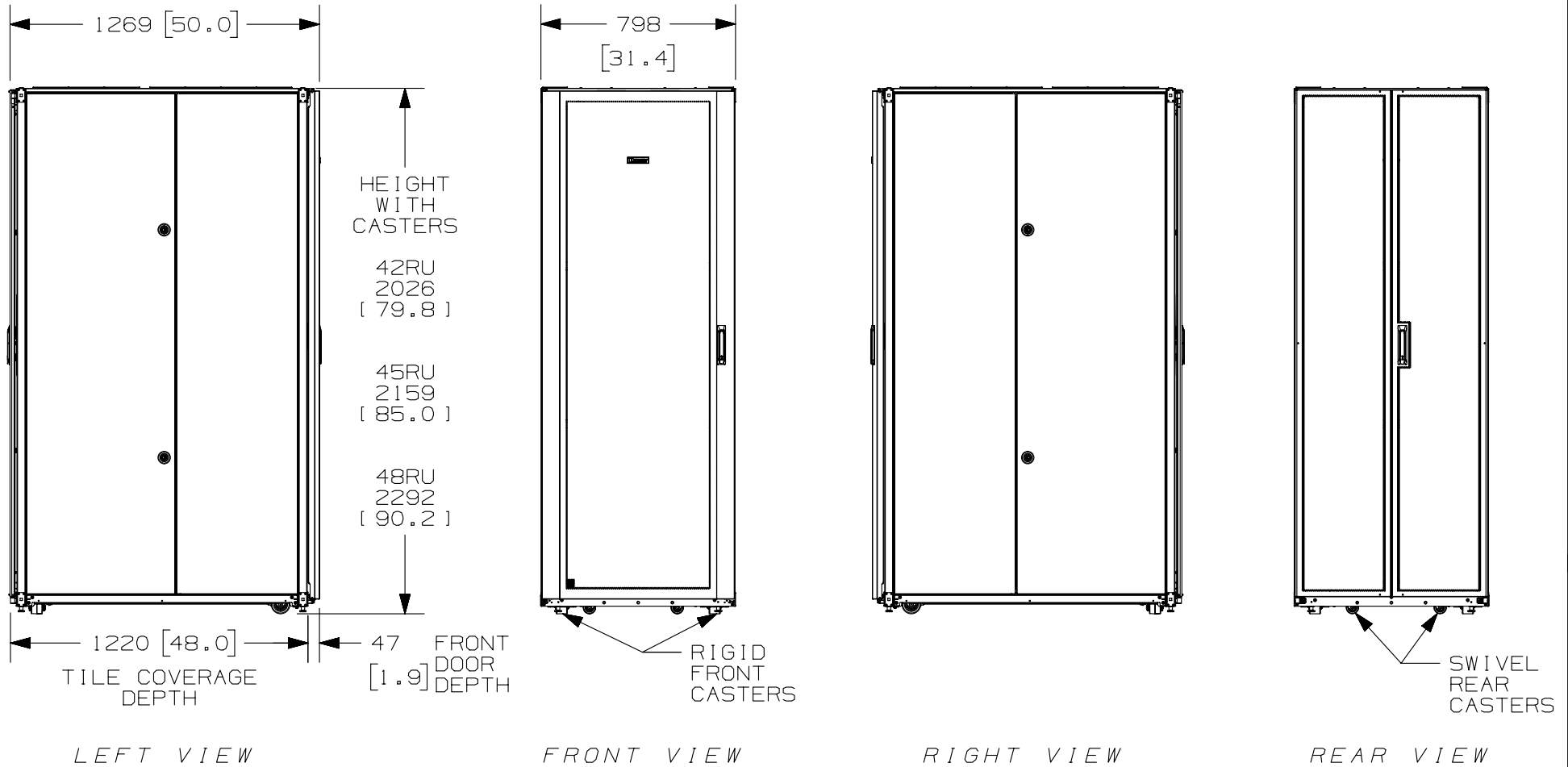

| REV | DATE | BY | CHK | APR | DESCRIPTION | ECN |
|-----|----------|------|-----|------|--------------------------------|-------------|
| 02A | 11-14-14 | PBS | ADP | TCN | SEE SHEET 1 OF 5 FOR REVISIONS | V09000BX |
| 00B | 5-21-13 | MDCA | JDW | JDWE | SEE SHEET 1 OF 5 FOR REVISIONS | 12V305TM-DC |
| 00A | 8-29-12 | TWV | JDW | PBD | SEE SHEET 1 OF 5 FOR REVISIONS | 12V305TM-DC |

| | | | |
|------------------------|--|--------------------------------------------------------------|-----|
| TITLE | | NET-ACCESS S-TYPE CABINET 800mm WIDE X 1200mm DEEP FAMILY | |
| | | CONTROL DRAWING | |
| ITEM REVISION NAME | | 12V305TM/02 | |
| DATASET FILE NAME | | 12V305TM_DC/02A | |
| MATERIAL: | | N/A | |
| DRAWING NUMBER: | | 12V305TM-DC | |
| DRAWN BY | | DATE | CHK |
| T WV | | 8-29-12 | JDW |
| SCALE | | NONE | |
| THIRD ANGLE PROJECTION | | SHT 3 OF 5 | |
| SIZE | | A | |

D10100DA/16

THIS COPY IS PROVIDED ON A RESTRICTED BASIS AND IS NOT TO BE USED IN ANY WAY DETRIMENTAL TO THE INTERESTS OF PANDUIT CORP.

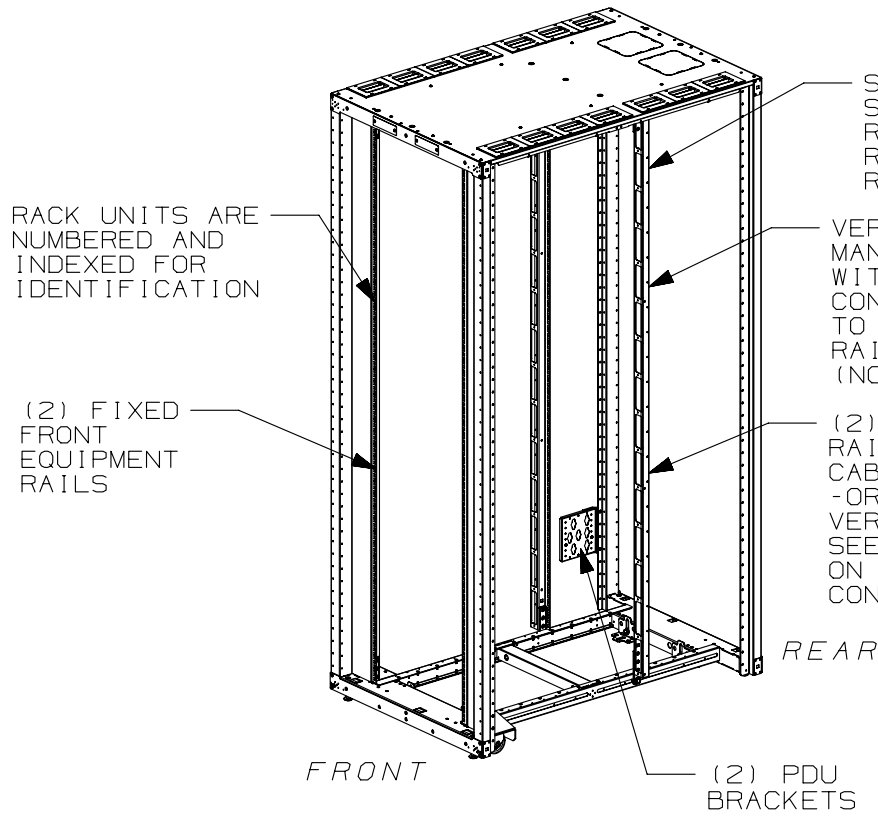

(9) LOCATIONS TAPPED FOR M10 THREADED ROD

(2) 165mm X 165mm [6.5in] [6.5in] KNOCKOUTS FOR PDU POWER CORDS COMPATIBLE W/COOL BOOT P/N: CTGN6X6

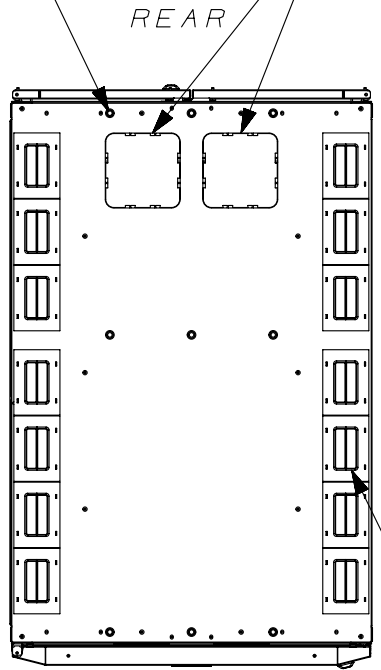

(14) CABLE OPENINGS (83mm X 120mm) [3.26in] [4.7in] WITH BEZELS AND COVERS COMPATIBLE W/ COOL BOOT P/N: CTGN3X5

FRONT DOOR, REAR DOOR, AND SIDE PANELS NOT SHOWN

| REV | DATE | BY | CHK | APR | DESCRIPTION | ECN |
|-----|----------|------|-----|------|--------------------------------|-------------|
| 02A | 11-14-14 | PBS | ADP | TCN | SEE SHEET 1 OF 5 FOR REVISIONS | V09000BX |
| 00B | 5-21-13 | MDCA | JDW | JDWE | SEE SHEET 1 OF 5 FOR REVISIONS | 12V305TM-DC |
| 00A | 8-29-12 | TWV | JDW | PBD | SEE SHEET 1 OF 5 FOR REVISIONS | 12V305TM-DC |

| | | | | |
|--------------------|---------|--------------------------------------------------------------|-------|------|
| TITLE | | NET-ACCESS S-TYPE CABINET 800mm WIDE X 1200mm DEEP FAMILY | | |
| | | CONTROL DRAWING | | |
| ITEM REVISION NAME | | 12V305TM/02 | | |
| DATASET FILE NAME | | 12V305TM_DC/02A | | |
| MATERIAL: | | N/A | | |
| DRAWING NUMBER: | | 12V305TM-DC | | |
| DRAWN BY | DATE | CHK | SCALE | SIZE |
| TWV | 8-29-12 | JDW | NONE | A |

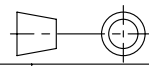

THIRD ANGLE PROJECTION

D10100DA/16

THIS COPY IS PROVIDED ON A RESTRICTED BASIS AND IS NOT TO BE USED IN ANY WAY DETRIMENTAL TO THE INTERESTS OF PANDUIT CORP.

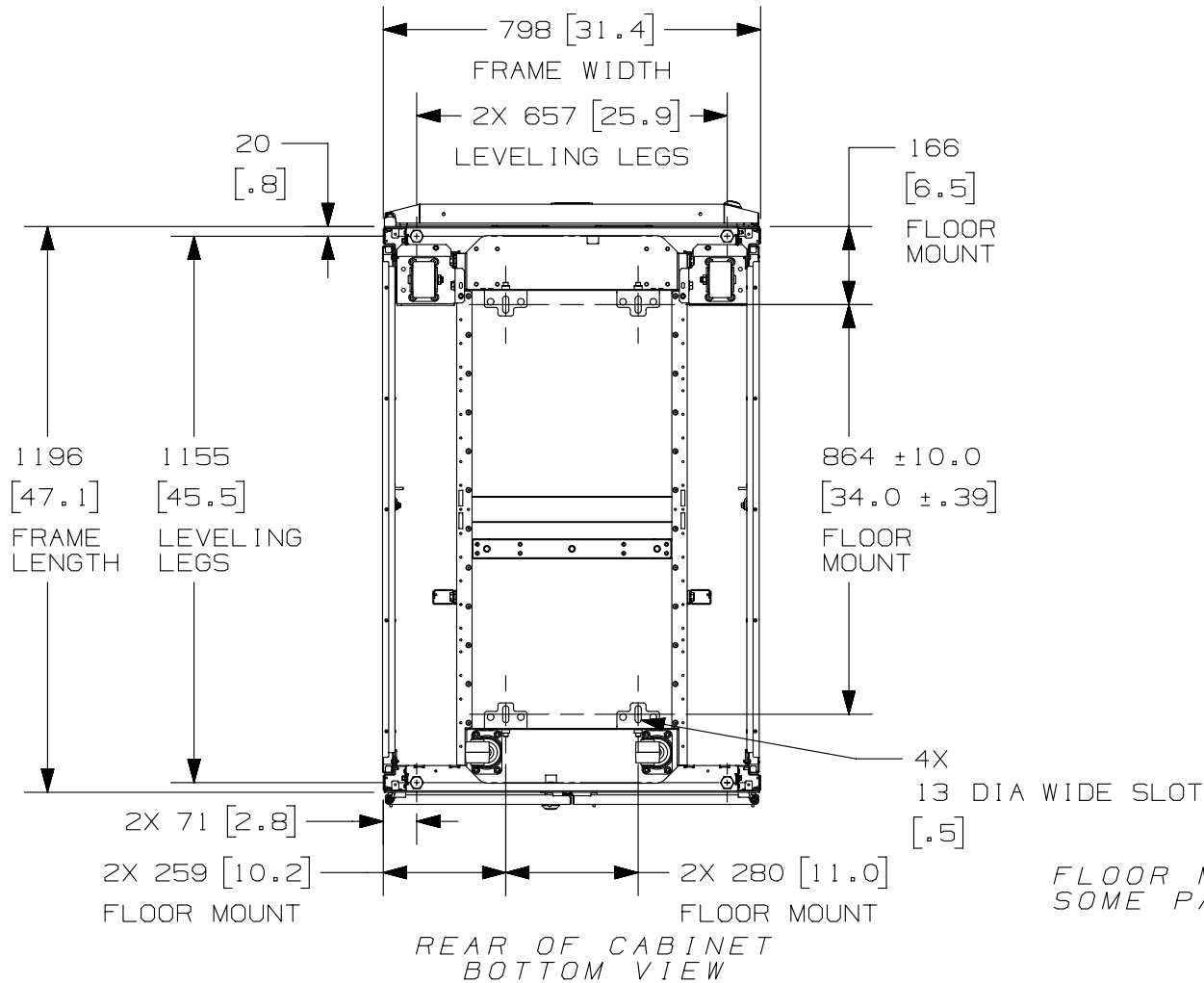

FLOOR MOUNTING HOLE LOCATIONS - SOME PARTS REMOVED FOR CLARITY

REAR OF CABINET
BOTTOM VIEW

| REV | DATE | BY | CHK | APR | DESCRIPTION | ECN |
|-----|----------|------|-----|------|--------------------------------|-------------|
| 02A | 11-14-14 | PBS | ADP | TCN | SEE SHEET 1 OF 5 FOR REVISIONS | V09000BX |
| 00B | 5-21-13 | MDCA | JDW | JDWE | SEE SHEET 1 OF 5 FOR REVISIONS | 12V305TM-DC |
| 00A | 8-29-12 | TWV | JDW | PBD | SEE SHEET 1 OF 5 FOR REVISIONS | 12V305TM-DC |

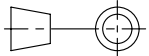
| | | | | | | |
|--------------------------------------------------------------------------------------------------------------|-----------------|------------|---------------|------------|----------------|--------------------------------|
| TITLE NET-ACCESS S-TYPE CABINET 800mm WIDE X 1200mm DEEP FAMILY CONTROL DRAWING | | | | | | |
| ITEM REVISION NAME 12V305TM/02 | | | | | PANDUIT | |
| DATASET FILE NAME 12V305TM_DC/02A | | | | | | |
| MATERIAL: N/A | | | | | | DRAWING NUMBER: 12V305TM-DC |
|  THIRD ANGLE PROJECTION | | | | | | |
| DRAWN BY TWV | DATE 8-29-12 | CHK JDW | SCALE NONE | SHT 5 OF 5 | | SIZE A |

D10100DA/16

X-ON Electronics

Largest Supplier of Electrical and Electronic Components

Click to view similar products for [Racks & Rack Cabinets](#) category:

Click to view products by [Panduit](#) manufacturer:

Other Similar products are found below :

[1440-0133-36](#) [5231308-07](#) [UNC-3-7-5-PLAIN](#) [UNC-23/4-6-6-PLAIN](#) [UPR 525-17-14 BLU/WHT](#) [RM2U19BKFP](#) [RM3U19BKFP](#)
[RM2U1918SBK](#) [RM4U1922SBK](#) [RM4U1918SBK](#) [RM1U1922SBK](#) [HDR6UBK](#) [RM4U1908VBK](#) [RM1UMTGFL](#) [DN-W19 06U/450](#) [DN-](#)
[W19 12U/450](#) [G17083UBK](#) [P32180011](#) [P32180012](#) [P32180021](#) [P32180022](#) [P32180031](#) [P32180132](#) [G17081UG](#) [G17082UG](#) [G17083UG](#)
[C2F193523BK1](#) [C2F193531BK1](#) [C2F197031LG1](#) [C2RR194231LG1](#) [C4RR247731DBK1](#) [DNRR1963LDK](#) [DNRR1970LDK](#)
[DNRR1977DCK](#) [HWMR1920UBK](#) [HWMR1932UBK](#) [RB-2P77](#) [RB-AV18](#) [RB-AV27](#) [RB-FW6](#) [RB-WR2](#) [RCHV1901717LG1](#)
[RM1U0804SBK](#) [RM1U0804VBK](#) [RM1U0808SBK](#) [RM1U0808VBK](#) [RM1U1908SBK](#) [RM1U1908VBK](#) [RM1U1913SBK](#) [RM1U1913VBK](#)