

## SURFACE MOUNT SCHOTTKY DIODE ARRAYS

These devices feature electrically-isolated Schottky diodes connected in various configurations housed in a very small SOT-363 (SC70-6L)

### FEATURES

- Maximum forward voltage @ 10mA of 0.5V
- Maximum leakage current @ 25V of 1.0uA
- Reverse voltage rating of 40V
- Lead free in compliance with EU RoHS 2011/65/EU directive
- ; fYyb'a c`X]b[ `Wta dci bX'Ug'dYf`-97 \*%&(-`GfX''fk Uc[ Yb': fYYL

### APPLICATIONS

- Rail-to-rail ESD protection
- Overshoot and undershoot switching control
- Mobile phones and accessories
- Video game consoles connector ports

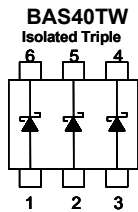
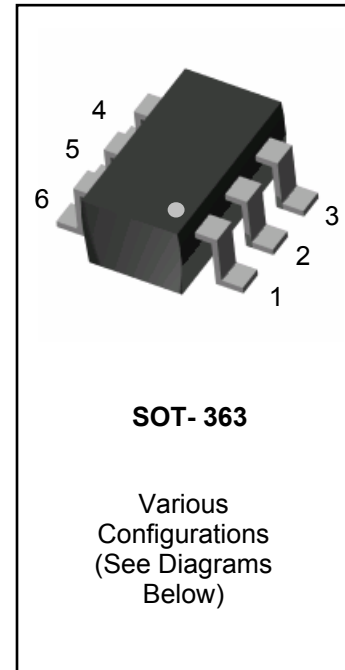

Marking Code: S40

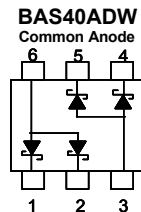

Marking Code: S42

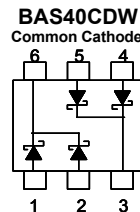

Marking Code: S43

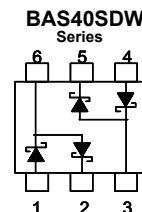

Marking Code: S44

### MAXIMUM RATINGS (Per Diode) $T_J = 25^\circ\text{C}$ Unless otherwise noted

Rating	Symbol	Value	Units
Repetitive Peak Reverse Voltage	$V_{RRM}$	40	V
Continuous Reverse Voltage	$V_R$	40	V
Continuous Forward Current	$I_F$	200	mA
Non-repetitive Peak Forward Current, t = 1sec, Square Wave	$I_{FSM}$	600	mA
Total Power Dissipation (Note 1)	$P_{tot}$	225	mW
Operating Junction Temperature Range	$T_J$	-55 to 125	$^\circ\text{C}$
Storage Temperature Range	$T_{stg}$	-65 to 125	$^\circ\text{C}$

Note 1. FR-5 Board 1.0 x 0.75 x 0.062 in.

### THERMAL CHARACTERISTICS

Characteristic	Symbol	Value	Units
Thermal Resistance, Junction to Ambient	$R_{\theta JA}$	556	$^\circ\text{C/W}$

**ELECTRICAL CHARACTERISTICS (Per Diode)**  $T_j = 25^\circ\text{C}$  Unless otherwise noted

Parameter	Symbol	Conditions	Min	Typ	Max	Units
Breakdown Voltage (Note 1)	$V_{BR}$	$I_{BR} = 10\mu\text{A}$	40	-	-	V
Forward Voltage (Note 1)	$V_F$	$I_F = 1.0\text{mA}$	-	-	380	mV
		$I_F = 10\text{mA}$	-	-	500	
		$I_F = 40\text{mA}$	-	-	1000	
Reverse Leakage Current (Note 1)	$I_R$	$V_R = 25\text{V}$	-	-	1.0	$\mu\text{A}$
Total Capacitance	$C_T$	0Vdc Bias, $f = 1\text{ MHz}$	-	-	5.0	pF
Reverse Recovery Time (See Figure 1)	$t_{rr}$	$I_F = 10\text{mA}$ , $I_R = 10\text{mA}$ $R_L = 100\text{ Ohms}$ ; measured at $I_{R\text{rec}} = 1\text{mA}$	-	-	5.0	ns

Note 1. Short duration pulse to minimize self-heating effect

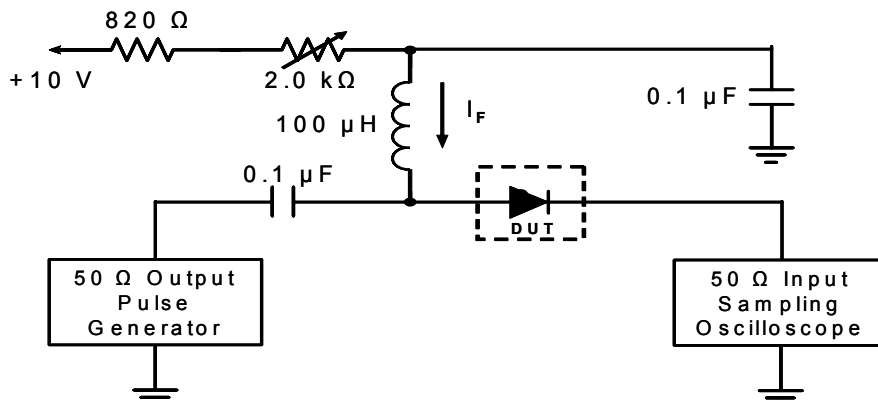

- Notes: 1. A 2.0k $\Omega$  variable resistor adjusted for a forward current ( $I_F$ ) to 10mA  
2. Input pulse is adjusted to  $I_{R(\text{peak})}$  is equal to 10mA

**Figure 1. REVERSE RECOVERY TIME EQUIVALENT TEST CIRCUIT**

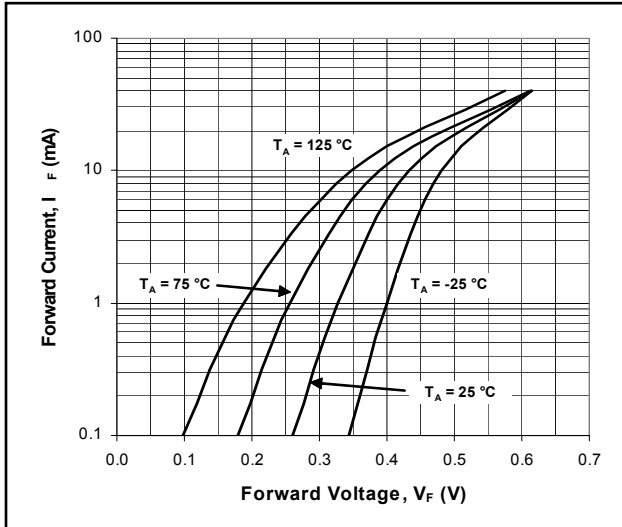

Fig. 2. Typical Forward Characteristics

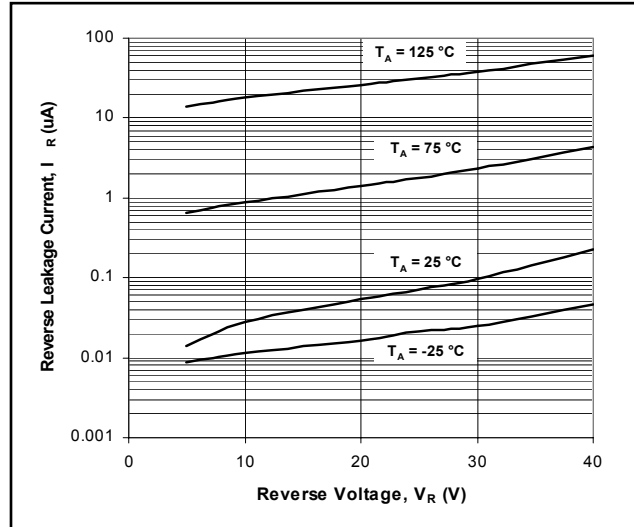

Fig. 3. Typical Reverse Characteristics

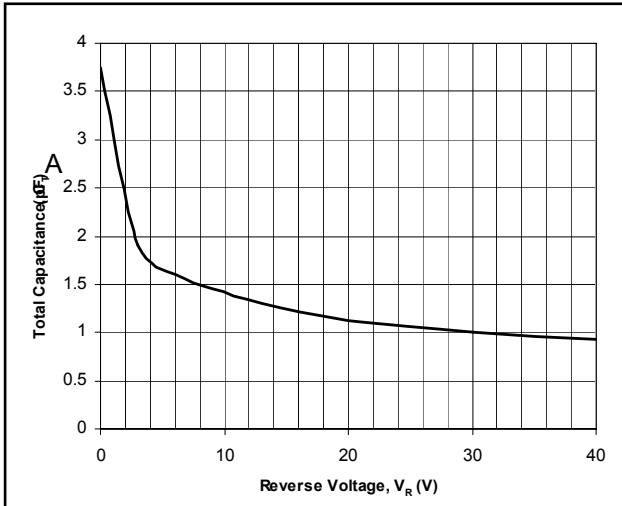

Fig. 4. Typical Capacitance

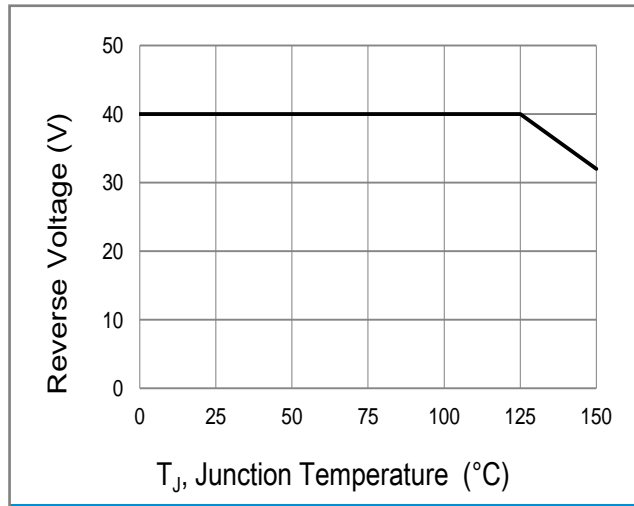

Fig.5 Operating Temperature Derating Curve



## PACKAGE LAYOUT AND SUGGESTED PAD DIMENSIONS

### SOT-363

Unit : inch(mm)

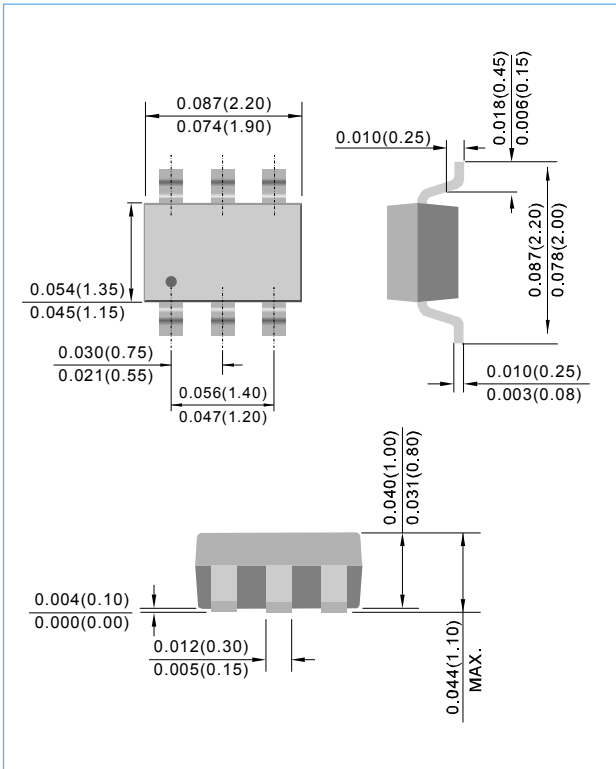

### SOT-363

Unit : inch(mm)

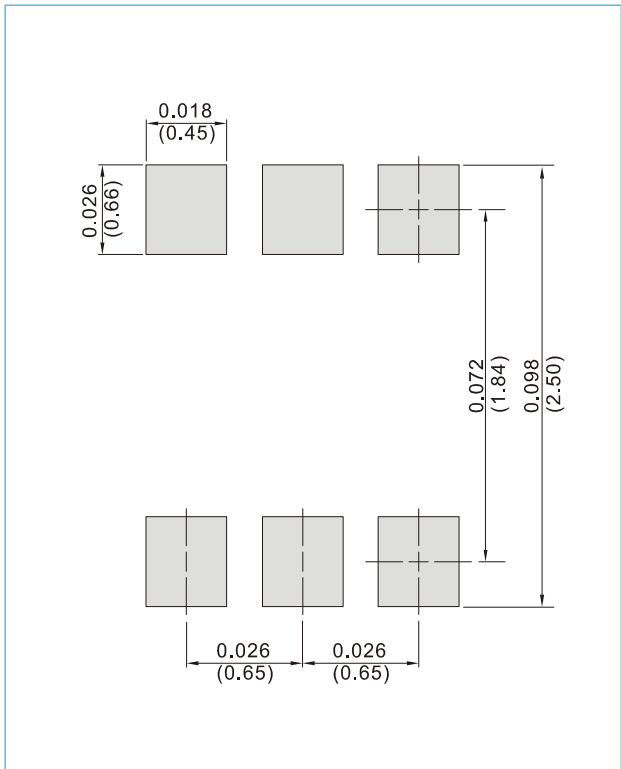

## ORDERING INFORMATION

BAS40xxx T/R7 - 7" reel, 3K units per reel

BAS40xxx T/R13 - 13" reel, 10K units per reel

# BAS40TW/ADW/CDW/SDW

## Part No\_packing code\_Version

BAS40TW\_R1\_00001

BAS40TW\_R2\_00001

For example :

**RB500V-40\_R2\_00001**

Part No.

Serial number

Version code means HF

Packing size code means 13"

Packing type means T/R

Packing Code <b>XX</b>				Version Code <b>XXXXX</b>		
Packing type	1 <sup>st</sup> Code	Packing size code	2 <sup>nd</sup> Code	HF or RoHS	1 <sup>st</sup> Code	2 <sup>nd</sup> ~5 <sup>th</sup> Code
Tape and Ammunition Box (T/B)	<b>A</b>	N/A	<b>0</b>	<b>HF</b>	<b>0</b>	serial number
Tape and Reel (T/R)	<b>R</b>	7"	<b>1</b>	<b>RoHS</b>	<b>1</b>	serial number
Bulk Packing (B/P)	<b>B</b>	13"	<b>2</b>			
Tube Packing (T/P)	<b>T</b>	26mm	<b>X</b>			
Tape and Reel (Right Oriented) (TRR)	<b>S</b>	52mm	<b>Y</b>			
Tape and Reel (Left Oriented) (TRL)	<b>L</b>	PANASERT T/B CATHODE UP (PBCU)	<b>U</b>			
FORMING	<b>F</b>	PANASERT T/B CATHODE DOWN (PBCD)	<b>D</b>			

# **BAS40TW/ADW/CDW/SDW**

---

## **Disclaimer**

- Reproducing and modifying information of the document is prohibited without permission from Panjit International Inc..
- Panjit International Inc. reserves the rights to make changes of the content herein the document anytime without notification. Please refer to our website for the latest document.
- Panjit International Inc. disclaims any and all liability arising out of the application or use of any product including damages incidentally and consequentially occurred.
- Panjit International Inc. does not assume any and all implied warranties, including warranties of fitness for particular purpose, non-infringement and merchantability.
- Applications shown on the herein document are examples of standard use and operation. Customers are responsible in comprehending the suitable use in particular applications. Panjit International Inc. makes no representation or warranty that such applications will be suitable for the specified use without further testing or modification.
- The products shown herein are not designed and authorized for equipments requiring high level of reliability or relating to human life and for any applications concerning life-saving or life-sustaining, such as medical instruments, transportation equipment, aerospace machinery et cetera. Customers using or selling these products for use in such applications do so at their own risk and agree to fully indemnify Panjit International Inc. for any damages resulting from such improper use or sale.
- Since Panjit uses lot number as the tracking base, please provide the lot number for tracking when complaining.

## X-ON Electronics

Largest Supplier of Electrical and Electronic Components

*Click to view similar products for [Schottky Diodes & Rectifiers](#) category:*

*Click to view products by [Panjit](#) manufacturer:*

Other Similar products are found below :

[MA4E2039](#) [D1FH3-5063](#) [MBR0530L-TP](#) [MBR10100CT-BP](#) [MBR1545CT](#) [MMBD301M3T5G](#) [RB160M-50TR](#) [RB551V-30](#)  
[BAS16E6433HTMA1](#) [BAT 54-02LRH E6327](#) [NSR05F40QNXT5G](#) [JANS1N6640](#) [SB07-03C-TB-H](#) [SB1003M3-TL-W](#) [SK310-T](#) [SK32A-](#)  
[LTP](#) [SK34B-TP](#) [SS3003CH-TL-E](#) [GA01SHT18](#) [CRS10I30A\(TE85L,QM](#) [MA4E2501L-1290](#) [MBRB30H30CT-1G](#) [SB007-03C-TB-E](#)  
[SK32A-TP](#) [SK33B-TP](#) [SK38B-TP](#) [NRVBM120LT1G](#) [NTE505](#) [NTSB30U100CT-1G](#) [SS15E-TP](#) [ACDBA1100LR-HF](#) [ACDBA1200-HF](#)  
[ACDBA140-HF](#) [ACDBA2100-HF](#) [ACDBA3100-HF](#) [CDBQC0530L-HF](#) [CDBQC0240LR-HF](#) [ACDBA260LR-HF](#) [ACDBA1100-HF](#)  
[SK310B-TP](#) [MA4E2502L-1246](#) [MA4E2502H-1246](#) [NRVBM120ET1G](#) [NSR01L30MXT5G](#) [SB560](#) [PMAD1108-LF](#) [SD103ATW-TP](#)  
[1N5819T-G](#) [PDS1040Q-13](#) [MBR3060FCTe3/TU](#)