



BC817DPN

DUAL NPN/PNP GENERAL PURPOSE TRANSISTORS

Voltage 45/-45V **Current** 0.5/-0.5A

Features

- General purpose amplifier applications
- High collector current capability
- Excellent DC current gain characteristics
- Lead free in compliance with EU RoHS2.0 (2011/65/EU & 2015/865/EU directive).
- Green molding compound as per IEC61249 Std.. (Halogen Free)

Mechanical Data

- Case : SOT-23 6L Package
- Terminals : Solderable per MIL-STD-750, Method 2026
- Approx. Weight : 0.0005 ounces, 0.014 grams
- Marking : 8PN

SOT-23 6L

Unit: inch(mm)

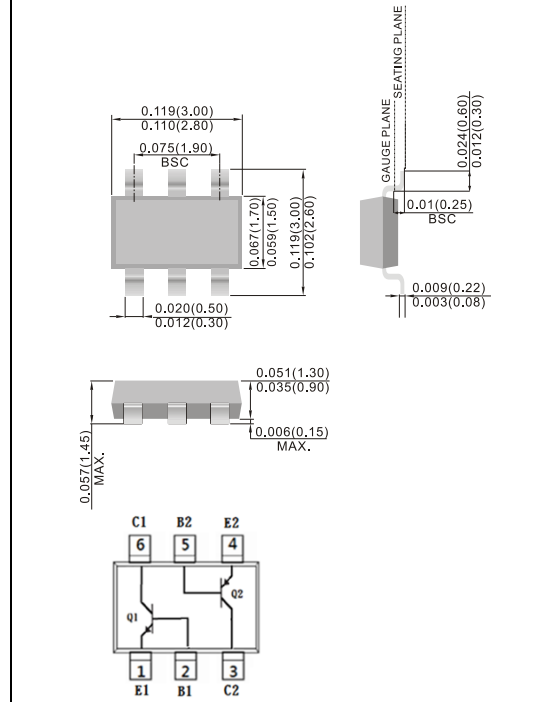

Maximum Ratings and Thermal Characteristics (T_A=25°C unless otherwise noted)

PARAMETER	SYMBOL	LIMIT		UNITS
		NPN	PNP	
Collector-Base Voltage	V _{CB0}	50	-50	V
Collector-Emitter Voltage	V _{CEO}	45	-45	V
Emitter-Base Voltage	V _{EBO}	5	-5	V
Collector Current (DC)	I _C	0.5	-0.5	A
Collector Current (Pulse)	I _{CP}	1	-1	A
Base Current	I _B	0.1	-0.1	A
Collector Power Dissipation	P _D	330		mW
Operating Junction and Storage Temperature Range	T _J , T _{STG}	-55~150		°C
Thermal Resistance from Junction to Ambient ^(Note)	R _{θJA}	378		°C/W

Note: Mounted on FR4 PCB at 1 inch square copper pad.



BC817DPN

Electrical Characteristics Q1 ($T_A=25^{\circ}\text{C}$ unless otherwise noted)

PARAMETER	SYMBOL	TEST CONDITION	MIN.	TYP.	MAX.	UNITS
OFF Characteristics						
Collector-Emitter Breakdown Voltage	BV_{CEO}	$I_C=10\text{mA}, I_B=0\text{A}$	45	-	-	V
Collector-Base Breakdown Voltage	BV_{CBO}	$I_C=0.01\text{mA}, I_E=0\text{A}$	50	-	-	V
Emitter-Base Breakdown Voltage	BV_{EBO}	$I_E=0.01\text{mA}, I_C=0\text{A}$	5	-	-	V
Collector Cutoff Current	I_{CBO}	$V_{CB}=20\text{V}, I_E=0\text{A}$	-	-	100	nA
Emitter Cutoff Current	I_{EBO}	$V_{EB}=5\text{V}, I_C=0\text{A}$	-	-	100	nA
ON characteristics						
DC Current Gain (Note1)	h_{FE}	$V_{CE}=1\text{V}, I_C=0.1\text{A}$	100	-	600	-
		$V_{CE}=1\text{V}, I_C=0.5\text{A}$	40	-	-	
Collector-Emitter Saturation Voltage (Note1)	$V_{CE(SAT)}$	$I_C=0.5\text{A}, I_B=50\text{mA}$	-	-	0.7	V
Base-Emitter Turn-on Voltage (Note1)	$V_{BE(ON)}$	$V_{CE}=1\text{V}, I_C=0.5\text{A}$	-	-	1.2	V
Transition Frequency	f_T	$V_{CE}=5\text{V}, I_C=0.01\text{A}$ $F=100\text{MHz}$	100	-	-	MHz
Collector Output Capacitance	C_{OB}	$V_{CB}=10\text{V}, I_E=0\text{A},$ $F=1\text{MHz}$	-	7	-	pF

Note: 1. Pulse width $\leq 300\mu\text{s}$, Duty cycle $\leq 2\%$



BC817DPN

Electrical Characteristics Q2 (T_A=25° C unless otherwise noted)

PARAMETER	SYMBOL	TEST CONDITION	MIN.	TYP.	MAX.	UNITS
OFF Characteristics						
Collector-Emitter Breakdown Voltage	BV _{CEO}	I _C = -10mA, I _B = 0A	-45	-	-	V
Collector-Base Breakdown Voltage	BV _{CBO}	I _C = -0.01mA, I _E = 0A	-50	-	-	V
Emitter-Base Breakdown Voltage	BV _{EBO}	I _E = -0.01mA, I _C = 0A	-5	-	-	V
Collector Cutoff Current	I _{CBO}	V _{CB} = -20V, I _E = 0A	-	-	-100	nA
Emitter Cutoff Current	I _{EBO}	V _{EB} = -4V, I _C = 0A	-	-	-100	nA
ON characteristics						
DC Current Gain (Note1)	h _{FE}	V _{CE} = -1V, I _C = -0.1A	100	-	600	-
		V _{CE} = -1V, I _C = -0.5A	40	-	-	
Collector-Emitter Saturation Voltage (Note1)	V _{CE(SAT)}	I _C = -0.5A, I _B = -50mA	-	-	-0.7	V
Base-Emitter Turn-on Voltage (Note1)	V _{BE(ON)}	V _{CE} = -1V, I _C = -0.5A	-	-	-1.2	V
Transition Frequency	f _T	V _{CE} = -5V, I _C = -0.01A F=100MHz	100	-	-	MHz
Collector Output Capacitance	C _{OB}	V _{CB} = -10V, I _E = 0A, F=1MHz	-	7	-	pF

Note: 1. Pulse width ≤ 300us, Duty cycle ≤ 2%



BC817DPN

NPN TYPICAL CHARACTERISTIC CURVES

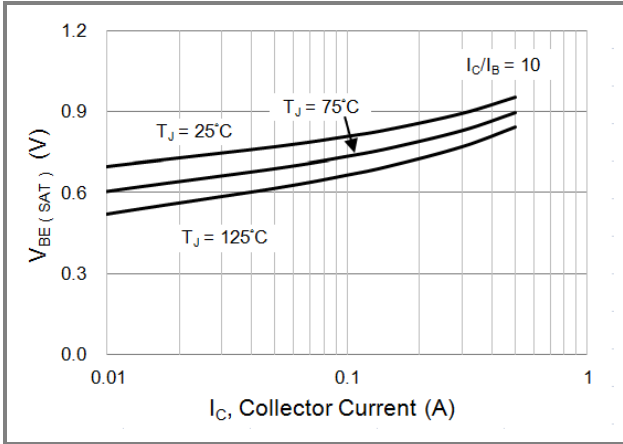

Fig.1 Typical Base-Emitter Saturation Voltage

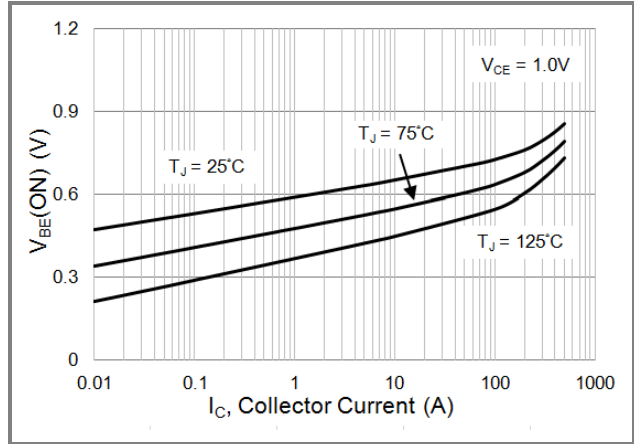

Fig.2 Typical Base-Emitter Turn ON Voltage

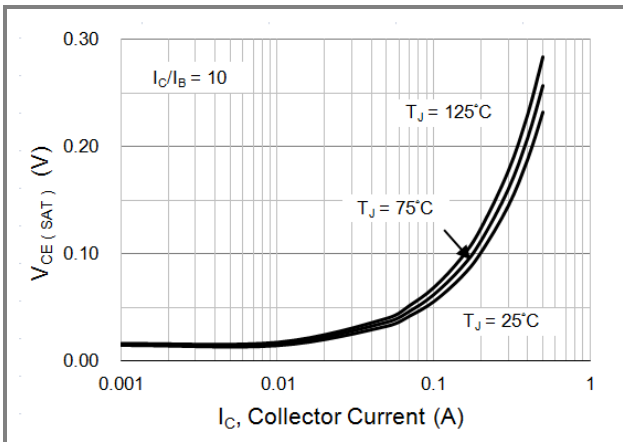

Fig.3 Typical Collector-Emitter Saturation

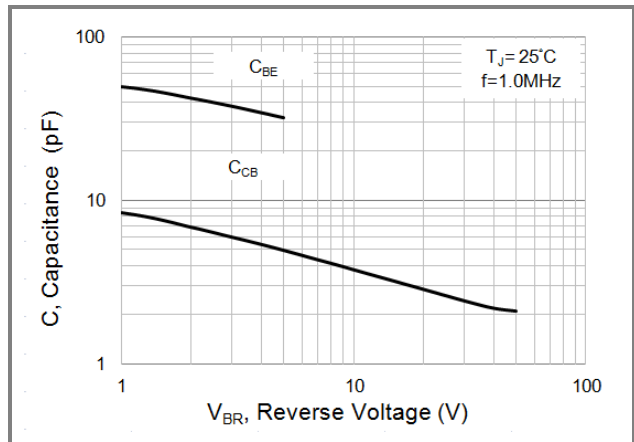

Fig.4 Typical Capacitance

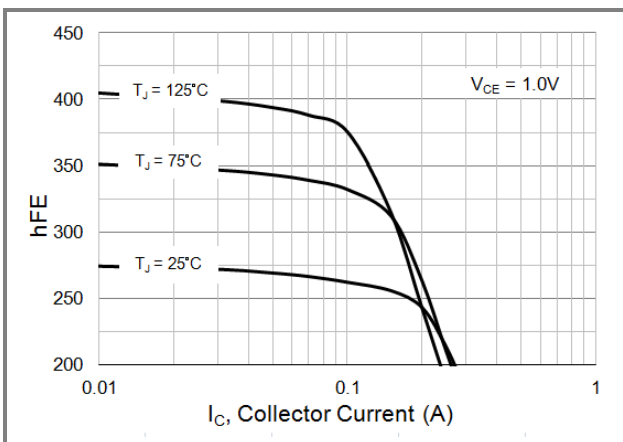

Fig.5 Typical DC Current Gain



BC817DPN

PNP TYPICAL CHARACTERISTIC CURVES

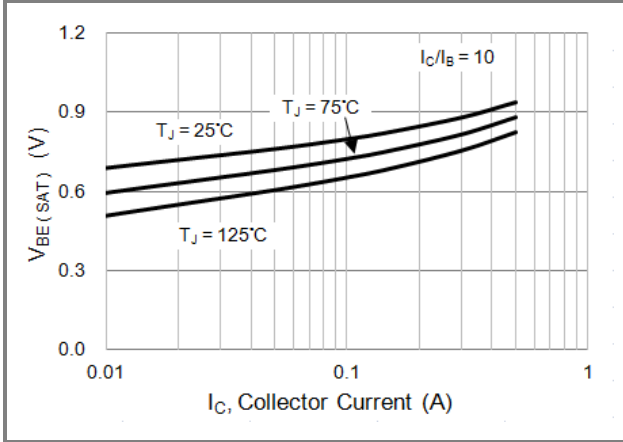

Fig.1 Typical Base-Emitter Saturation Voltage

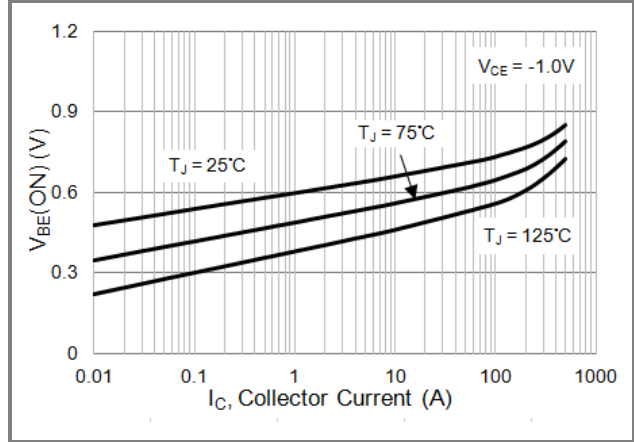

Fig.2 Typical Base-Emitter Turn ON Voltage

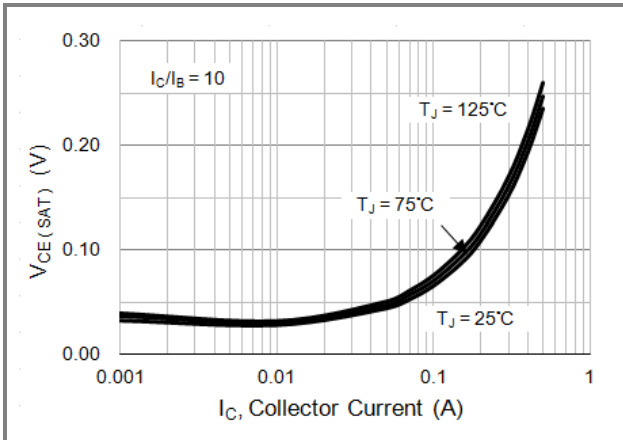

Fig.3 Typical Collector-Emitter Saturation

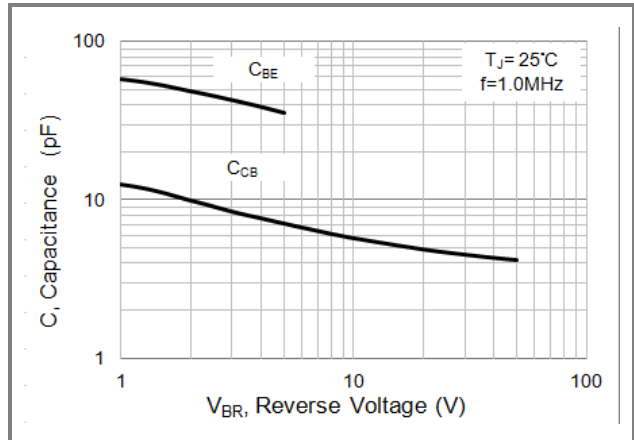

Fig.4 Typical Capacitance

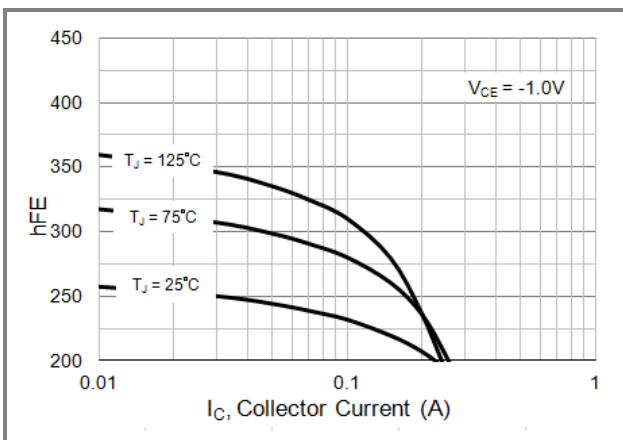

Fig.5 Typical DC Current Gain



BC817DPN

PART NO PACKING CODE VERSION

Part No Packing Code	Package Type	Packing Type	Marking	Version
BC817DPN_R1_00001	SOT-23 6L	3K pcs / 7" reel	8PN	Halogen free
BC817DPN_R2_00001	SOT-23 6L	10K pcs / 13" reel	8PN	Halogen free

MOUNTING PAD LAYOUT

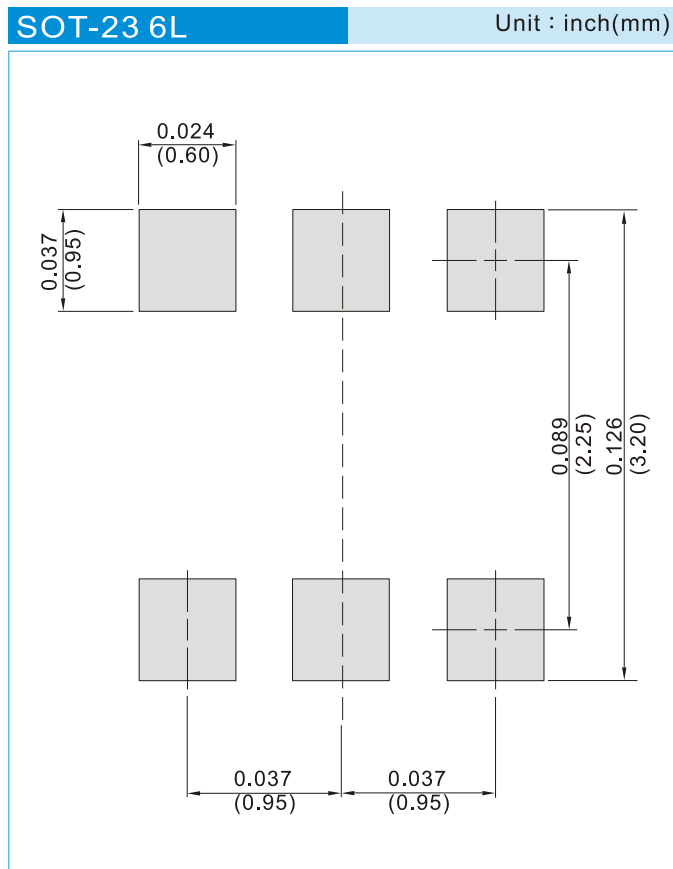



BC817DPN

Disclaimer

- Reproducing and modifying information of the document is prohibited without permission from Panjit International Inc..
- Panjit International Inc. reserves the rights to make changes of the content herein the document anytime without notification. Please refer to our website for the latest document.
- Panjit International Inc. disclaims any and all liability arising out of the application or use of any product including damages incidentally and consequentially occurred.
- Panjit International Inc. does not assume any and all implied warranties, including warranties of fitness for particular purpose, non-infringement and merchantability.
- Applications shown on the herein document are examples of standard use and operation. Customers are responsible in comprehending the suitable use in particular applications. Panjit International Inc. makes no representation or warranty that such applications will be suitable for the specified use without further testing or modification.
- The products shown herein are not designed and authorized for equipments requiring high level of reliability or relating to human life and for any applications concerning life-saving or life-sustaining, such as medical instruments, transportation equipment, aerospace machinery et cetera. Customers using or selling these products for use in such applications do so at their own risk and agree to fully indemnify Panjit International Inc. for any damages resulting from such improper use or sale.
- Since Panjit uses lot number as the tracking base, please provide the lot number for tracking when complaining.

X-ON Electronics

Largest Supplier of Electrical and Electronic Components

Click to view similar products for [Bipolar Transistors - BJT category](#):

Click to view products by [Panjit manufacturer](#):

Other Similar products are found below :

[619691C](#) [MCH4017-TL-H](#) [BC546/116](#) [BC556/FSC](#) [BC557/116](#) [BSW67A](#) [HN7G01FU-A\(T5L,F,T](#) [NJVMJD148T4G](#)
[NSVMMBT6520LT1G](#) [NTE187A](#) [NTE195A](#) [NTE2302](#) [NTE2330](#) [NTE2353](#) [NTE316](#) [NTE63](#) [NTE65](#) [C4460](#) [SBC846BLT3G](#) [2SA1419T-](#)
[TD-H](#) [2SA1721-O\(TE85L,F\)](#) [2SA1727TLP](#) [2SA2126-E](#) [2SB1202T-TL-E](#) [2SB1204S-TL-E](#) [2SC4731T-AY](#) [2SC5488A-TL-H](#)
[2SD2150T100R](#) [SP000011176](#) [FJPF5304DTU](#) [FMC5AT148](#) [FMMTA92QTA](#) [2N2369ADCSM](#) [2SB1202S-TL-E](#) [2SB1324-TD-E](#)
[2SC2412KT146S](#) [2SC3332T](#) [2SC3902S](#) [2SC4618TLN](#) [2SC5231C8-TL-E](#) [2SC5490A-TL-H](#) [2SD1685F](#) [2SD1816S-TL-E](#) [2SD1816T-TL-E](#)
[CMXT2207 TR](#) [CPH6501-TL-E](#) [MCH4021-TL-E](#) [TTC012\(Q\)](#) [BULD128DT4](#) [US6T6TR](#)