



BZX84C2V4W-AU SERIES

SURFACE MOUNT SILICON ZENER DIODES

VOLTAGE 2.4 to 75 Volts **POWER** 200 mWatts

SOT-323 Unit : inch(mm)

FEATURES

- Planar Die construction
- 200mW Power Dissipation
- Ideally Suited for Automated Assembly Processes
- Acquire quality system certificate : TS16949
- AEC-Q101 qualified
- Lead free in comply with EU RoHS 2002/95/EC directives.
- Green molding compound as per IEC61249 Std. . (Halogen Free)

MECHANICAL DATA

- Case: SOT-323, Molded Plastic
- Terminals: Solderable per MIL-STD-750, Method 2026
- Polarity: See Diagram Below
- Approx. Weight: 0.0048 grams
- Mounting Position: Any

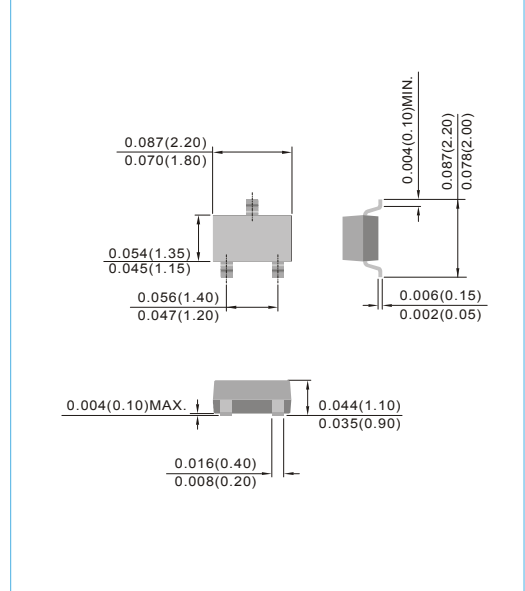

MAXIMUM RATINGS AND ELECTRICAL CHARACTERISTICS

PARAMETER	SYMBOL	VALUE	UNITS
Power Dissipation @ $T_A=25^{\circ}\text{C}$ (Note A)	P_D	200	mW
Operating Junction and Storage Temperature Range	T_J	-55 to +150	$^{\circ}\text{C}$

SINGLE

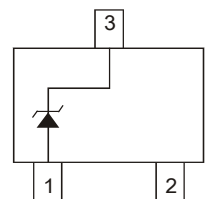

NOTES:

A. Mounted on 5.0mm²(.013mm thick) land areas.



BZX84C2V4W-AU SERIES

Part Number	Nominal Zener Voltage			Max. Zener Impedance				Max Reverse Leakage Current		Marking Code
	V _Z @ I _{ZT}			Z _{ZT} @ I _{ZT}		Z _{ZK} @ I _{ZK}		I _R @ V _R		
	Nom. V	Min. V	Max. V	Ω	mA	Ω	mA	μA	V	
200 mWatts Zener Diodes										
BZX84C2V4W-AU	2.4	2.28	2.52	100	5.0	600	1.00	50	1.0	W1
BZX84C2V7W-AU	2.7	2.57	2.84	100	5.0	600	1.00	20	1.0	W2
BZX84C3W-AU	3.0	2.85	3.15	95	5.0	600	1.00	10	1.0	W3
BZX84C3V3W-AU	3.3	3.14	3.47	95	5.0	600	1.00	5.0	1.0	W4
BZX84C3V6W-AU	3.6	3.42	3.78	90	5.0	600	1.00	5.0	1.0	W5
BZX84C3V9W-AU	3.9	3.71	4.10	90	5.0	600	1.00	3.0	1.0	W6
BZX84C4V3W-AU	4.3	4.09	4.52	90	5.0	600	1.00	3.0	1.0	W7
BZX84C4V7W-AU	4.7	4.47	4.94	80	5.0	500	1.00	3.0	2.0	W8
BZX84C5V1W-AU	5.1	4.85	5.36	60	5.0	480	1.00	2.0	2.0	W9
BZX84C5V6W-AU	5.6	5.32	5.88	40	5.0	400	1.00	1.0	2.0	WA
BZX84C6V2W-AU	6.2	5.89	6.51	10	5.0	150	1.00	3.0	4.0	WB
BZX84C6V8W-AU	6.8	6.46	7.14	15	5.0	80	1.00	2.0	4.0	WC
BZX84C7V5W-AU	7.5	7.13	7.88	15	5.0	80	1.00	1.0	5.0	WD
BZX84C8V2W-AU	8.2	7.79	8.61	15	5.0	80	1.00	0.7	5.0	WE
BZX84C8V7W-AU	8.7	8.27	9.14	15	5.0	100	1.00	0.7	5.0	87C
BZX84C9V1W-AU	9.1	8.65	9.56	15	5.0	100	1.00	0.5	6.0	WF
BZX84C10W-AU	10	9.50	10.50	20	5.0	150	1.00	0.2	7.0	WG
BZX84C11W-AU	11	10.45	11.55	20	5.0	150	1.00	0.1	8.0	WH
BZX84C12W-AU	12	11.40	12.60	25	5.0	150	1.00	0.1	8.0	WI
BZX84C13W-AU	13	12.35	13.65	30	5.0	170	1.00	0.1	8.0	WK
BZX84C14W-AU	14	13.30	14.70	30	5.0	170	1.00	0.1	10.0	WJ
BZX84C15W-AU	15	14.25	15.75	30	5.0	200	1.00	0.1	10.5	WL
BZX84C16W-AU	16	15.20	16.80	40	5.0	200	1.00	0.1	11.2	WM
BZX84C17W-AU	17	16.15	17.85	40	5.0	200	1.00	0.1	12.2	17C
BZX84C18W-AU	18	17.10	18.90	45	5.0	225	1.00	0.1	12.6	WN
BZX84C20W-AU	20	19.00	21.00	55	5.0	225	1.00	0.1	14.0	WO
BZX84C22W-AU	22	20.90	23.10	55	5.0	250	1.00	0.1	15.4	WP
BZX84C24W-AU	24	22.80	25.20	70	5.0	250	1.00	0.1	16.8	WR
BZX84C27W-AU	27	25.65	28.35	80	5.0	300	1.00	0.1	18.9	WS
BZX84C28W-AU	28	26.60	29.40	80	5.0	300	1.00	0.1	20.50	28C
BZX84C30W-AU	30	28.50	31.50	80	5.0	300	1.00	0.1	21.00	WT
BZX84C33W-AU	33	31.35	34.65	80	5.0	325	1.00	0.1	23.10	WU
BZX84C36W-AU	36	34.20	37.80	90	5.0	350	1.00	0.1	25.20	WW
BZX84C39W-AU	39	37.05	40.95	130	5.0	350	1.00	0.1	27.30	WX
BZX84C43W-AU	43	40.85	45.15	150	5.0	375	1.00	0.1	30.10	WY
BZX84C47W-AU	47	44.65	49.35	170	5.0	375	1.00	0.1	32.90	WZ
BZX84C51W-AU	51	48.45	53.55	100	5.0	400	1.00	0.1	38.00	XA
BZX84C56W-AU	56	53.20	58.80	135	2.5	1000	1.00	0.1	42.00	X2
BZX84C62W-AU	62	58.90	65.10	150	2.5	1000	1.00	0.1	46.00	X3
BZX84C68W-AU	68	64.60	71.40	200	2.5	1000	1.00	0.1	51.00	X4
BZX84C75W-AU	75	71.25	78.75	250	2.5	1000	1.00	0.1	56.00	X5



BZX84C2V4W-AU SERIES

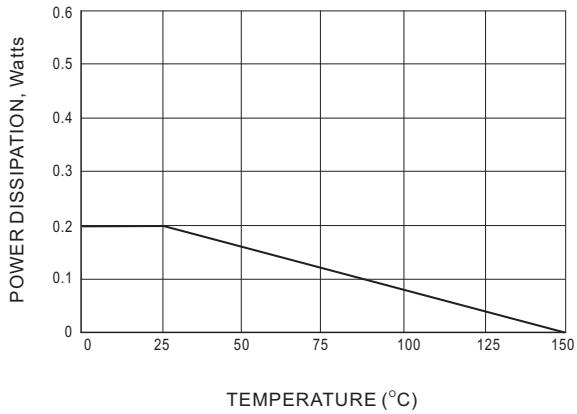

Fig.1 STEADY STATE POWER DERATING

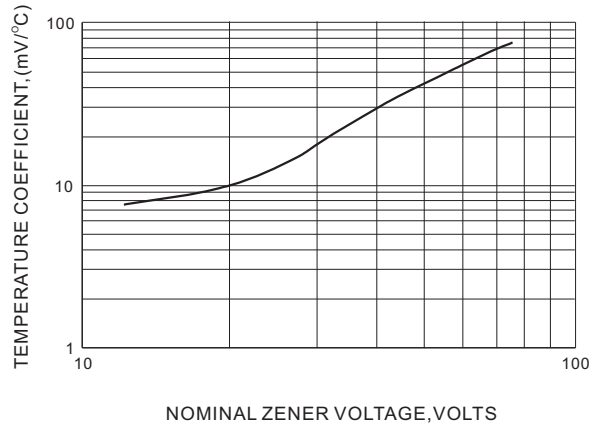

Fig.2 TEMPERATURE COEFFICIENTS

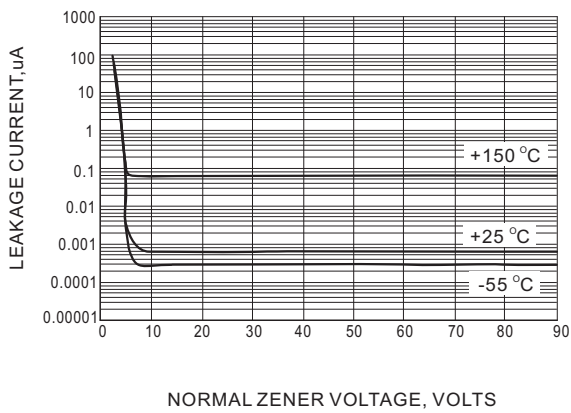

Fig.3 TYPICAL LEAKAGE CURRENT

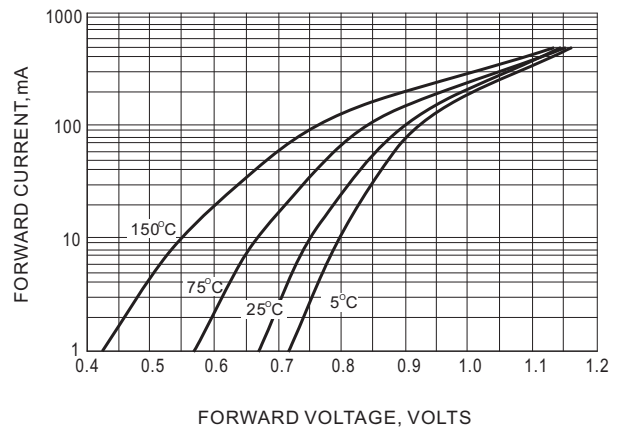
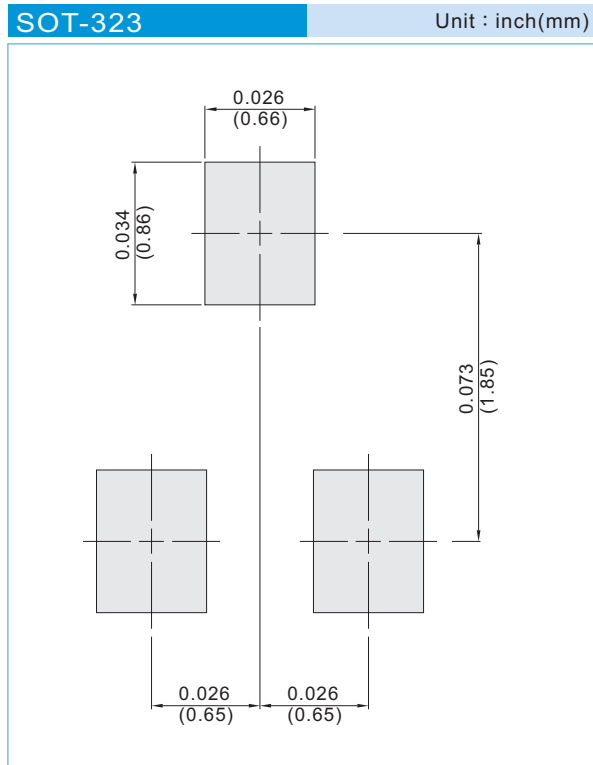

Fig.4 TYPICAL FORWARD VOLTAGE



BZX84C2V4W-AU SERIES

MOUNTING PAD LAYOUT



ORDER INFORMATION

- Packing information
T/R - 12K per 13" plastic Reel
T/R - 3K per 7" plastic Reel



BZX84C2V4W-AU SERIES

Part No_packing code_Version

BZX84C2V4W-AU_R1_000A1

BZX84C2V4W-AU_R2_000A1

For example :

RB500V-40_R2_00001

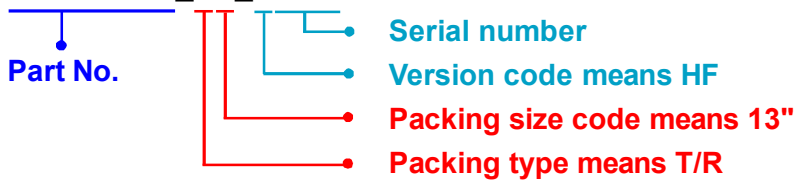

Packing Code XX				Version Code XXXXX		
Packing type	1 st Code	Packing size code	2 nd Code	HF or RoHS	1 st Code	2 nd ~5 th Code
Tape and Ammunition Box (T/B)	A	N/A	0	HF	0	serial number
Tape and Reel (T/R)	R	7"	1	RoHS	1	serial number
Bulk Packing (B/P)	B	13"	2			
Tube Packing (T/P)	T	26mm	X			
Tape and Reel (Right Oriented) (TRR)	S	52mm	Y			
Tape and Reel (Left Oriented) (TRL)	L	PANASERT T/B CATHODE UP (PBCU)	U			
FORMING	F	PANASERT T/B CATHODE DOWN (PBCD)	D			



BZX84C2V4W-AU SERIES

Disclaimer

- Reproducing and modifying information of the document is prohibited without permission from Panjit International Inc..
- Panjit International Inc. reserves the rights to make changes of the content herein the document anytime without notification. Please refer to our website for the latest document.
- Panjit International Inc. disclaims any and all liability arising out of the application or use of any product including damages incidentally and consequentially occurred.
- Panjit International Inc. does not assume any and all implied warranties, including warranties of fitness for particular purpose, non-infringement and merchantability.
- Applications shown on the herein document are examples of standard use and operation. Customers are responsible in comprehending the suitable use in particular applications. Panjit International Inc. makes no representation or warranty that such applications will be suitable for the specified use without further testing or modification.
- The products shown herein are not designed and authorized for equipments requiring high level of reliability or relating to human life and for any applications concerning life-saving or life-sustaining, such as medical instruments, transportation equipment, aerospace machinery et cetera. Customers using or selling these products for use in such applications do so at their own risk and agree to fully indemnify Panjit International Inc. for any damages resulting from such improper use or sale.

X-ON Electronics

Largest Supplier of Electrical and Electronic Components

Click to view similar products for [Zener Diodes](#) category:

Click to view products by [Panjit](#) manufacturer:

Other Similar products are found below :

[RKZ13B2KG#P1](#) [RKZ5.6B2KJ#R1](#) [DL5234B](#) [EDZTE6113B](#) [1N4682](#) [1N4691](#) [1N4693](#) [1N4732A](#) [1N4736A](#) [1N4750A](#) [1N4759ARL](#)
[1N5241B](#) [1N5365B](#) [1N5369B](#) [1N747A](#) [1N959B](#) [1N964B](#) [1N966B](#) [1N968B](#) [1N972B](#) [NTE5121A](#) [NTE5147A](#) [NTE5152A](#) [NTE5155A](#)
[NTE5164A](#) [JANS1N4974US](#) [1N4692](#) [1N4700](#) [1N4702](#) [1N4704](#) [1N4711](#) [1N4714](#) [1N4737A](#) [1N4745ARL](#) [1N4752A](#) [1N4752ARL](#)
[1N4760ARL](#) [1N5221B](#) [1N5231B-TR](#) [1N5236B](#) [1N5241BTR](#) [1N5242BTR](#) [1N5350B](#) [1N5352B](#) [1N961BRR1](#) [1N964BRL](#) [RKZ5.1BKU#P6](#)
[3SMAJ5946B-TP](#) [3SMAJ5950B-TP](#) [3SMBJ5925B-TP](#)