



ZMM5221B~ZMM5266B

SURFACE MOUNT ZENER DIODES

VOLTAGE 2.4 to 68 Volt **POWER** 500 mWatt

MINI-MELF / LL34 Unit : inch(mm)

FEATURES

- Planar Die construction
- 500mW Power Dissipation
- Ideally Suited for Automated Assembly Processes
- Lead free in compliance with EU RoHS 2.0

MECHANICAL DATA

- Case: Molded Glass MINI-MELF
- Terminals: Solderable per MIL-STD-750, Method 2026
- Approx. Weight: 0.001 ounces, 0.03 grams
- Packing information

T/R - 2.5K per 7" plastic Reel

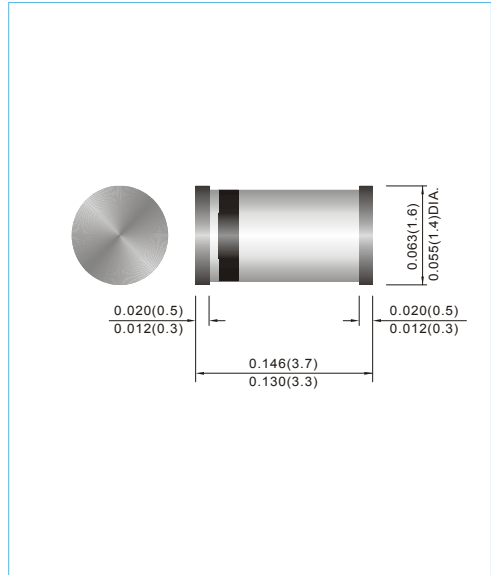
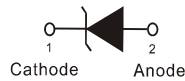

MAXIMUM RATINGS AND ELECTRICAL CHARACTERISTICS

Parameter	Symbol	Value	Units
Power Dissipation at $T_A = 25^\circ\text{C}$	P_{TOT}	500	mW
Operating Junction Temperature Range	T_J	-65 to +175	$^\circ\text{C}$
Storage Temperature Range	T_{STG}	-65 to +175	$^\circ\text{C}$

Valid provided that leads at a distance of 10mm from case are kept at ambient temperature.

Parameter	Symbol	Min.	Typ.	Max.	Units
Thermal Resistance Junction to Ambient Air	$R_{\theta JA}$	--	--	0.3	$^\circ\text{C}/\text{mW}$
Forward Voltage at $I_F = 200\text{mA}$	V_F	--	--	1.1	V

Valid provided that leads at a distance of 10mm from case are kept at ambient temperature.



ZMM5221B~ZMM5266B

Part Number	Nominal Zener Voltage			Max. Zener Impedance				Max Reverse Leakage Current		Marking code
	V _Z @ I _{ZT}			Z _{ZT} @ I _{ZT}		Z _{ZK} @ I _{ZK}		I _R @ V _R		
	Nom. V	Min. V	Max. V	Ω	mA	Ω	mA	uA	V	
ZMM5221B	2.4	2.28	2.52	30	20	1200	0.25	100	1	5221
ZMM5222B	2.5	2.38	2.63	30	20	1250	0.25	100	1	5222
ZMM5223B	2.7	2.57	2.84	30	20	1300	0.25	75	1	5223
ZMM5224B	2.8	2.66	2.94	30	20	1400	0.25	75	1	5224
ZMM5225B	3	2.85	3.15	29	20	1600	0.25	50	1	5225
ZMM5226B	3.3	3.14	3.47	28	20	1600	0.25	25	1	5226
ZMM5227B	3.6	3.42	3.78	24	20	1700	0.25	15	1	5227
ZMM5228B	3.9	3.71	4.1	23	20	1900	0.25	10	1	5228
ZMM5229B	4.3	4.09	4.52	22	20	2000	0.25	5	1	5229
ZMM5230B	4.7	4.47	4.94	19	20	1900	0.25	5	2	5230
ZMM5231B	5.1	4.85	5.36	17	20	1600	0.25	5	2	5231
ZMM5232B	5.6	5.32	5.88	11	20	1600	0.25	5	3	5232
ZMM5233B	6.0	5.7	6.3	7	20	1600	0.25	5	3.5	5233
ZMM5234B	6.2	5.89	6.51	7	20	1000	0.25	5	4	5234
ZMM5235B	6.8	6.46	7.14	5	20	750	0.25	3	5	5235
ZMM5236B	7.5	7.13	7.88	6	20	500	0.25	3	6	5236
ZMM5237B	8.2	7.79	8.61	8	20	500	0.25	3	6.5	5237
ZMM5238B	8.7	8.27	9.14	8	20	600	0.25	3	6.5	5238
ZMM5239B	9.1	8.65	9.56	10	20	600	0.25	3	7	5239
ZMM5240B	10	9.5	10.5	17	20	600	0.25	3	8	5240
ZMM5241B	11	10.45	11.55	22	20	600	0.25	2	8.4	5241
ZMM5242B	12	11.4	12.6	30	20	600	0.25	1	9.1	5242
ZMM5243B	13	12.35	13.65	13	9.5	600	0.25	0.5	9.9	5243
ZMM5244B	14	13.3	14.7	15	9	600	0.25	0.1	10	5244
ZMM5245B	15	14.25	15.75	16	8.5	600	0.25	0.1	11	5245
ZMM5246B	16	15.2	16.8	17	7.8	600	0.25	0.1	12	5246
ZMM5247B	17	16.15	17.85	19	7.4	600	0.25	0.1	13	5247
ZMM5248B	18	17.1	18.9	21	7	600	0.25	0.1	14	5248
ZMM5249B	19	18.05	19.95	23	6.6	600	0.25	0.1	14	5249
ZMM5250B	20	19	21	25	6.2	600	0.25	0.1	15	5250
ZMM5251B	22	20.9	23.1	29	5.6	600	0.25	0.1	17	5251
ZMM5252B	24	22.8	25.2	33	5.2	600	0.25	0.1	18	5252
ZMM5253B	25	23.75	26.25	35	5	600	0.25	0.1	19	5253
ZMM5254B	27	25.65	28.35	41	4.6	600	0.25	0.1	21	5254
ZMM5255B	28	26.6	29.4	44	4.5	600	0.25	0.1	21	5255
ZMM5256B	30	28.5	31.5	49	4.2	600	0.25	0.1	23	5256
ZMM5257B	33	31.35	34.65	58	3.8	700	0.25	0.1	25	5257
ZMM5258B	36	34.2	37.8	70	3.4	700	0.25	0.1	27	5258
ZMM5259B	39	37.05	40.95	80	3.2	800	0.25	0.1	30	5259
ZMM5260B	43	40.85	45.15	93	3	900	0.25	0.1	33	5260
ZMM5261B	47	44.65	49.35	150	2.7	1000	0.25	0.1	36	5261
ZMM5262B	51	48.45	53.55	125	2.5	1100	0.25	0.1	39	5262
ZMM5263B	56	53.2	58.8	150	2.2	1300	0.25	0.1	43	5263
ZMM5264B	60	57	63	170	2.1	1400	0.25	0.1	46	5264
ZMM5265B	62	58.9	65.1	185	2	1400	0.25	0.1	47	5265
ZMM5266B	68	64.6	71.4	230	1.8	1600	0.25	0.1	52	5266



ZMM5221B~ZMM5266B

RATING AND CHARACTERISTIC CURVES

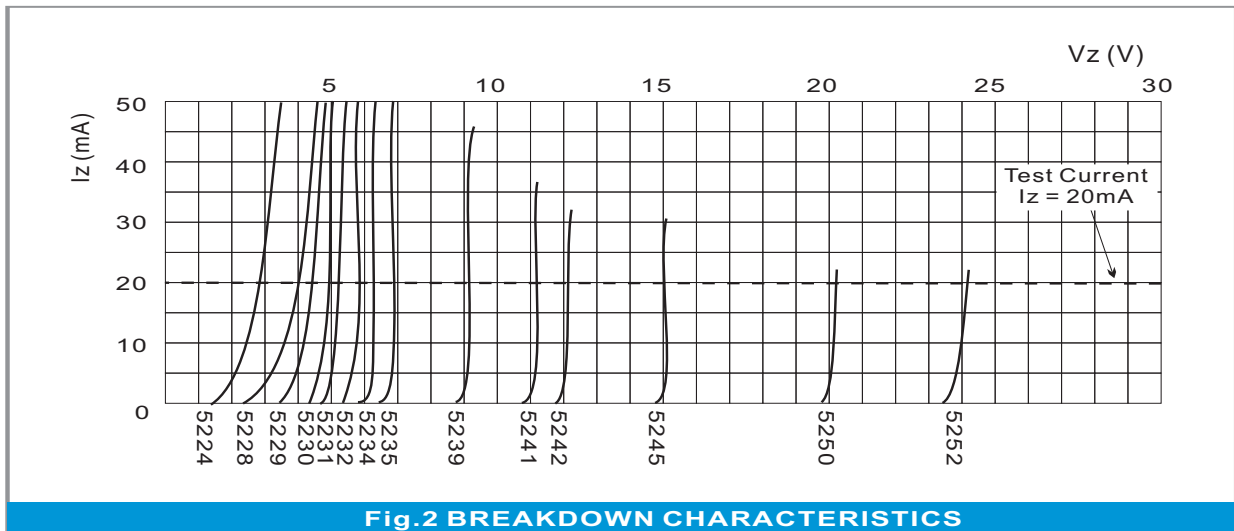
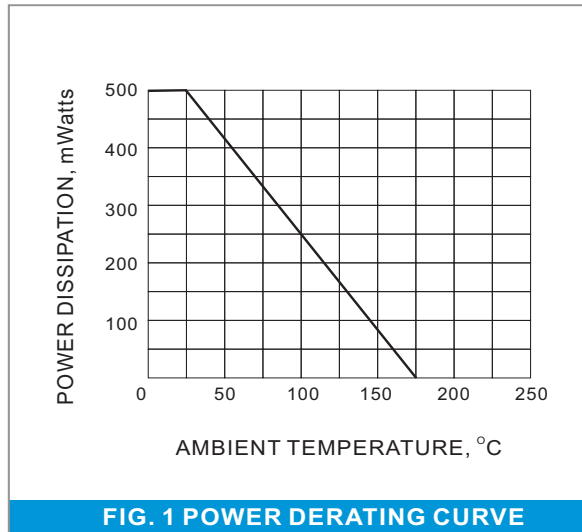



ZMM5221B~ZMM5266B

MOUNTING PAD LAYOUT

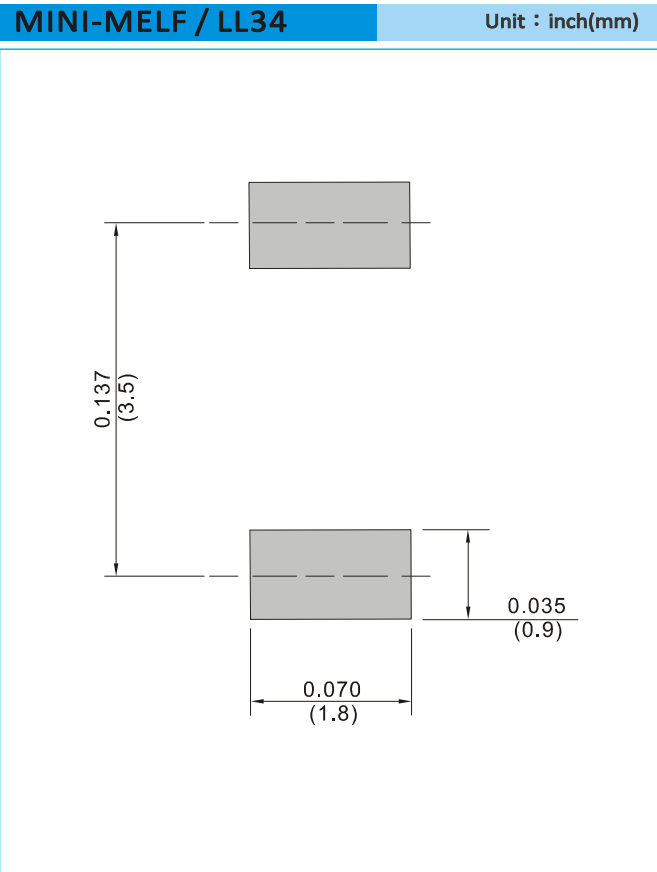

ORDER INFORMATION

- Packing information
T/R - 10K per 13" plastic Reel
T/R - 2.5K per 7" plastic Reel



ZMM5221B~ZMM5266B

Part No_packing code_Version

ZMM5221B_R1_10001

ZMM5221B_R2_10001

For example :

RB500V-40_R2_00001

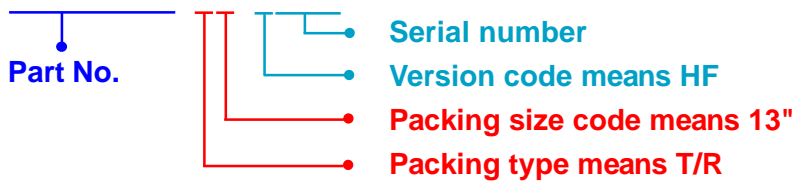

Packing Code XX				Version Code XXXXX		
Packing type	1 st Code	Packing size code	2 nd Code	HF or RoHS	1 st Code	2 nd ~5 th Code
Tape and Ammunition Box (T/B)	A	N/A	0	HF	0	serial number
Tape and Reel (T/R)	R	7"	1	RoHS	1	serial number
Bulk Packing (B/P)	B	13"	2			
Tube Packing (T/P)	T	26mm	X			
Tape and Reel (Right Oriented) (TRR)	S	52mm	Y			
Tape and Reel (Left Oriented) (TRL)	L	PANASERT T/B CATHODE UP (PBCU)	U			
FORMING	F	PANASERT T/B CATHODE DOWN (PBCD)	D			



ZMM5221B~ZMM5266B

Disclaimer

- Reproducing and modifying information of the document is prohibited without permission from Panjit International Inc..
- Panjit International Inc. reserves the rights to make changes of the content herein the document anytime without notification. Please refer to our website for the latest document.
- Panjit International Inc. disclaims any and all liability arising out of the application or use of any product including damages incidentally and consequentially occurred.
- Panjit International Inc. does not assume any and all implied warranties, including warranties of fitness for particular purpose, non-infringement and merchantability.
- Applications shown on the herein document are examples of standard use and operation. Customers are responsible in comprehending the suitable use in particular applications. Panjit International Inc. makes no representation or warranty that such applications will be suitable for the specified use without further testing or modification.
- The products shown herein are not designed and authorized for equipments requiring high level of reliability or relating to human life and for any applications concerning life-saving or life-sustaining, such as medical instruments, transportation equipment, aerospace machinery et cetera. Customers using or selling these products for use in such applications do so at their own risk and agree to fully indemnify Panjit International Inc. for any damages resulting from such improper use or sale.
- Since Panjit uses lot number as the tracking base, please provide the lot number for tracking when complaining.

X-ON Electronics

Largest Supplier of Electrical and Electronic Components

Click to view similar products for [Zener Diodes](#) category:

Click to view products by [Panjit](#) manufacturer:

Other Similar products are found below :

[RKZ13B2KG#P1](#) [DL5234B](#) [EDZTE6113B](#) [1N4682](#) [1N4693](#) [1N4732A](#) [1N4736A](#) [1N4750A](#) [1N4759ARL](#) [1N5241B](#) [1N5365B](#) [1N5369B](#)
[1N747A](#) [1N964B](#) [1N966B](#) [1N968B](#) [1N972B](#) [JANS1N4974US](#) [JANTX1N5907](#) [1N4692](#) [1N4700](#) [1N4702](#) [1N4704](#) [1N4711](#) [1N4714](#)
[1N4745ARL](#) [1N4752ARL](#) [1N4760ARL](#) [1N5221B](#) [1N5242BTR](#) [1N5350B](#) [1N5352B](#) [1N961BRR1](#) [1N964BRL](#) [RKZ5.1BKU#P6](#)
[3SMAJ5946B-TP](#) [3SMAJ5950B-TP](#) [3SMBJ5925B-TP](#) [MMSZ5230BQ-13-F](#) [MMSZ5232BQ-13-F](#) [BZX84C7V5](#) [3SMAJ5945B-TP](#)
[3SMAJ5947B-TP](#) [3SMBJ5941B-TP](#) [DL4732A-T3](#) [DZ2S240M0L](#) [SMAZ27-TP](#) [ZMM5224B-7](#) [RD16UM-T1-A](#) [RD39S-T1-A](#)