



**PARA LIGHT ELECTRONICS CO., LTD.**

4F, No.1, Lane 93, Chien Yi Road, Chung Ho City, Taipei, Taiwan, R.O.C.

Tel: 886-2-2225-3733

Fax: 886-2-2225-4800

E-mail: [para@para.com.tw](mailto:para@para.com.tw)

<http://www.para.com.tw>

**DATA SHEET**

**PART NO. : B-1408SRD**

**REV : XXXX**

CUSTOMER'S APPROVAL : \_\_\_\_\_

DCC : \_\_\_\_\_

DRAWING NO. : DS-17-05-XXXX

DATE : 2005-02-01

Page : 1

PACKAGE DIMENSIONS

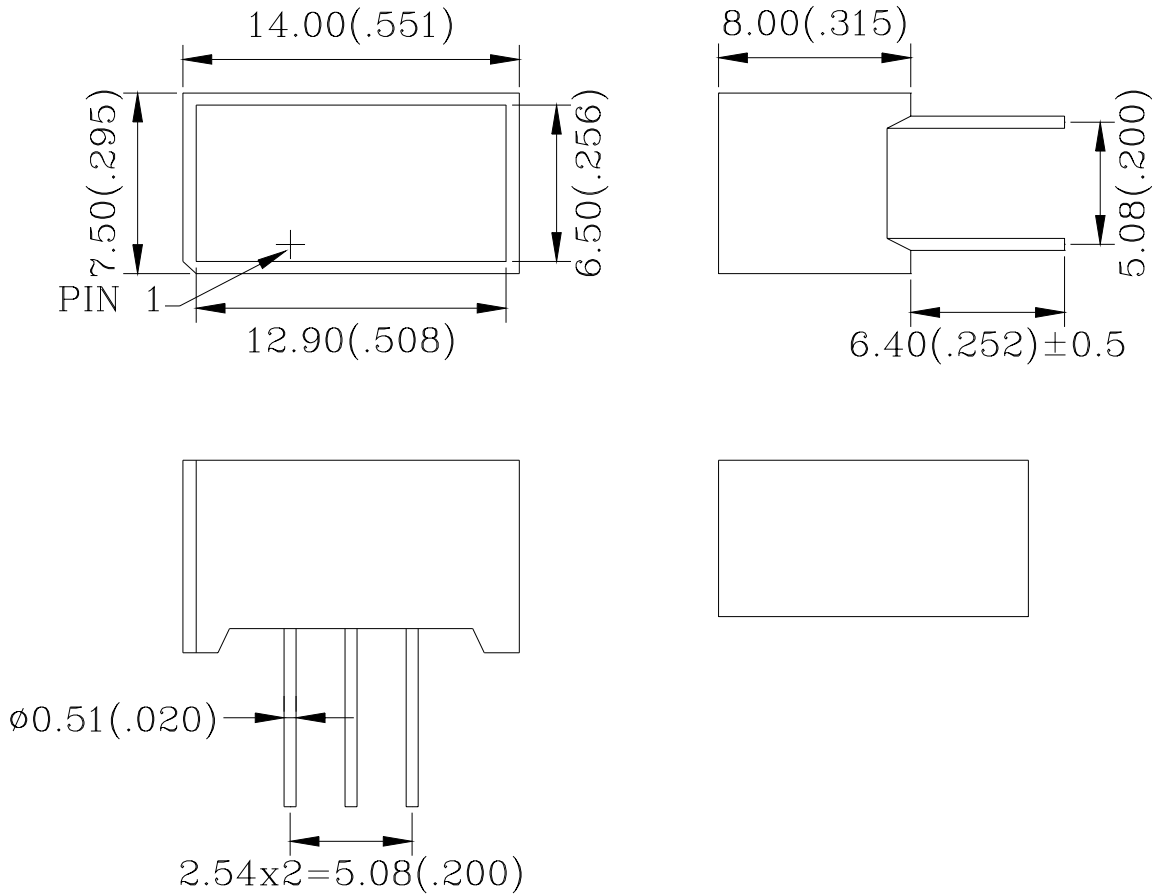

(ANODE) + 6      4 - (CATHODE)

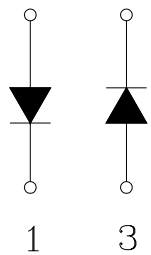

2 NO PIN  
5 NO CONNECT

- NOTES : 1. All dimensions are in millimeters. (inches)  
 2. Tolerance is  $\pm 0.25(0.010)$  unless otherwise specified.  
 3. We would like to offer you samples and mass production after you confirmed the DS and signed to return us



7.5 mmx14.0 mm SQUARE LIGHT BAR

B-1408SRD

REV:XXXX

FEATURES

- \* 7.5mmx14.0mm SQUARE LIGHT BAR
- \* EXCELLENT CHARACTER APPEARANCE
- \* I.C.COMPATIBLE
- \* LOW POWER CONSUMPTION

Raw Material :GaAIAs/GaAs

ABSOLUTE MAXIMUM RATING : ( Ta = 25°C )

SYMBOL	PARAMETER	SUPER RED	UNIT
PAD	Power Dissipation Per Bar	60	mW
VR	Reverse Voltage Per Bar	5	V
IAF	Continuous Forward Current Per Bar	20	mA
—	Derating Linear From 25°C Per Bar	0.33	mA/°C
Topr	Operating Temperature Range	-35°C to 85°C	
Tstg	Storage Temperature Range	-35°C to 85°C	
Solder Temperature 1/16 inch Below Seating Plane for 3 Seconds at 250°C			

ELECTRO-OPTICAL CHARACTERISTICS : ( Ta = 25°C )

SYMBOL	PARAMETER	TEST CONDITION	MIN.	TYP.	MAX.	UNIT
VF	Forward Voltage , Per Bar	IF = 20mA		1.8	2.2	V
IR	Reverse Current , Per Bar	VR = 5V			100	µA
λP	Peak Emission Wavelength	IF = 20mA		660		nm
λD	Dominant Wavelength	IF = 20mA		643		nm
Δλ	Spectral Line Half – Width	IF = 20mA		20		nm
IV	Luminous Intensity Per Bar	IF = 10mA	3.2	8.0		mcd

FORWARD CURRENT Vs.  
FORWARD VOLTAGE

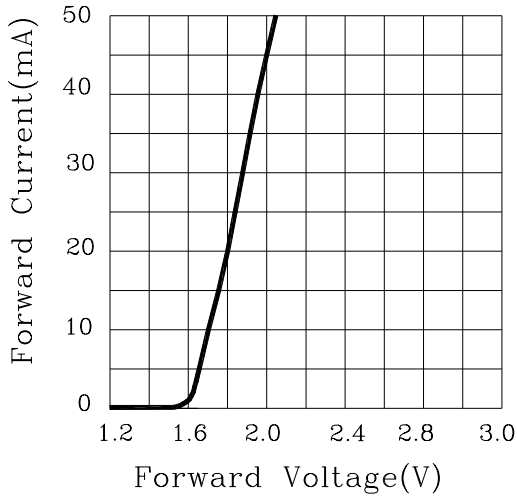

LUMINOUS INTENSITY Vs.  
FORWARD CURRENT

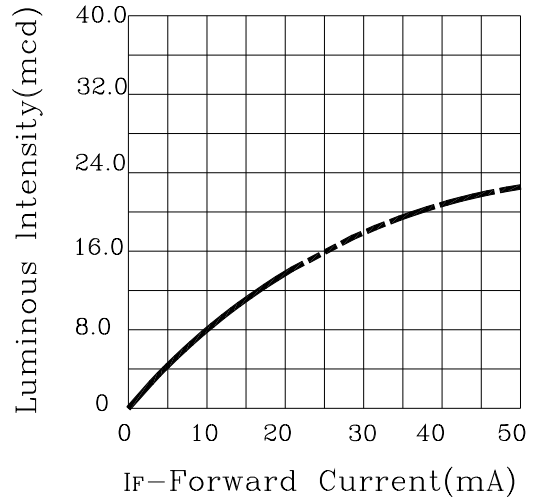

FORWARD CURRENT  
DERATING CURVE

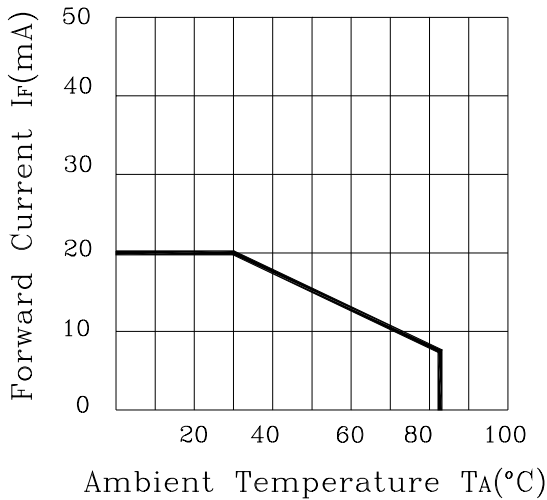

LUMINOUS INTENSITY Vs.  
AMBIENT TEMPERATURE

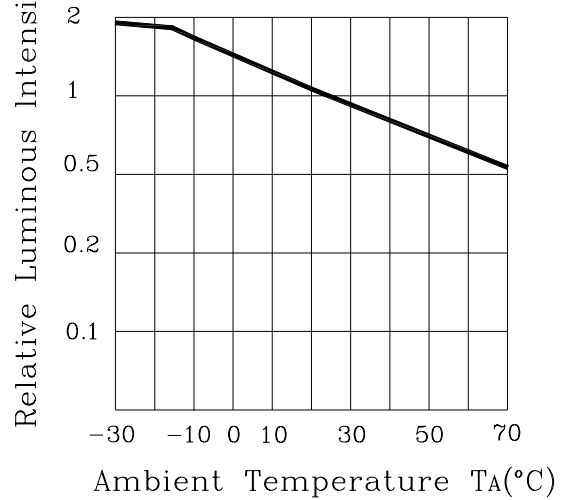

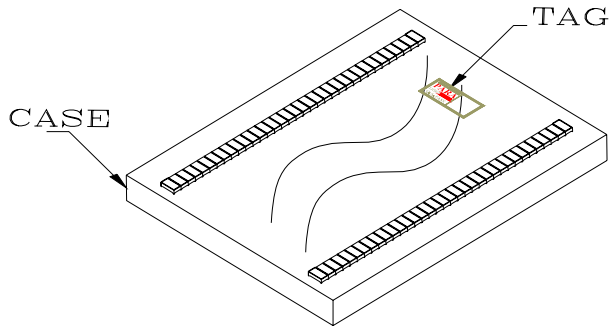

TAG (3:1)

420 PCS/PIECE

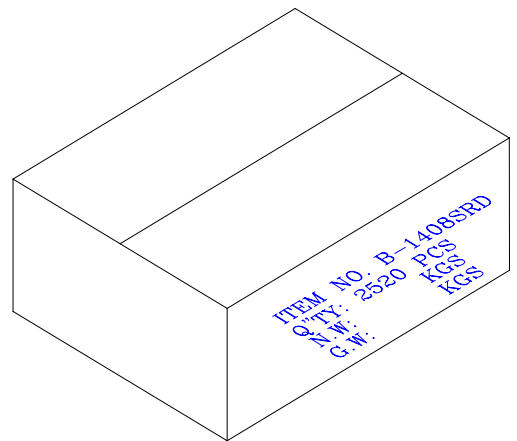
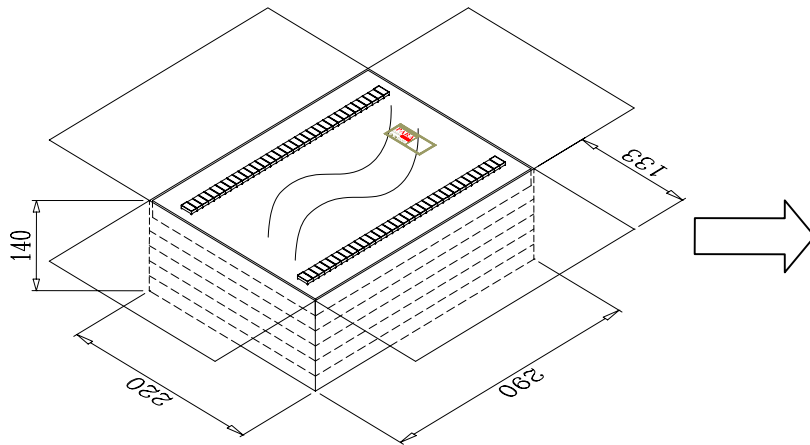

6 PIECE/BOX

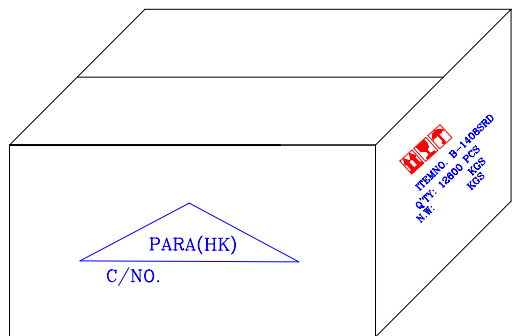
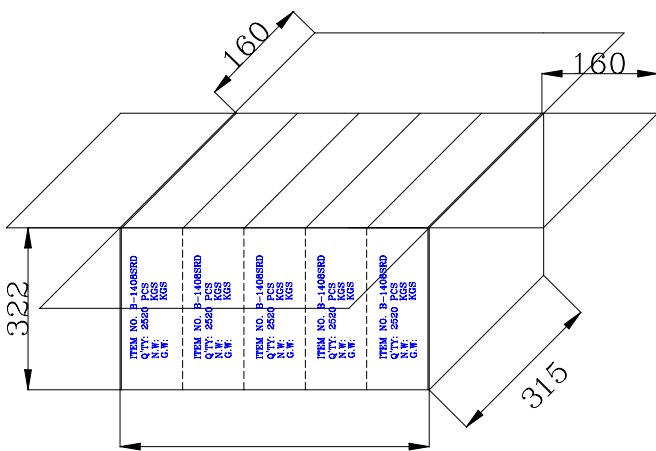

5 BOX/CTN

**Experiment Item:**

Item	Test Condition	Reference Standard
	Display	
OPERATION LIFE	<p>Ta : 25 ± 5°C                      IF : 10~20 mA PER SEGMENT                      TEST TIME :                      168HRS (-24HRS , +24HRS )                      500HRS (-24HRS , +24HRS )                      1000HRS (-24HRS , +72HRS )</p>	<p>MIL-STD-750 : 1026                      MIL-STD-883 : 1005                      JIS C 7021 : B-1</p>
HIGH TEMPERATURE HIGH HUMIDITY STORAGE	<p>Ta : 65°C ± 5°C                      RH : 90~95%RH                      TEST TIME : 240HRS ± 2HRS</p>	<p>MIL-STD-202 : 103B                      JIS C 7021 : B-1</p>
TEMPERATURE CYCLING	<p>85°C ~ 25°C ~ -35°C ~ 25°C                      30min 5min 30min 5min                      10CYCLES                      ( COB : Thot : 65°C Tcold : -25°C )</p>	<p>MIL-STD-202 : 107D                      MIL-STD-750 : 1051                      MIL-STD-883 : 1010                      JIS C 7021 : A-4</p>
THERMAL SHOCK	<p>85°C ± 5°C ~ -35°C ± 5°C                      10min 10min                      10CYCLES                      ( COB : Thot : 65°C Tcold : -25°C )</p>	<p>MIL-STD-202 : 107D                      MIL-STD-750 : 1051                      MIL-SYD-883 : 1011</p>
SOLDER RESISTANCE	<p>T , sol : 260°C ± 5°C                      DWELL TIME : 10 ± 1 sec</p>	<p>MIL-STD-202 : 210A                      MIL-STD-750-2031                      JIS C 7021 : A-1</p>
SOLDERABILITY	<p>T , sol : 230°C ± 5°C                      DWELL TIME : 5 ± 1 sec</p>	<p>MIL-STD-202 : 208D                      MIL-STD-750 : 2026                      MIL-STD-883 : 2003                      JIS C 7021 : A-2</p>

**•SOLDERING**

METHOD	SOLDERING CONDITIONS	REMARK
DIP SOLDERING	Bath temperature: 260±5°C Immersion time: within 5 sec	<ul style="list-style-type: none"> <li>Solder no closer than 2mm from the base of the package</li> <li>Using soldering flux, "RESIN FLUX" is recommended.</li> </ul>
SOLDERING IRON	Soldering iron: 30W or smaller Temperature at tip of iron: 260°C or lower Soldering time: within 5 sec.	<ul style="list-style-type: none"> <li>During soldering, take care not to press the tip of iron against the PIN. (To prevent heat from being transferred directly to the PIN.)</li> </ul>

1) When soldering the PIN of Display in a jig that the package is fixed with a panel (See fig.1), be careful not to stress the PIN with iron tip. When soldering Display in a condition that the package is fixed with a panel, be careful not to cling and stress the surface of Display on the panel to avoid damaging the Display.

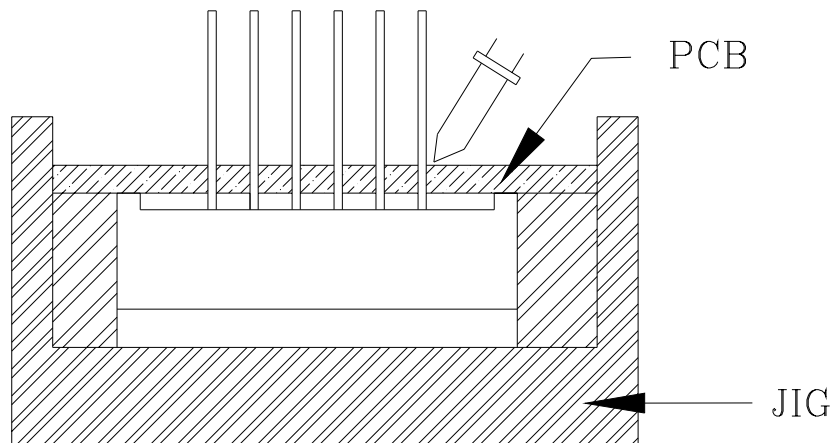

**Fig.1**

Regarding solution in the tinning oven for product-tinning, compound sub-solution made of tin & copper and silver is proposed with the temperature of Celsius 260. The proportion of the alloyed solution is tin 95.5: copper 3.5: silver 0.5 by percentage. The time of tinning is constantly 3 seconds.

- 2) Similarly, when a jig is used to solder the Display to PC board, take care as much as possible to avoid steering the PIN (See Fig.2).

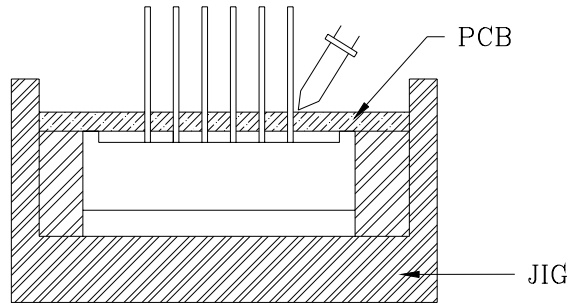

Fig.2

- 3) Repositioning after soldering should be avoided as much as possible. If inevitable, be sure to preserve the soldering conditions with irons stated above: select a best-suited method that assures the least stress to the Display.
- 4) PIN cutting after soldering should be performed only after the Display temperature has returned to normal temperature.

**•LED MOUNTING METHOD**

- 1) When mounting the Display by using a case, as shown Fig.3, ensure that the mounting holds on the PC board match the pitch of the PIN correctly-tolerance of dimensions of the respective components including the Display should be taken into account especially when designing the case, PC board, etc. to prevent pitch misalignment between the PIN and board holes, the diameter of the board holes should be slightly larger than the size of the PIN. Alternatively, the shape of the holes should be made oval. (See Fig.3)

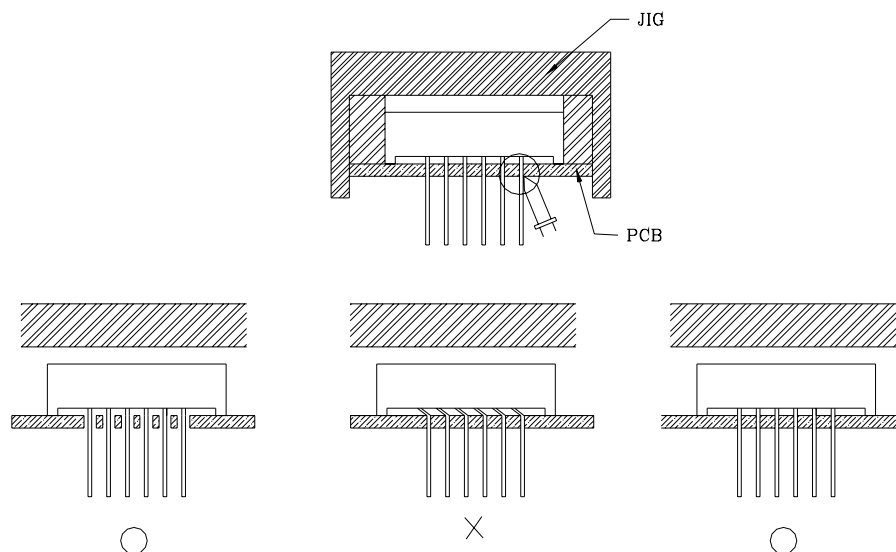

Fig.3



2) Use Display with holder made of resin (Fig.4) to position the PIN.

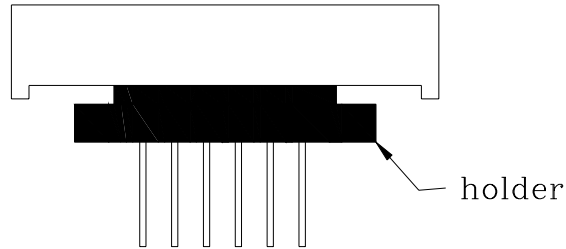

Fig.4

**•FORMED LEAD**

1) The PIN should be bent at a point located at least 2mm away from the package. Bending should be performed with base fixed means of a jig or pliers (Fig.5)

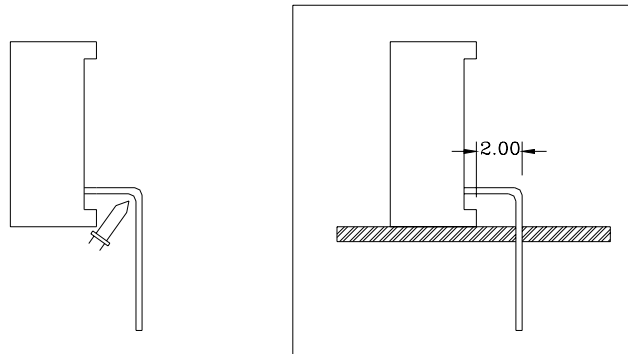

Fig.5

- 2) Forming PIN should be carried out prior to soldering and never during or after soldering.
- 3) Form the PIN to ensure alignment between the PIN and the hole on board, so that stress against the Display is prevented. (Fig.6)

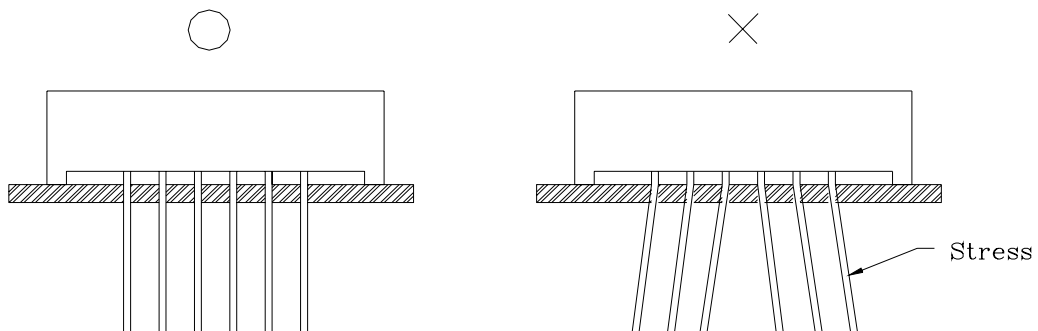

Fig.6

**•LEAD STRENGTH**

1) Bend strength

Do not bend the PIN more than twice. (Fig.7)

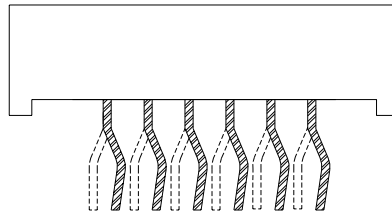

Fig.7

2) Tensile strength (@Room Temperature)

If the force is 1kg or less, there will be no problem. (Fig.8)

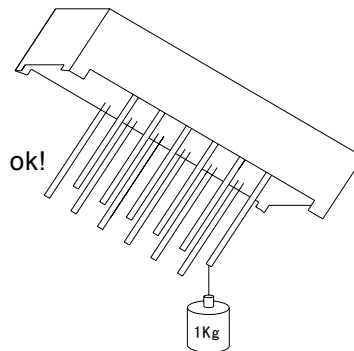

Fig.8

**•HANDLING PRECAUTIONS**

Although rigid against vibration, the Display may damaged or scratched if dropped. So take care when handling.

**•CHEMICAL RESISTANCE**

- 1) Avoid exposure to chemicals as it may attack the Display surface and cause discoloration.
- 2) When washing is required, refer to the following table for the proper chemical to be sued.

SOLVENT	ADAPTABILITY
Freon TE	⊙
Chlorothene	×
Isopropyl Alcohol	⊙
Thinner	×
Acetone	×
Trichloroethylene	×

⊙--Usable      ×--Do not use.

## X-ON Electronics

Largest Supplier of Electrical and Electronic Components

*Click to view similar products for [Standard LEDs - SMD category](#):*

*Click to view products by [Para Light manufacturer](#):*

Other Similar products are found below :

[LTST-C190KYKT](#) [LTST-C19GD2WT](#) [LTST-N683GBEW](#) [LTW-170ZDC](#) [LTW-M140SZS40](#) [LTW-M140ZVS](#) [598-8110-100F](#) [91-21SUBCS400-A6TR7](#) [AAAF5060QBFSEEZGS](#) [APT1608QGW](#) [EAST2012YA0](#) [99-213/R6C-AR2T1B/2C](#) [SML-LX0606SISUGC/A](#) [SML-LXR851SIUPGUBC](#) [LT1ED53A](#) [AM27ZGC03](#) [APFA3010SURKCGKQBDC](#) [APHK1608VGCA](#) [APT2012QGW](#) [LTST-008BGEW](#) [LTW-010DCG](#) [LTW-020ZDCG](#) [LTW-21TS5](#) [LTW-220DS5](#) [LO T67F-V1AB-24-1](#) [598-8330-117F](#) [CMDA20AYAA7D1S](#) [95-21SURCS530-A3TR10](#) [HSMQ-C177](#) [598-8040-100F](#) [598-8070-100F](#) [598-8140-100F](#) [598-8610-200F](#) [SML-LXL1209SYC/ATR](#) [CMD91-21VRC/TR7](#) [SML-512PWT86A](#) [SMF-2432GYC-TR](#) [EASV3015RGYA0](#) [LTST-C190KFKT-5A](#) [LTST-C194TBKT-5A](#) [CLX6E-FKC-CH1M1D1BB7C3D3](#) [SML-LXL0805USBC-TR](#) [SML-LX2835SYSUGCTR](#) [LTW-M670ZVS-M5](#) [APA2106ZGC/G](#) [CLMXB-FKA-CbcfghjnpACBB79463](#) [VFA1101W-5AY3B2-TR](#) [LCB P473-P2R2-3J7L-1-Z](#) [HSMR-C197](#) [LW A67C-S2U1-FK0KM0](#)