



PARA LIGHT ELECTRONICS CO., LTD.

4F, No.1, Lane 93, Chien Yi Road, Chung Ho City, Taipei, Taiwan, R.O.C.

Tel: 886-2-2225-3733

Fax: 886-2-2225-4800

E-mail: para@para.com.tw

<http://www.para.com.tw>

DATA SHEET

PART NO. : C403I-12

REV : A / 1

CUSTOMER'S APPROVAL : _____

DCC : _____

DRAWING NO. : DS-13-15-0173G

DATE : 2019-09-28

Page : 1

LD-R/RD012

0.40 INCH THREE DIGITS DISPLAY

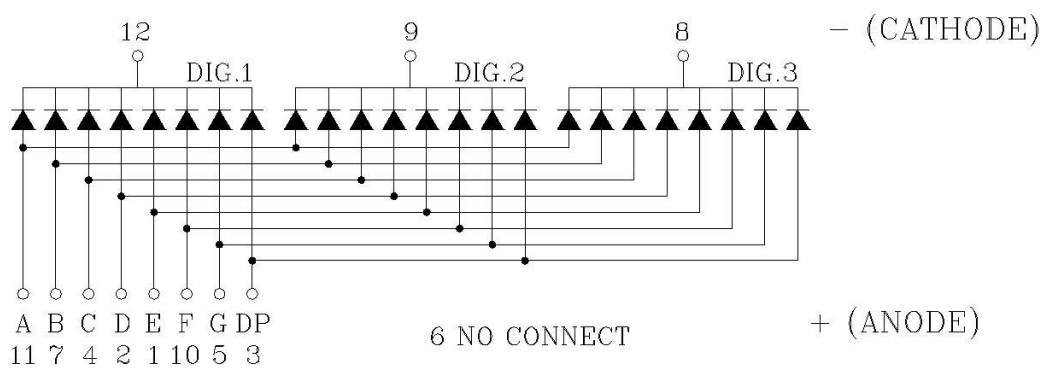
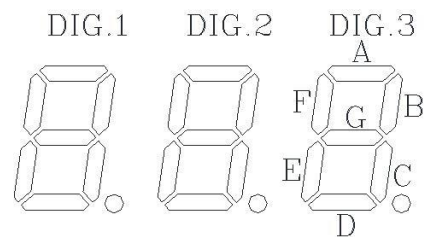
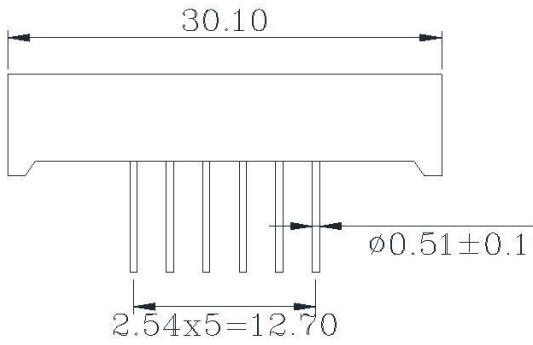
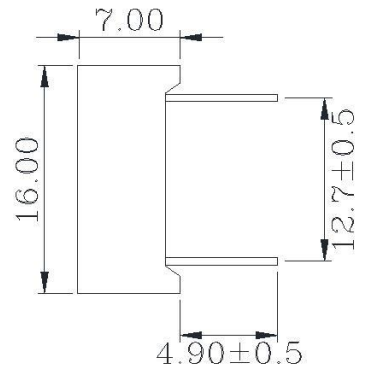
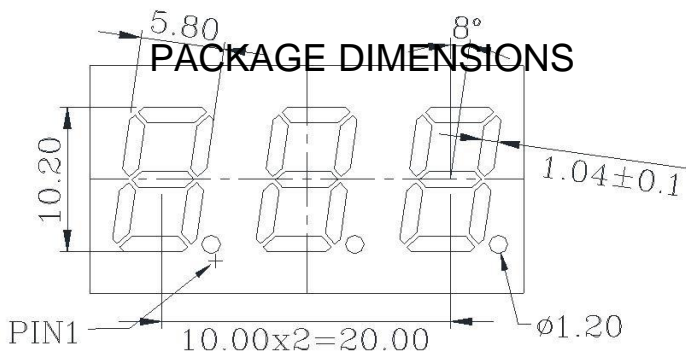

- NOTES :
1. All dimensions are in millimeters. (inches)
 2. Tolerance is $\pm 0.25(0.010)$ unless otherwise specified.
 3. Pls. contact with us when your production need to be operated under the Pb free process.



C403I-12

REV:A / 1

0.40 INCH THREE DIGITS DISPLAY

FEATURES

- 10.00mm (0.4 inch) DIGIT HEIGHT
- COMMON CATHODE
- I.C. COMPATIBLE
- LOW POWER CONSUMPTION
- Pb FREE PRODUCTS
- BLACK FACE, WHITE SEGMENTS

Raw Material : GaAlAs/GaAs			
ABSOLUTE MAXIMUM RATING : (Ta = 25°C)			
SYMBOL	PARAMETER	RED	UNIT
PD	Power Dissipation Per Segment	60	mW
VR	Reverse Voltage Per Segment	5	V
IAF	Continuous Forward Current Per Segment	30	mA
IPF	Peak Forward Current Per Segment (1/10 Duty Cycle,0.1ms Pulse Width)	100	mA
	Derating Linear From 25°C Per Segment	0.4	mA/°C

Topr Operating Temperature Range

-35°C to 85°C

Tstg Storage Temperature Range

-35°C to 85°C

ELECTRO-OPTICAL CHARACTERISTICS : (Ta = 25°C)

SYMBOL	PARAMETER	TEST CONDITION	MIN.	TYP.	MAX.	UNIT
VF	Forward Voltage , Per Segment	IF = 20mA		1.8	2.2	V
IR	Reverse Current , Per Segment	VR = 5V			100	µA
λP	Peak Emission Wavelength	IF = 20mA		660		nm
λD	Dominant Wavelength	IF = 20mA		643		nm
Δλ	Spectral Line Half—Width	IF = 20mA		20		nm
IV	Luminous Intensity Per Segment	IF = 10mA	2.4	6.0		mcd



C403I-12

REV:A / 1

0.40 INCH THREE DIGITS DISPLAY

FORWARD CURRENT Vs. FORWARD VOLTAGE

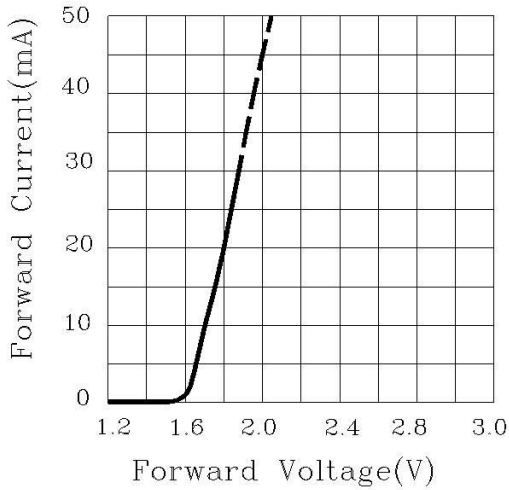

LUMINOUS INTENSITY Vs. FORWARD CURRENT

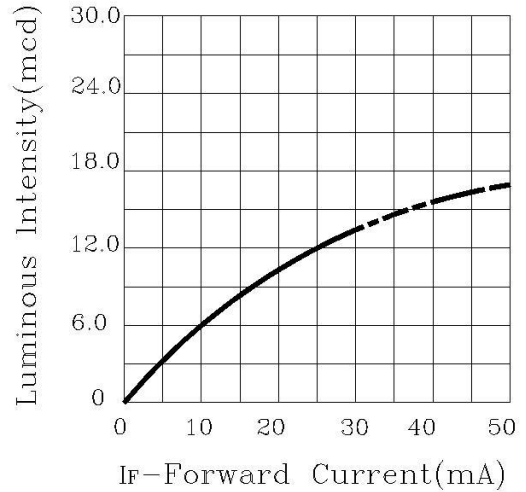

FORWARD CURRENT DERATING CURVE

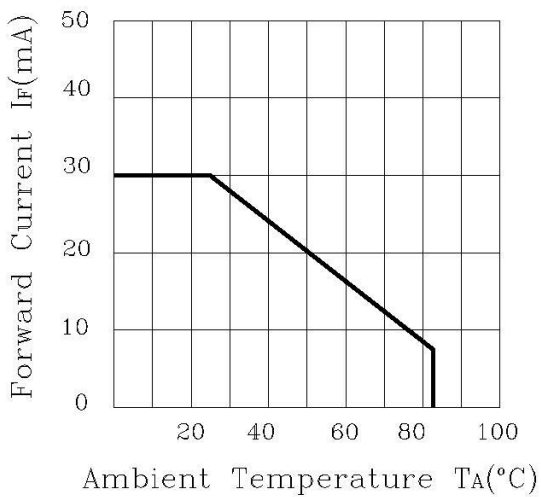

LUMINOUS INTENSITY Vs. AMBIENT TEMPERATURE

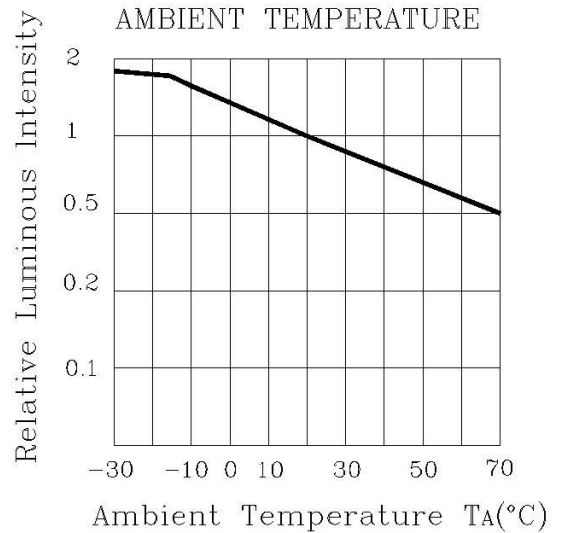

0.40 INCH THREE DIGITS DISPLAY

SOLDERING		
METHOD	SOLDERING CONDITIONS	REMARK
DIP SOLDERING	Bath temperature: 260 max Immersion time: within 5 sec	Solder no closer than 2mm from the base of the package Using soldering flux, "RESIN FLUX" is recommended. During soldering, take care not to press the tip of iron against the
SOLDERING IRON	Soldering iron: 30W or smaller Temperature at tip of iron: 260 or lower Soldering time: within 5 sec.	PIN. (To prevent heat from being transferred directly to the PIN.)

- 1) When soldering the PIN of Display in a jig that the package is fixed with a panel (See fig.1), be careful not to stress the PIN with iron tip. When soldering Display in a condition that the package is fixed with a panel, be careful not to cling and stress the surface of Display on the panel to avoid damaging the Display.

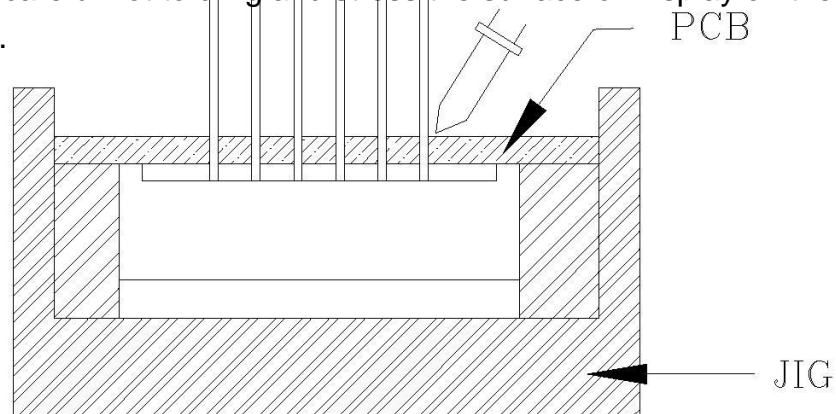

Fig.1

Regarding solution in the tinning oven for product-tinning, compound sub-solution made of tin & copper and silver is proposed with the temperature of Celsius 260. The proportion of the alloyed solution is tin 95.5: copper 3.5: silver 0.5 by percentage. The time of tinning is constantly 3 seconds.

X-ON Electronics

Largest Supplier of Electrical and Electronic Components

Click to view similar products for [LED Displays & Accessories](#) category:

Click to view products by [Para Light](#) manufacturer:

Other Similar products are found below :

[891-1G02-805](#) [LTC-2721WC](#) [LTC-4627G](#) [LTM-8522G](#) [LTS-3361JG-06](#) [LTS-7673GN](#) [HT-F196NB-5323](#) [SA03-12EWA](#) [LDQ-N514RI](#)
[LDS-A3506RD](#) [SI-B9T151550WW](#) [SI-B9V171550WW](#) [SLC-3PF-WL](#) [SLDN-32M-G](#) [1624](#) [LTC-2623WC](#) [LTC-4624P](#) [LTC-4627JD](#) [LTP-](#)
[1057AHR](#) [LTP-1457AKR](#) [LTP-3784G-01](#) [LTS-3361JS](#) [LTS-4812SKR-P](#) [LTS-6780P](#) [HV-7W30-6829](#) [DA43-11GWA](#) [LDQ-N3402RI](#)
[LDQ-N3606RI](#) [LDS-A3924RI-SI](#) [86004CB830](#) [LTP-3862JD](#) [LTP-2088AKD](#) [LTD-6740P](#) [LTC-4727E](#) [LTS-312AY](#) [LTC-2623E](#) [CC25-](#)
[12YWA](#) [OPS-S3911LY-GW](#) [LDF-U8004BI](#) [SLCN-42M-G](#) [SLCN-42M-W](#) [LTC-3710G](#) [LTS-4801KF](#) [ACSA04-41QWWA/D](#) [CA04-](#)
[41SURKWA](#) [OPS-S5620SB-GW](#) [MHDC2052SRBW](#) [MHDC4022UBBW](#) [FJ3101DH](#) [FJ3561AH](#)