



PARA LIGHT ELECTRONICS CO., LTD.

4F, No.1, Lane 93, Chien Yi Road, Chung Ho City, Taipei, Taiwan

Tel: 886-2-2225-3733

Fax: 886-2-2225-4800

E-mail: para@para.com.tw

<http://www.para.com.tw>

DATA SHEET

PART NO.: L-T2835WDT-CW0-CM

REV: A / 1

CUSTOMER'S APPROVAL : _____

DCC : _____

DRAWING NO. : DS-31P-16-0020

DATE :2018-05-23

PAGE

1 of 11

Features

- Ū Top view, Wide view angle, Warm White color PLCC 2 package SMD LED .
- Ū EIA STD package, packing in 8mm tape on 7" diameter reels (ANSI/EIA-481-B-2001).
- Ū Compatible with automatic Pick & Place equipment.
- Ū Compatible with IR Reflow soldering and TTW soldering.
- Ū Pb free product and acceptable lead-free process.
- Ū Meet RoHS Green Product.

Application

- * General lighting
- * Decorative and Entertainment Lighting.
- * Indicators.

Package Outline Dimensions

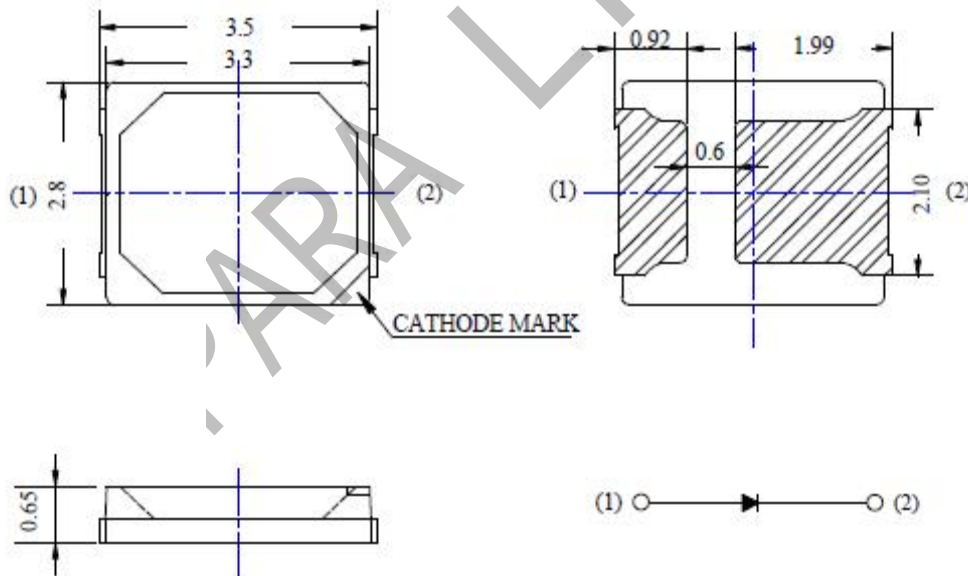

Notes:

1. All dimensions are in millimeters.
2. Tolerance is $\pm 0.20\text{mm}$ (.008") unless otherwise noted.



SURFACE MOUNT DEVICE LED

Part No. : L-T2835WDT-CW0-CM

REV: A / 1

Chip Materials

- Ū Dice Material : InGaN
- Ū Light Color : Natural White
- Ū Lens Color : Light Yellow Diffused.

Absolute Maximum Ratings(Ta=25°C)

Symbol	Parameter	Rating	Unit
P _D	Power Dissipation	300	mW
I _{PF}	Peak Forward Current (1/10 Duty Cycle, .1ms Pulse Width)	120	mA
I _F	Continuous Forward Current	90	mA
V _R	Reverse Voltage	5	V
ESD	Electrostatic Discharge Threshold (HBM) ^{Note A}	2000	V
Topr	Operating Temperature Range	-40 ~ + 85	°C
Tstg	Storage Temperature Range	-40 ~ + 100	°C

Note A :

HBM : Human Body Model. Seller gives no other assurances regarding the ability of to withstand ESD.

Electro-Optical Characteristics (Ta=25°C)

Parameter	Symbol	Min.	Typ.	Max.	Unit	Test Condition
Luminous flux(lm)	LM	17		23	lm	IF=60mA
Viewing Angle	2θ1/2		120		Deg	ote 2
Forward Voltage	VF	2.8		3.20	V	IF =60mA
Color Rending Index	CRI	75			Ra	IF=60mA
Chromaticity Coordinates	X	0.2247		0.2407		IF =60mA
	Y	0.1892		0.2102		IF=60mA

Relative Luminous Intensity Vs. Wavelength

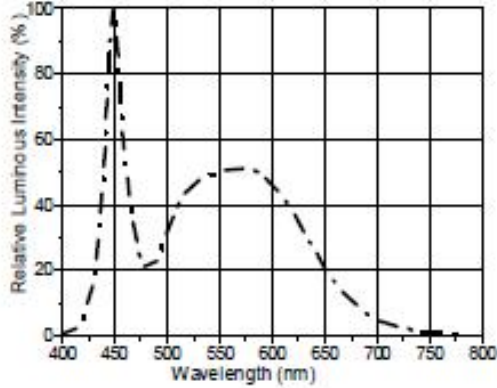

Forward Current vs Forward Voltage at Ta=25°C

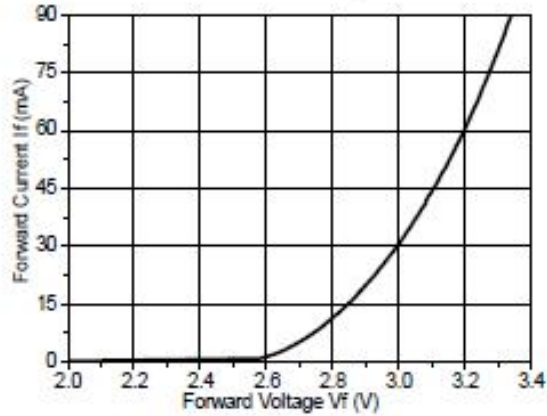

Forward Current Vs. Ambient Temperature

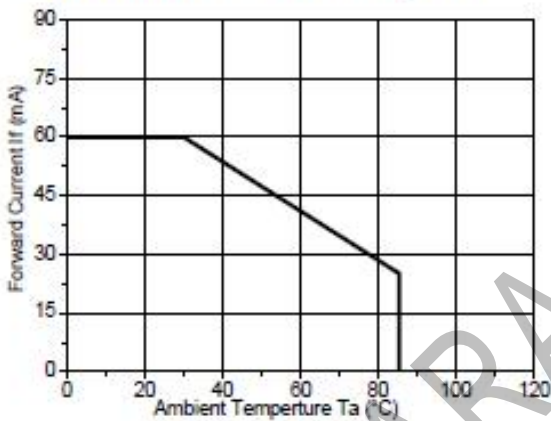

Forward Current Vs. Relative Luminosity Ta=25°C

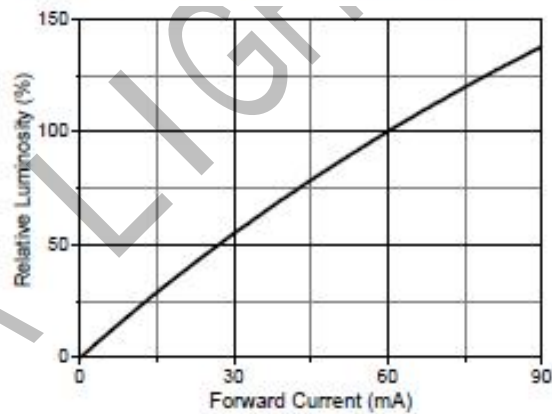

Relative Luminosity Vs. Ambient Temperature

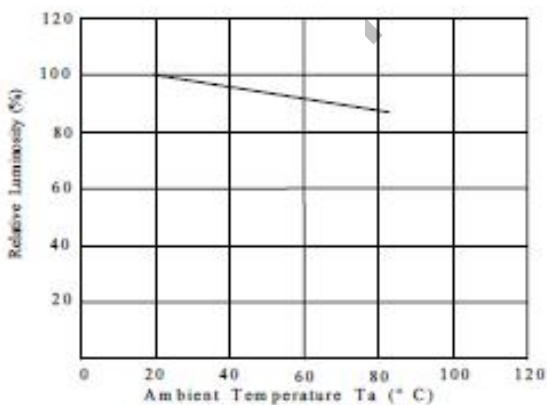

Radiation diagram

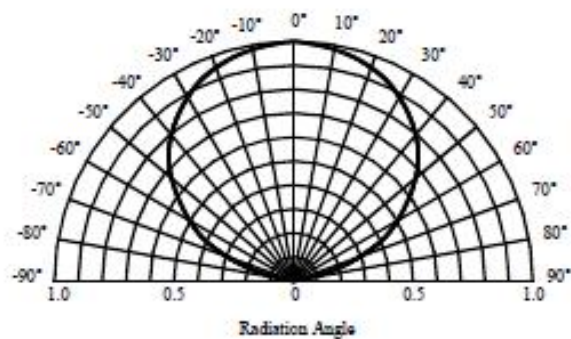



SURFACE MOUNT DEVICE LED

Part No. : L-T2835WDT-CW0-CM

REV: A / 1

I IV Bin Code List

Forward voltage (tolerance is $\pm 0.05V$ @ $I_F=60$ mA):

BIN CODE	Min. (V)	Max. (V)
R	2.8	2.9
S	2.9	3.0
T	3.0	3.1
U	3.1	3.2

Luminous Flux (tolerance is $\pm 10\%$ @ $I_F=60$ mA):

BIN CODE	Min. (Lm)	Max. (Lm)
L9	17	19
L10	19	21
L11	21	23
L12	23	25

X/Y IF=60mA

	O			
X	0.2407	0.2327	0.2247	0.2327
Y	0.2065	0.2102	0.1929	0.1892

C.I.E. Chromaticity Diagram

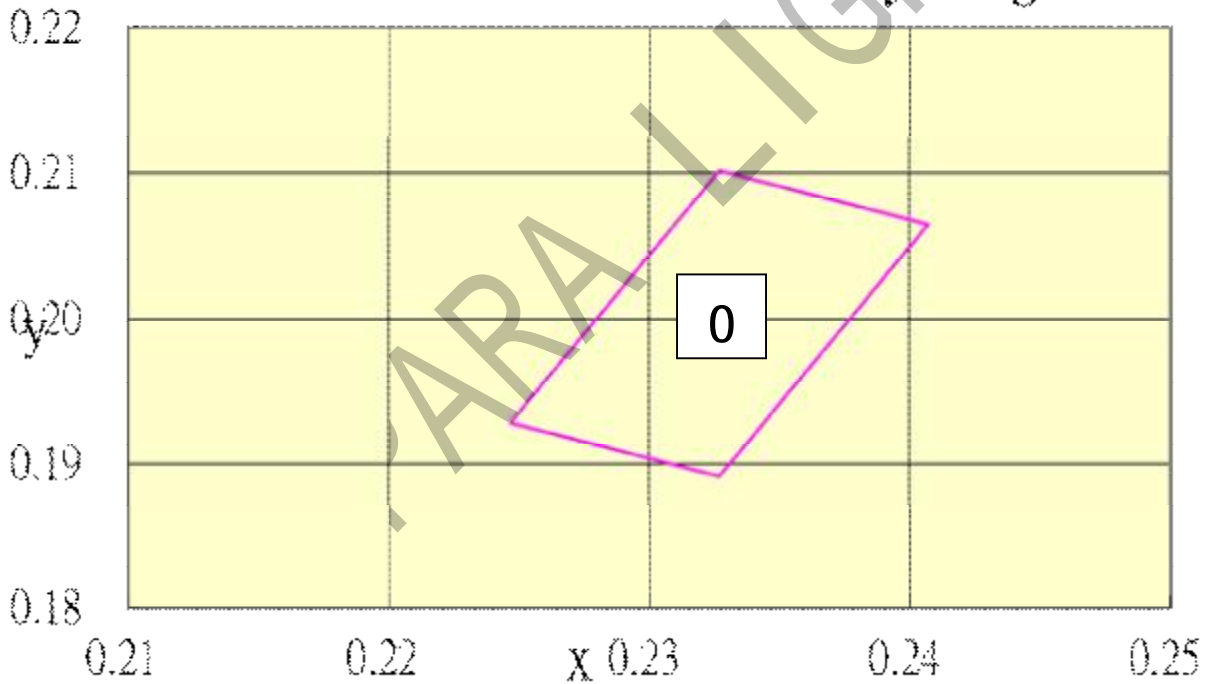

◆ Soldering Pad Dimensions

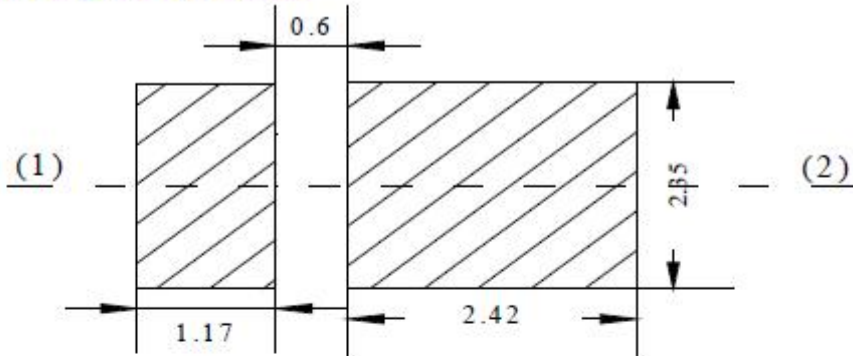

◆ Soldering Conditions (Maximum allowable soldering conditions)

Reflow soldering profile
 <Pb-free solder>

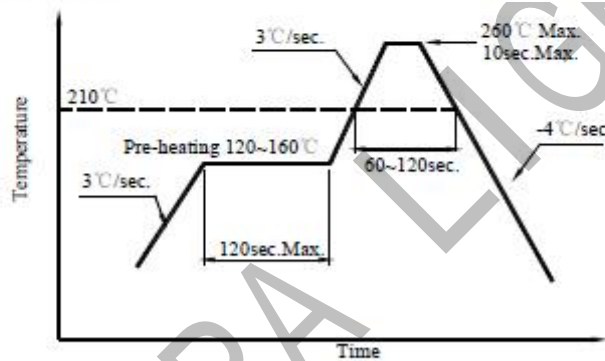

- Reflow soldering should not be done more than two times.
- Do not stress its resin while soldering.
- After soldering, do not warp the circuit board.
- Pay attention to electrostatic (ESD).

◆ Storage and application notices**1. Storage**

1. Calculated shelf life in sealed bag: 12 months at $<30^{\circ}\text{C}$ and $<90\%$ relative humidity (RH)
- 2.1 TOP LED: After bag is opened, devices that will be subjected to reflow solder or other high temperature process must be:
 - a) Mounted within: 168 hours of factory conditions $\leq 30^{\circ}\text{C}/60\%$ RH, or
 - b) Stored at ambient of $<20\%$ RH
- 2.2 CHIP LED: After bag is opened, devices that will be subjected to reflow solder or other high temperature process must be:
 - a) Mounted within: one year of factory conditions $\leq 30^{\circ}\text{C}/60\%$ RH, or
 - b) Stored at ambient of $<20\%$ RH.
3. Device require bake, before mounting, if:
 - a) Humidity indicator Card reads $>10\%$ when read at $25\pm 5^{\circ}\text{C}$
 - b) Above conditions are not metBaking condition: 24 hours at $60\pm 3^{\circ}\text{C}$ and $<5\%$ RH
4. The internal and esterand boxes can not be contacted with ground to prevent absorption of moisture;
5. No acid, alkali, salt, corrosive and explosive gas; away from sunlight and keep the environment clean;

2. Application

1. Do not use any unknown chemical liquid to clean LED, it will damage the LED resin surface; use the alcohol under the room temperature if necessary but less than 1 min, or use the ultrasonic cleaning with proper characters, such as correct power, frequency ,etc.
2. Do not touch the epoxy resin area when carrying LEDs by tweezers (as the following pictures), especially after the soldering process, the epoxy resin will turn to soft, the internal instruction will be damaged by the tweezers which cause the electric character's failure; nozzle is recommended by using SMT mounting.

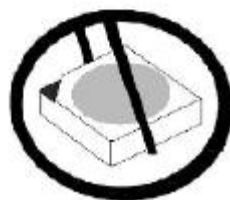

Correct



Incorrect

3. Soldering iron: double-side soldering iron with power of less than 25W; soldering temperature: less than 300℃; soldering time: less than 3sec.; 1 time completed is recommended, if the 2nd soldering process is requested, 3mins must be left to ensure the high temperature status can return to room temperature.
- a. REFLOW soldering: set and test the temperature of the different area of REFLOW equipment in advance.
- b. To set the peak temperature according to different SMDs, but the actual peak temperature should be less than 260℃, processing time should be less than 10sec, only 1 time is allowed.
4. SMDs should be soldered at the coordinated position on the PCB.
5. Note of Electrical matter:
- ① One-way conduction, LED does not allow the reverse driving.
 - ② LED is a kind of constant current component which can not be lighted by the constant voltage mode; a smaller voltage fluctuation can cause the large current fluctuation which causes the failure of LED.
Each LED should be drove under constant current mode if in a parallel circuit design, otherwise, the colour and brightness will be nonuniform; When the environmental temperature rising, the LED junction temperature will rise, internal resistance will decrease, so the current will be increased by the constant voltage power which short the life span.
 - ③ If the brightness of lighting source can meet the requirement, we recommend using the driving current less than the rated current, in order to improve the product's reliability.
6. LED is a kind of electrostatic sensitive devices, anti-static measures have to be processed during storage and operation:
- ① LED production workshop should lay anti-static floor and ground connection, the work table have to use the anti-static materials and cover a table mater with the surface resistance of $10^6-10^9\Omega$.
 - ② Production machine: REFLOW, SMT equipment, electric iron, test equipment; all the equipments must be well grounded, and the grounding alternating current impedance should be less than 1.0Ω . A fan need to be installed on the equipments and production processes that easy to generate static electricity; the operators must wear anti-static clothing, shoes, wristband, and gloves, etc. in the process.
 - ③ LEDs must be contained in the anti-static box, and all the package material should be the anti-static materials.



SURFACE MOUNT DEVICE LED

Part No. : L-T2835WDT-CW0-CM

REV: A / 1

7. The details electronic characters can refer to our product specification.

◆ Notes:

1. Above specification may be changed without notice. We will reserve authority on material change for above specification.

2. When using this product, please observe the absolute maximum ratings and the instructions for the specification sheets. We assume no responsibility for any damage resulting from use of the product which does not comply with the instructions included in the specification sheets.

PARA LIGHT

X-ON Electronics

Largest Supplier of Electrical and Electronic Components

Click to view similar products for [para light manufacturer](#):

Other Similar products are found below :

[UBL-3024-YW](#) [L-SC1R9PD1D1](#) [L3535UVC-K1PC](#) [LS115KRLGCT-20A](#) [L-C153PTDT-Lens-HD](#) [LT5050UVC-XPC](#) [B-1000G-GW](#) [L-C150WDT](#) [LT2835KYCT-BE1](#) [LS115JRJGCT-5A-UEI](#) [LT670KYCT](#) [L329EIR1C-UEI](#) [LT2835WDT-CW0-CM](#) [LC191IR1CT-HF](#) [L524EIR1C](#) [LC295JRLBCT](#) [LC195JRLBCT](#) [L-C170TBCT](#) [A-1001SRBW](#) [L-C175JRJGCT-AM](#) [L314EIR1C](#) [L-C150JRCT](#) [521110R1H-364-G](#) [LC191JGCT-5A](#) [L0001-4589](#) [L-C153CIR1CT-Lens-HD](#) [LT670LGCT](#) [LT670LBCT](#) [LC170WZDT](#) [LS110LGCT](#) [L-C292WDT-5A-YY](#) [L-513ED](#) [LS115JYLGCT](#) [L-C192CWDT-HM](#) [LS110LBCT](#) [LC195JYLGCT](#) [LC150JFCT](#) [LC195JGJYCT-GJ](#) [LC191JFCT-UEI](#) [LT2835IR1CT-150mA-HX](#) [LC295JYJGCT](#) [LC295KGGYCT](#) [L-C170JYCT](#) [L-5T47VB5C-D2-TR](#) [L-5T47LPG41C-D1](#) [L-513HURC](#)