

VGA-PS/2 Adapter Board Kit (#28075)

The VGA-PS/2 Adapter Board Kit makes it easy to add VGA, keyboard and mouse connections to any breadboard project or prototype. PS/2 type keyboards and mice are supported by this kit as well as standard VGA monitors. The VGA-PS/2 Adapter Board Kit was designed for use with the Propeller microcontroller, and the I/O connections are designed to line up with P16 through P27 on the Propeller chip. When using these I/O pins this board is directly compatible with the Keyboard, Mouse and VGA objects that are also used with the Propeller Demo Board. These objects are available in the Propeller Tool Library as well as on the Propeller Object Exchange.

Features

- SIP header makes breadboard connection easy
- Stacked connectors take up minimal space
- Kit form allows you to customize installation
- All surface-mount parts are in place; only soldering of through-hole components is required

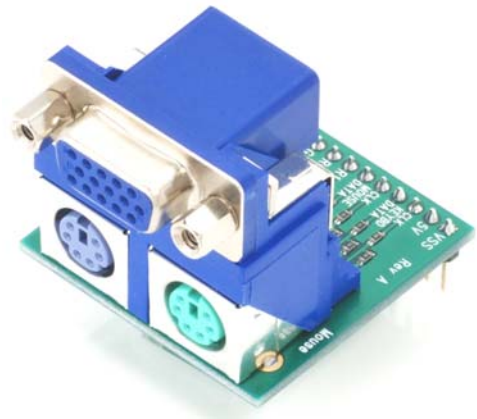

Key Specifications

- Power requirements: 5 VDC
- Power consumption: Determined by connected peripherals
- Interface (VGA): 2-bit DAC VGA signal
- Communication (PS/2): TTL synchronous serial interface (PS/2 keyboard & mouse)
- Operating temperature: 32 to 158 °F (0 to 70 °C)
- Dimensions: 1.50" L x 1.50" W x 1.65" H (38.10mm L x 38.10mm W x 41.92mm H)

Application Ideas

- Breadboard prototyping of projects requiring keyboard/mouse/VGA
- Panel mounting of VGA-PS/2 connectors

Kit Contents

- VGA-PS/2 Adapter Board PCB
- VGA-PS/2 connector assembly
- 14-pin SIP male-male header

Assembly Instructions

Step 1:

Locate the VGA-PS/2 connector assembly (left) VGA-PS/2 Adapter Board PCB (center) and 14-pin SIP header (right).

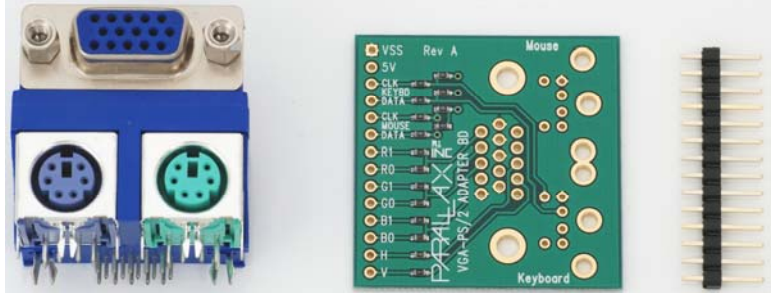

Step 2:

Very carefully install the connector assembly into the PCB as shown, taking care to make sure all pins are straight. Make sure that none of the pins were bent underneath the connector, but all are properly inserted into the PCB.

Once the connector is seated in the PCB you may solder the connector in place.

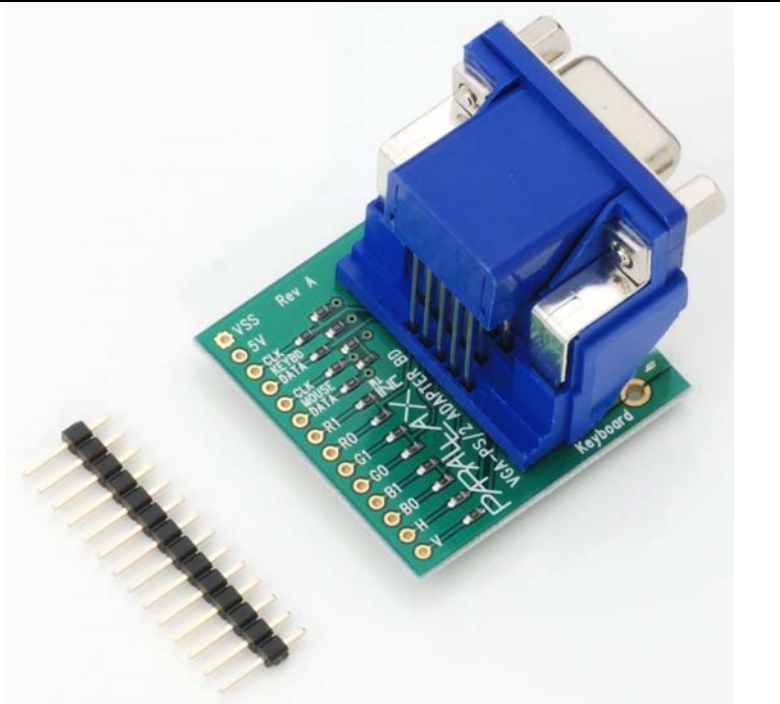

Step 3:

Take the 14-pin SIP Header and solder it in place so that the pins aim downward. In this manner the Adapter Board can be installed easily into a breadboard.

If you instead planned on soldering wires, a ribbon cable or some other connector you can do that here instead of using the included 14-pin SIP Header.

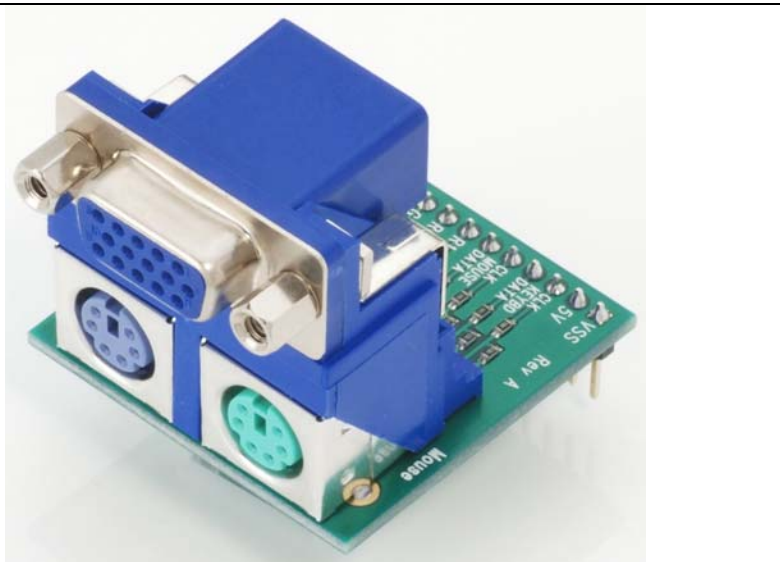

Quick-Start Circuit

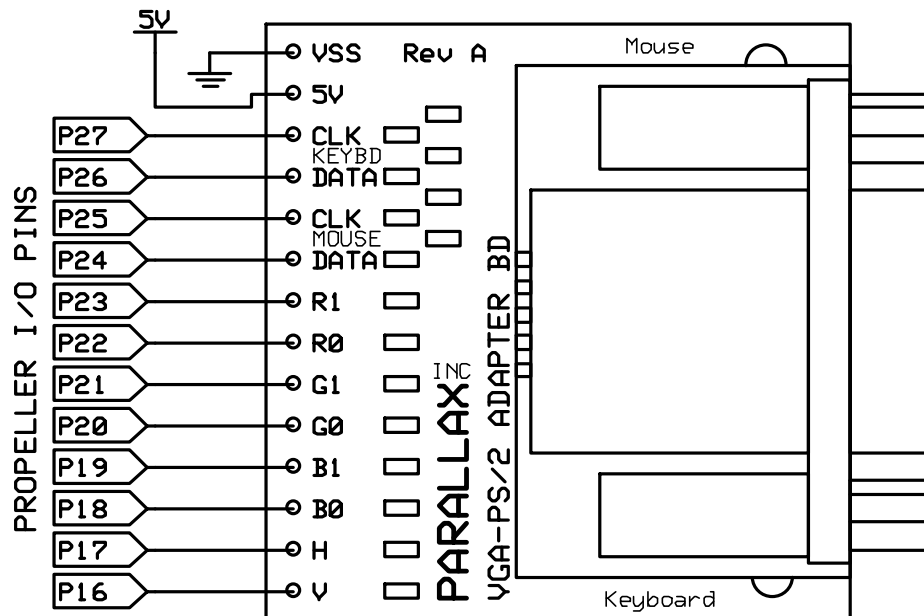

Figure 1: Connection Diagram

Connecting and Testing

Connect the pins above to the specified I/O pins on your Propeller Education Kit (#32305 or #32306), Propeller Proto Board (#32212 or #32812), Propeller Professional Development Board (#32111), PropRPM Board (#32202) or any other Propeller system. By using the pins listed above you can use the objects included in the Propeller Tool Library and Object Exchange to test the various peripherals on your Propeller system.

Downloads and Resources

You can obtain the Propeller Tool software from the Downloads link at <http://www.parallax.com/propeller>
You can obtain additional objects by visiting the object exchange at: <http://obex.parallax.com>

NOTES:

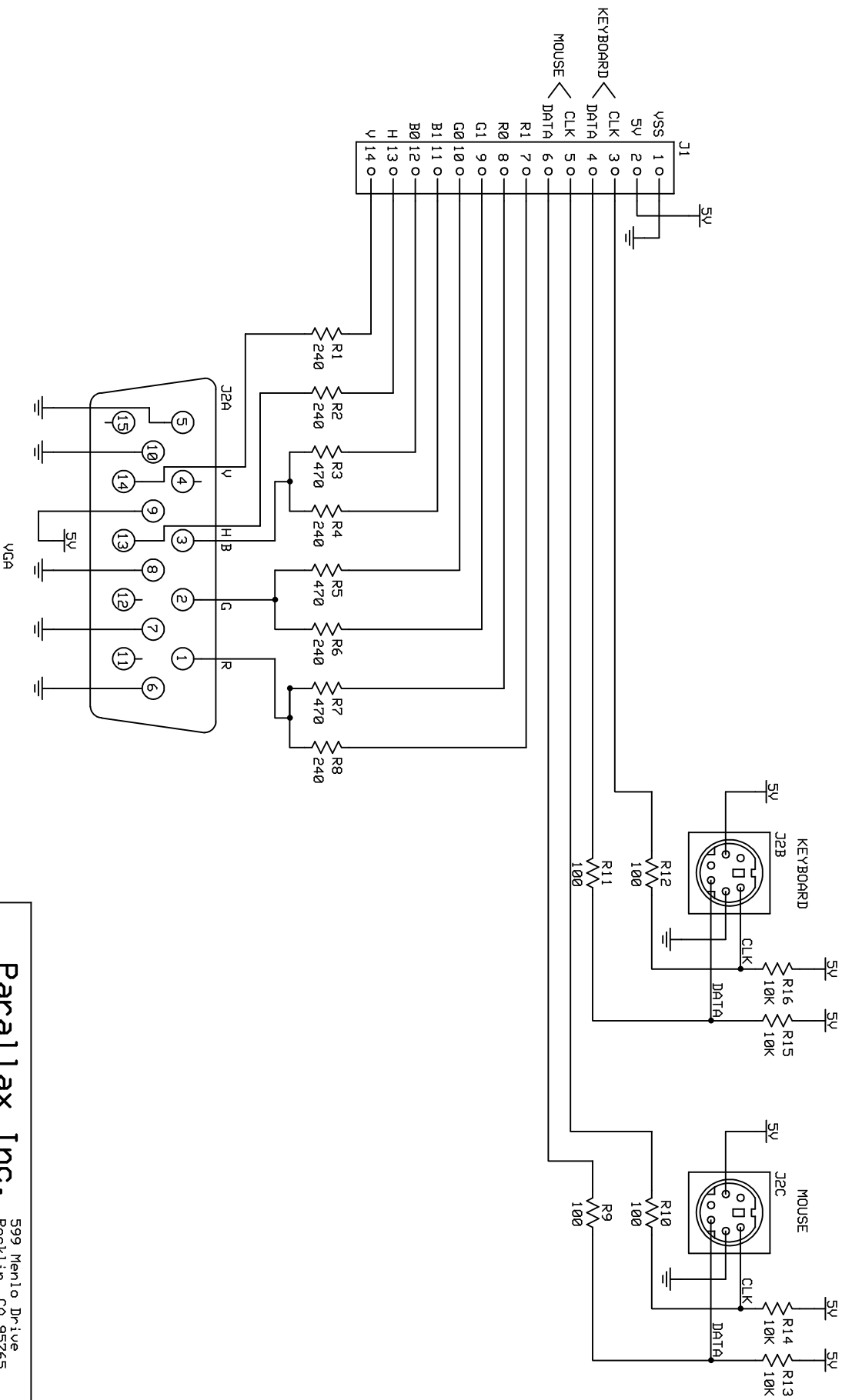

Parallax Inc. 599 Menlo Drive
 Rocklin, CA 95765

VGA-PS/2 Adapter Board

28075

Rev A
 04/16/2009

Page 1 of 1

X-ON Electronics

Largest Supplier of Electrical and Electronic Components

Click to view similar products for [Interface Development Tools](#) category:

Click to view products by [Parallax](#) manufacturer:

Other Similar products are found below :

[CY4607M](#) [DP130SSEVM](#) [ISO3086TEVM-436](#) [SP338EER1-0A-EB](#) [ADM00276](#) [ADP5585CP-EVALZ](#) [PEX8724-CA RDK](#) [PEX 8732-CA RDK](#) [PEX8747-CA RDK](#) [CHA2066-99F](#) [AS8650-DB](#) [MLX80104](#) [TESTINTERFACE](#) [I2C-CPEV/NOPB](#) [ISO35TEVM-434](#) [KIT33978EKEVB](#) [XR17D158CV-0A-EVB](#) [XR17V358/SP339-E4-EB](#) [XR18910ILEVB](#) [XR22804IL56-0A-EB](#) [ZSC31050KIT V3.1](#) [ZSC31150KIT V1.2](#) [SCRUBBER-EVM](#) [SI838XISO-KIT](#) [73931-3022](#) [XIO2200AEVM](#) [XIB-E](#) [XBIB-U-SP](#) [TW-DONGLE-USB](#) [EVAL-ADM2483EBZ](#) [EVAL-ADM2491EEBZ](#) [ATUSB-PCB-80146](#) [EVB-USB83340](#) [MAX9921EVKIT](#) [MAXREFDES23DB#](#) [MAX9291COAXEVKIT#](#) [MAX3535EEVKIT+](#) [MAX3100EVKIT](#) [MAX13235EEVKIT](#) [MAX14970EVKIT#](#) [MAX14826EVKIT#](#) [3298](#) [XR21B1424IV64-0A-EVB](#) [XR21B1421IL24-0A-EVB](#) [XTIB-U](#) [XR17D152CM-0A-EVB](#) [XR22802IL56-0A-EB](#) [9291COAXEVKIT#](#) [XTIB-R](#) [SERDESUR-43USBNOPB](#) [CMAXQUSB+](#)