

TECHNICAL DATA**MQ-7 GAS SENSOR****FEATURES**

- * High sensitivity to carbon monoxide
- * Stable and long life

APPLICATION

They are used in gas detecting equipment for carbon monoxide(CO) in family and industry or car.

SPECIFICATIONS

A. Standard work condition

Symbol	Parameter name	Technical condition	Remark
Vc	circuit voltage	$5V \pm 0.1$	Ac or Dc
V _H (H)	Heating voltage (high)	$5V \pm 0.1$	Ac or Dc
V _H (L)	Heating voltage (low)	$1.4V \pm 0.1$	Ac or Dc
RL	Load resistance	Can adjust	
RH	Heating resistance	$33 \Omega \pm 5\%$	Room temperature
T _H (H)	Heating time (high)	60 ± 1 seconds	
T _H (L)	Heating time (low)	90 ± 1 seconds	
PH	Heating consumption	About 350mW	

b. Environment conditions

Symbol	Parameters	Technical conditions	Remark
Tao	Using temperature	-20°C-50°C	
Tas	Storage temperature	-20°C-50°C	Advice using scope
RH	Relative humidity	Less than 95% RH	
O ₂	Oxygen concentration	21%(stand condition) the oxygen concentration can affect the sensitivity characteristic	Minimum value is over 2%

c. Sensitivity characteristic

symbol	Parameters	Technical parameters	Remark
Rs	Surface resistance Of sensitive body	2-20k	In 100ppm Carbon Monoxide
a (300/100ppm)	Concentration slope rate	Less than 0.5	Rs (300ppm)/Rs(100ppm)
Standard working condition	Temperature $-20^{\circ}\text{C} \pm 2^{\circ}\text{C}$	relative humidity $65\% \pm 5\%$	RL: $10K \Omega \pm 5\%$
	Vc: $5V \pm 0.1V$	VH: $5V \pm 0.1V$	VH: $1.4V \pm 0.1V$
Preheat time	No less than 48 hours	Detecting range: 20ppm-2000ppm carbon monoxide	

D. Structure and configuration, basic measuring circuit

Structure and configuration of MQ-7 gas sensor is shown as Fig. 1 (Configuration A or B), sensor composed by micro AL₂O₃ ceramic tube, Tin Dioxide (SnO₂) sensitive layer, measuring electrode and heater are fixed into a crust made by plastic and stainless steel net. The heater provides necessary work conditions for work of sensitive components. The enveloped MQ-7 have

6 pin ,4 of them are used to fetch signals, and other 2 are used for providing heating current.

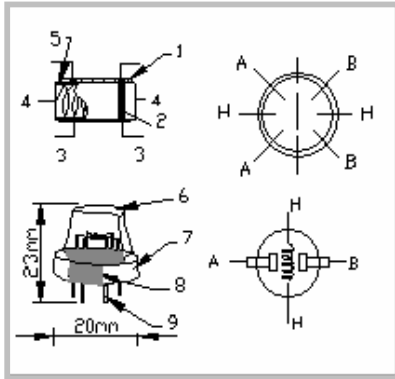

Parts	Materials
1 Gas sensing layer	SnO ₂
2 Electrode	Au
3 Electrode line	Pt
4 Heater coil	Ni-Cr alloy
5 Tubular ceramic	Al ₂ O ₃
6 Anti-explosion network	Stainless steel gauze (SUS316 100-mesh)
7 Clamp ring	Copper plating Ni
8 Resin base	Bakelite
9 Tube Pin	Copper plating Ni

Fig.1

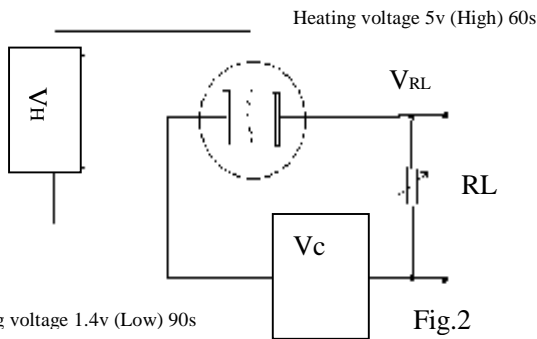
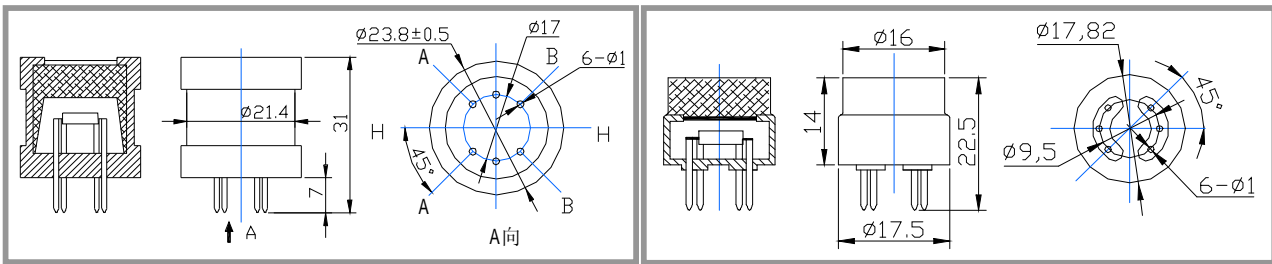

Standard circuit:

As shown in Fig 2, standard measuring circuit of MQ-7 sensitive components consists of 2 parts. one is heating circuit having time control function (the high voltage and the low voltage work circularly). The second is the signal output circuit, it can accurately respond changes of surface resistance of the sensor.

Electric parameter measurement circuit is shown as Fig.2

E. Sensitivity characteristic curve

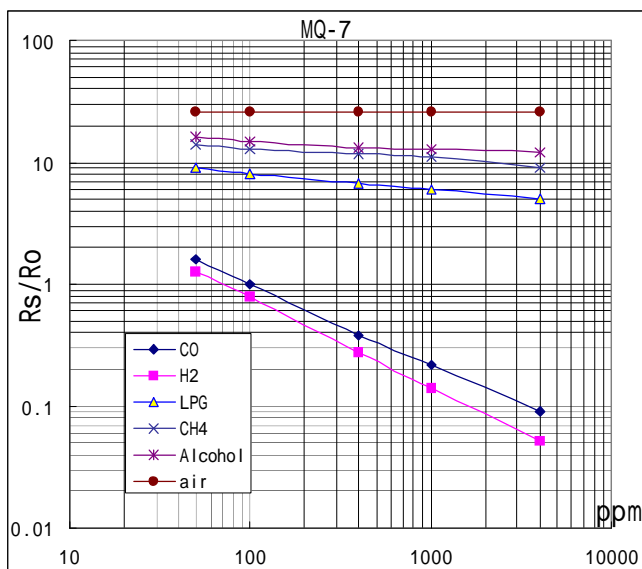

Fig.3 sensitivity characteristics of the MQ-7

Fig.3 is shows the typical sensitivity characteristics of the MQ-7 for several gases.

- in their: Temp: 20°C、
- Humidity: 65%、
- O₂ concentration 21%
- RL=10k Ω

Ro: sensor resistance at 100ppm CO in the clean air.

Rs: sensor resistance at various concentrations of gases.

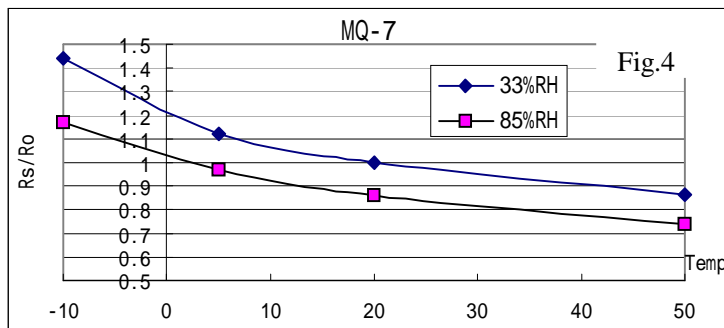

Fig.4 is shows the typical dependence of the MQ-7 on temperature and humidity.

Ro: sensor resistance at 100ppm CO in air at 33%RH and 20degree.

Rs: sensor resistance at 100ppm CO at different temperatures and humidities.

OPERATION PRINCIPLE

. The surface resistance of the sensor R_s is obtained through effected voltage signal output of the load resistance R_L which series-wound. The relationship between them is described:

$$R_s \setminus R_L = (V_c - V_{RL}) / V_{RL}$$

Fig. 5 shows alterable situation of R_L signal output measured by using Fig. 2 circuit output

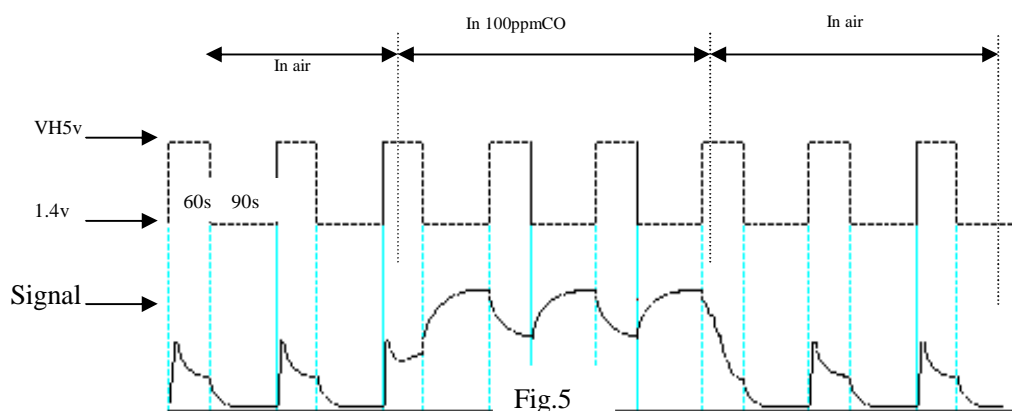

signal when the sensor is shifted from clean air to carbon monoxide (CO), output signal measurement is made within one or two complete heating period (2.5 minute from high voltage to low voltage).

Sensitive layer of MQ-7 gas sensitive components is made of SnO_2 with stability, So, it has excellent long term stability. Its service life can reach 5 years under using condition.

SENSITIVITY ADJUSTMENT

Resistance value of MQ-7 is difference to various kinds and various concentration gases. So, When using this components, sensitivity adjustment is very necessary. we recommend that you calibrate the detector for 200ppm CO in air and use value of Load resistance that(R_L) about $10 \text{ K } \Omega$ ($5 \text{ K } \Omega$ to $47 \text{ K } \Omega$).

When accurately measuring, the proper alarm point for the gas detector should be determined after considering the temperature and humidity influence. The sensitivity adjusting program:

- Connect the sensor to the application circuit.
- Turn on the power, keep preheating through electricity over 48 hours.
- Adjust the load resistance R_L until you get a signal value which is respond to a certain carbon monoxide concentration at the end point of 90 seconds.
- Adjust the another load resistance R_L until you get a signal value which is respond to a CO concentration at the end point of 60 seconds .

[Supplying special IC solutions, More detailed technical information, please contact us.](#)

X-ON Electronics

Largest Supplier of Electrical and Electronic Components

Click to view similar products for [Air Quality Sensors](#) category:

Click to view products by [Parallax](#) manufacturer:

Other Similar products are found below :

[GMS-MSTH2.S.V.3](#) [MO86571](#) [MO86561](#) [076074 01](#) [DE800.A.1](#) [MF010-2-LC1](#) [MF020-2-LC3](#) [KGZ10-5PIN](#) [GMS10SENSORS](#) [IR25TT](#)
[208280-0001](#) [IR11BD](#) [IR11GM](#) [IR12GM](#) [IR21BD](#) [GMS10-18C](#) [KGZ12](#) [S-300L-3V-5000-SLEEP-UART](#) [MP7227-TC](#) [OXY-LC-A25-455](#)
[SGPC3-TR-2.5KS](#) [T6713-6H](#) [POLOLU-1482](#) [3.000.475](#) [3.000.496](#) [HPMA115S0-XXX](#) [SGPC3-2.5k](#) [T3032-2-10K-24-P](#) [VQ6MB](#) [INIR-CD-](#)
[5%](#) [VQ23TB](#) [IR11GJ](#) [VQ31MB](#) [IR11BR](#) [GP2Y1026AU0F](#) [VQ549ZD](#) [MHM501-00](#) [MHM500-00A](#) [MHM305-01](#) [MICS-4514](#) [VQ548ZD-](#)
[S](#) [SEN-09403](#) [IR15TT](#) [MICS-5524](#) [MICS-5914](#) [MICS-2714](#) [INIR-ME-100%](#) [T8100-D](#) [VQ21TB](#) [IR21EJ](#)