

Dual Aluminum Stand PING))) Ultrasonic and Sharp IR Sensor Kit (#725-28915)

This aluminum bracket kit is designed for mounting a PING))) Ultrasonic Distance Sensor and either one of two popular Sharp IR Distance Sensors to your project.

The precision machined ¼" thick high-grade aluminum conveniently positions and protects the sensors in both stationary and mobile robotics applications. Assembly is quick and easy.



Features

- Fits the Parallax PING))) Sensor (#28015) and the Sharp GP2Y0A21YK0F IR Distance Sensor 10-80 cm (#28995) *or* the Sharp GP2Y0A02YK0F IR Distance Sensor 20-150 cm (#28997)
- This kit includes the PING))) sensor and GP2Y0A02YK0F IR Distance Sensor (#28997)
- Custom CNC-machined from 6061 high-grade aluminum
- Mounting hardware is included
- Dimensions: 2.58 x 2.72 x 0.90 in (6.35 x 6.91 x 2.29 cm)

Kit Contents

- (1) - PING))) Ultrasonic Distance Sensor (#28015)
- (1) - Sharp Long Distance IR Sensor (#28997)
- (1) - Dual IR/Ping Aluminum Protector Stand (#720-28007)
- (2) - Socket head 6-32 x ½" cap screws (710-00033)
- (4) - Pan Head screws, 4-40 x 1/2" (710-00006)
- (4) - Nylon spacers, round, #4 x 1/4" (#713-00005)
- (2) - Nylon spacers, round, #4 x 1/16" (#700-00015)
- (1) - Light Pipe (#720-28001)
- (1) - 7/64" Ball-End Hex Key (#725-00021)
- (1) - 3 wire Ext, F/F 12" cable (#800-00120)
- (1) - Sharp IR to Servo cable (805-28995)

Additional Parts & Tools Required

- Microcontroller of your choice to control and receive data from the sensors.

Assembly Instructions

Step 1: Plug the cables into the sensors.

Looking at the back (solder-side) of the IR sensor's PCB, the red wire should be on the left. The cable is polarized, and will only go on one way.

The PING))) sensor will have the black wire on the left-most pin of the three pin connector (labeled GND), when viewed from the sensor side of its board (see image, below).



Step 2: After you connect the 3-wire cable to the PING))), bend the connector/cable assembly to (approx.) a 45 degree angle as shown here...



The bending of the connector assembly provides the necessary space for the two sensors to be mounted in close proximity to each other.

Step 3: Place a 1/16" thick plastic washer onto each of the (2) Pan Head screws, and insert the screw through the backside of the PING))) printed circuit board (PCB).

Step 4: Now place two 1/4" plastic spacers onto the Pan Head screws and secure the PING))) sensor to the stand, thus spacing the PING))) PCB 1/4" out from the stand itself.



Step 5: Insert the light pipe through the hole in the top-center of the Dual Sensor Stand. Dab a tiny drop of Krazy™ glue on it to secure it more firmly (optional).

Step 6: Insert the IR Sensor into its (rectangular) hole and insert the two remaining ¼" tall plastic standoffs between the stand and the sensor tabs, using the two remaining Pan Head 4-40 screws.

Step 7: Mount the sensor assembly to your project with the two 6-32 x ½" socket-head screws (provided in the kit), using the ball-end 5/32" hex key – Parallax #725-00021 (included).

This completes the assembly of the Dual Sensor Stand.

Dimensional Drawings

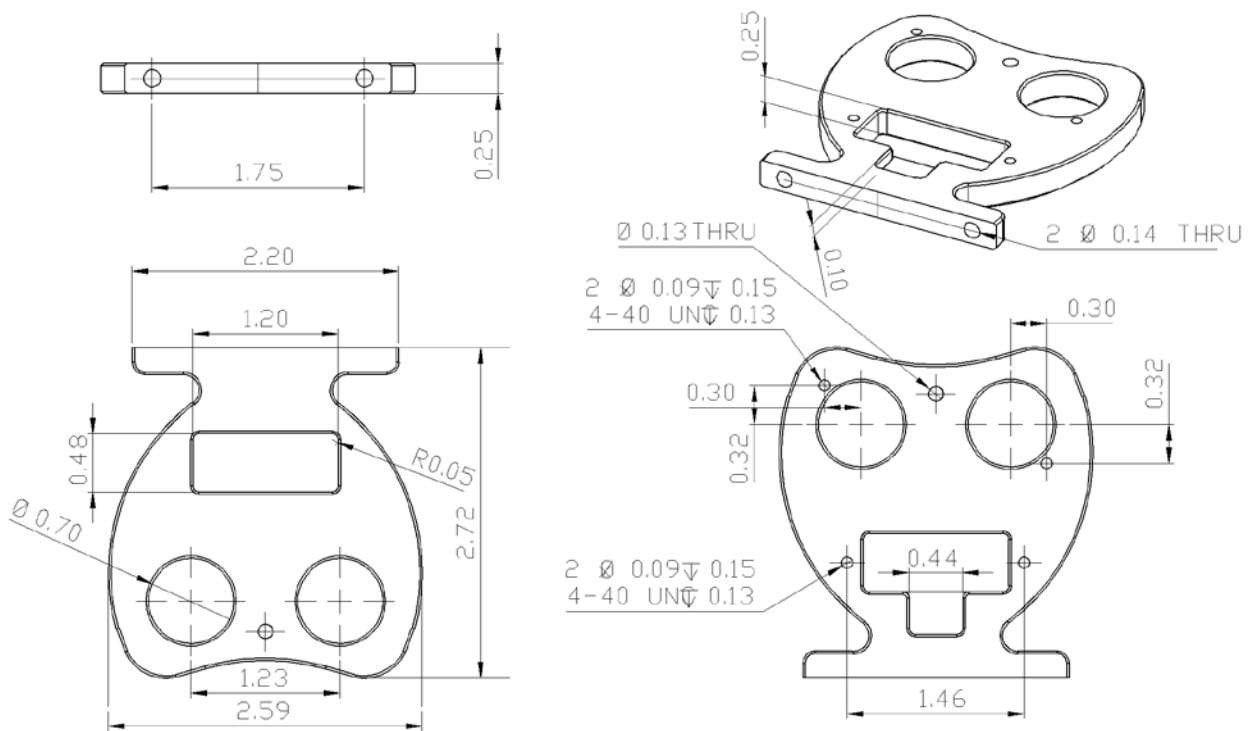

X-ON Electronics

Largest Supplier of Electrical and Electronic Components

Click to view similar products for [Optical Sensor Development Tools](#) category:

Click to view products by [Parallax](#) manufacturer:

Other Similar products are found below :

[AR0330CS1C12SPKAH3-GEVB](#) [MT9V034C12STCH-GEVB](#) [MT9V115EBKSTCH-GEVB](#) [416015300-3](#) [ISL29102IROZ-EVALZ](#)
[MT9M021IA3XTMH-GEVB](#) [AR1820HSSC12SHQAH3-GEVB](#) [AR1335CSSC11SMKAH3-GEVB](#) [MAXCAMOV10640#](#)
[MT9M031I12STMH-GEVB](#) [TSL2581CS-DB](#) [TMD3700-DB](#) [NANOUSB2.2](#) [ASX340AT3C00XPEDH3-GEVB](#) [AR0144ATSM20XUEAH3-GEVB](#) [AR0144CSSC00SUKAH3-GEVB](#) [AR0522SRSC09SURAH3-GEVB](#) [AR0522SRSM09SURAH3-GEVB](#) [AR0521SR2C09SURAH3-GEVB](#) [MARS1-MAX9295A-GEVK](#) [MARS1-MAX9296B-GEVB](#) [ISL29112IROZ-EVALZ](#) [AR0233AT2C17XUEAH3-GEVB](#)
[AR0431CSSC14SMRAH3-GEVB](#) [MARS-DEMO3-MIPI-GEVB](#) [TCS3430-DB](#) [AR0234CSSC00SUKAH3-GEVB](#) [AR0130CSSM00SPCAH-GEVB](#) [AR0330CM1C00SHAAH3-GEVB](#) [EVALZ-ADPD2212](#) [TMD2772EVM](#) [TMG3993EVM](#) [MIKROE-2103](#) [TSL2672EVM](#) [1384](#)
[MT9M114EBLSTCZDH-GEVB](#) [SEN0043](#) [SEN0162](#) [TMD2771EVM](#) [TMD3782EVM](#) [TSL4531EVM](#) [1918](#) [AS7225](#) [DEMO KIT](#) [SEN0097](#)
[SEN0228](#) [AR0134CSSC00SUEAH3-GEVB](#) [AP0100AT2L00XUGAH3-GEVB](#) [AR0144CSSM20SUKAH3-GEVB](#) [725-28915](#) [EVAL-ADPD1081Z-PPG](#)