

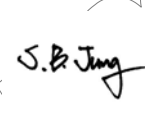

APPROVAL SHEET

PRODUCT NAME	SMD CRYSTAL UNIT		
FREQUENCY	27.1200MHz (10.0pF)		
USER PART NO.			
PARTRON MODEL	CXC5X271200CLVRB00		
CUSTOMER	Issued by	Checked by	Approved by
PARTRON	Issued by	Checked by	Approved by
	 J.S.B.	 M.N.S.	 K.J.M.
In Charge	J.S.B.	M.N.S.	K.J.M.
Division	R & D	Q C	R & D

MSL	LEAD FREE	Halogen-Free
MSL LEVEL 1		

※ Please return one copy with approval to PARTRON

2013. 11. 05

22-6, Seokwoo-dong, Hwaseong-si, Gyeonggi-do, Korea
 TEL : (031)201-7750

Contents

1. Revision History	- - - 3
2. Electrical characteristics	- - - 4
3. Mechanical characteristics	- - - 6
4. A Primary test result	- - - 7
5. Reliability test	- - - 8
6. Construction	- - - 9
7. Notices	- - - 10
8. Packing	- - - 11

Preiminary

1. Revision History

Rev.	Date	Rev. page	Revision Content and Reason	Remark
V1.0	'13.11.05	All Page	First-edition	

1. Scope

This document contains specifications related to **Crystal Unit**.

2. Electrical Characteristics

No.	Item	Symbol	Content
2.1	Frequency	f_0	27.1200 MHz
2.2	Frequency Tolerance 	$\Delta f/f_0$	± 30 ppm (@+25°C ± 2 °C)
2.3	Temperature range	Storage	T_{STG} -40 to 85°C
		Operating	T_{OPR} -40 to 85°C
2.4	Frequency stability	$\Delta f/f_0$	± 30 ppm
2.5	Drive level	DL	100 uW max.
2.6	Equivalent series resistance	R1	80 Ω max.
2.7	Oscillation mode	O/T	Fundamental
2.8	Shunt capacitance	CO	3.0 pF Max
2.9	Motional capacitance	C1	10.0 fF Max
2.10	Load capacitance	C_L	10.0 pF
2.11	Aging	f_a	± 5 ppm Max / year
2.12	Insulation resistance	IR	500 M Ω min @ 100VDC
[REMARK]			

2-1 Crystal Equivalent Circuit and Application Circuit

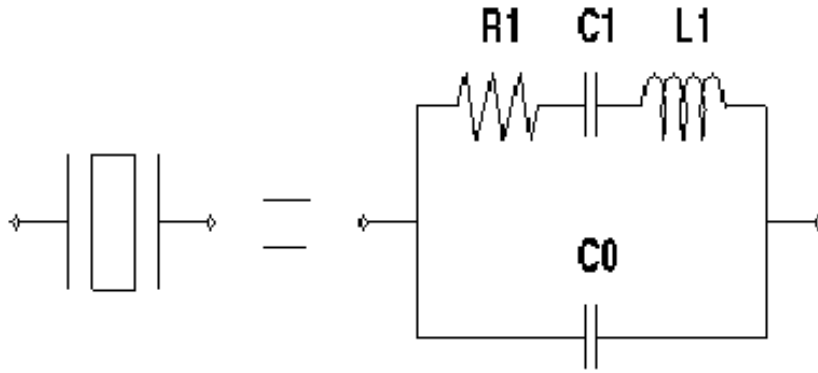

[Crystal and equivalent circuit]

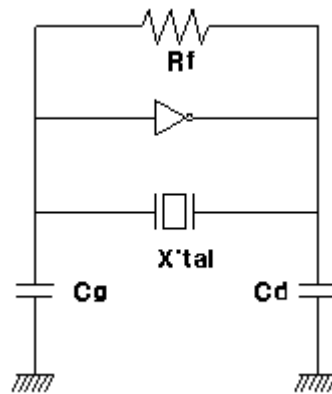

[Application circuit for oscillation]

3. Mechanical characteristics

3-1 Outline Dimensions and Pin connections

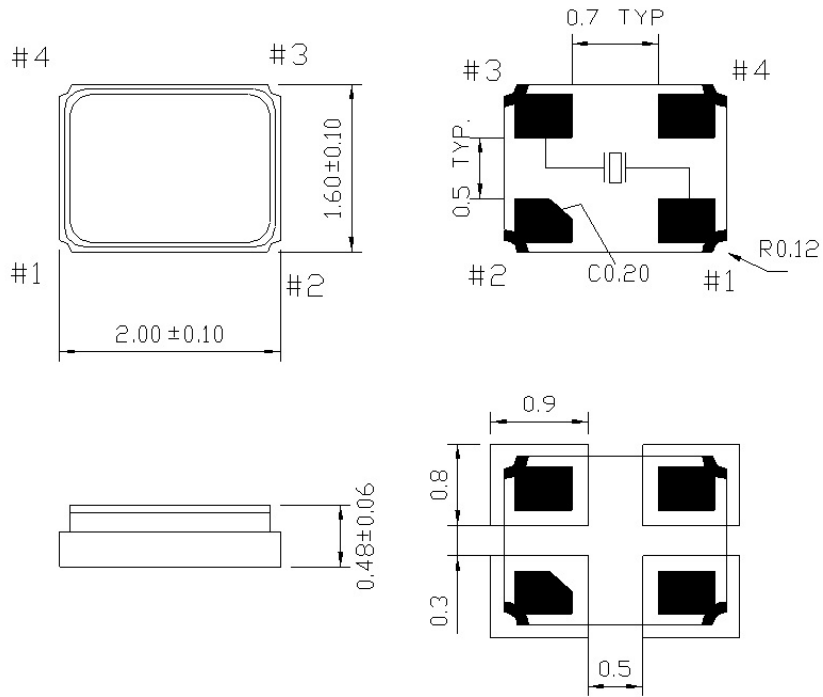

Pin connections	
#1	HOT
#2	GND
#3	HOT
#4	GND

[Recommended solder pad layout]

3-2 Marking and LOT No

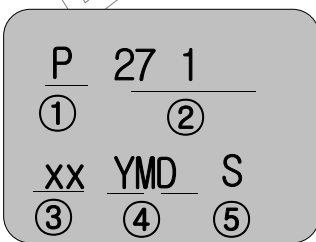

※Laser Marking

ITEM	MARKING	REMARK
①	P	Partron logo
②	27 1	Frequency: 27.1200MHz
③	XX	CRYSTAL CL
④	YMD	Y : the last 1 digit of year M : 1 digit of month (Jan to Sept; 1 to 9, Oct; A, Nov B, Dec; C) D : 1 digit of day 1 to 9, A to V (A=10, V=31) EX) 769 = 2007.06.09, 8AS = 2008.10.28
⑤	S	Manufacturing Site K .. Korea C .. China

4. A Primary test result

4-1 Electrical Characteristics Testing Data

No. \ Item	Result	FL (ppm)	C0 (pF)	R1 (Ω)	C1 (fF)	L (mH)	TS (ppm/pF)
Spec	High	30.0	3.0	80.0	10.0	-	-
	Low	-30.0	-	-	-	-	-
Max	Pass	-1.8	0.6	66.8	1.7	21.3	7.4
Min	Pass	-4.7	0.6	41.3	1.6	20.6	7.2
Average	Pass	-2.9	0.6	54.2	1.6	21.0	7.3
Stdev	Pass	1.1	0.0	8.4	0.0	0.2	0.1
1	Pass	-1.9	0.6	45.0	1.6	21.3	7.2
2	Pass	-4.7	0.6	41.3	1.7	20.7	7.4
3	Pass	-3.3	0.6	53.8	1.6	20.9	7.3
4	Pass	-2.6	0.6	61.5	1.7	20.8	7.4
5	Pass	-3.6	0.6	66.8	1.6	21.1	7.2
6	Pass	-1.8	0.6	54.3	1.6	21.1	7.2
7	Pass	-2.9	0.6	46.8	1.6	21.1	7.2
8	Pass	-1.8	0.6	53.9	1.7	20.9	7.3
9	Pass	-4.3	0.6	53.9	1.6	21.3	7.2
10	Pass	-1.9	0.6	65.1	1.7	20.6	7.4

Preliminary

5. Reliability test

5.1 Environment Test

Contents	Condition	Remark
High temperature Storage	+125°C±5°C, 240 hr	*Testing is complete, leave at room temperature for 24 hours, and Measure.(25°C±5°C) * Be satisfied with contents No 2. Specification
Low temperature Storage	-55°C±5°C, 240 hr	
High temperature High humidity Storage	+85°C±5°C, RH=85%, 96 hr	
PCT	+121°C±5°C, RH=100%, 24hr	

5.2 Thermal shock , Reflow Test

Contents	Condition	Remark
Thermal shock	-40°C±5°C,+85°C±5°C, 30 min, 32 cycle	*Testing is complete, leave at room temperature for 24 hours, and Measure.(25°C±5°C) * Be satisfied with contents No 2. Specification
REFLOW	Pre Heating 200±5°C , 30~60 sec Peak Heating 260°C±5°C , 30sec Max	

5.3 Mechanical Test

Contents	Condition	Remark
Vibration	Frequency : 10~500Hz, 10 x9.8m/s ² (G) Sweep time 15min ,X.Y.Z each 5 times	*Testing is complete, leave at room temperature for 1 hours, and Measure.(25°C±5°C) * Be satisfied with contents No 2. Specification
Drop test	12 times falling at a 152cm height (falling with jig)	

5.4 Table

Frequency change permitted	±3ppm Max.
----------------------------	------------

6. Soldering Condition

6.1 Standard Reflow soldering condition

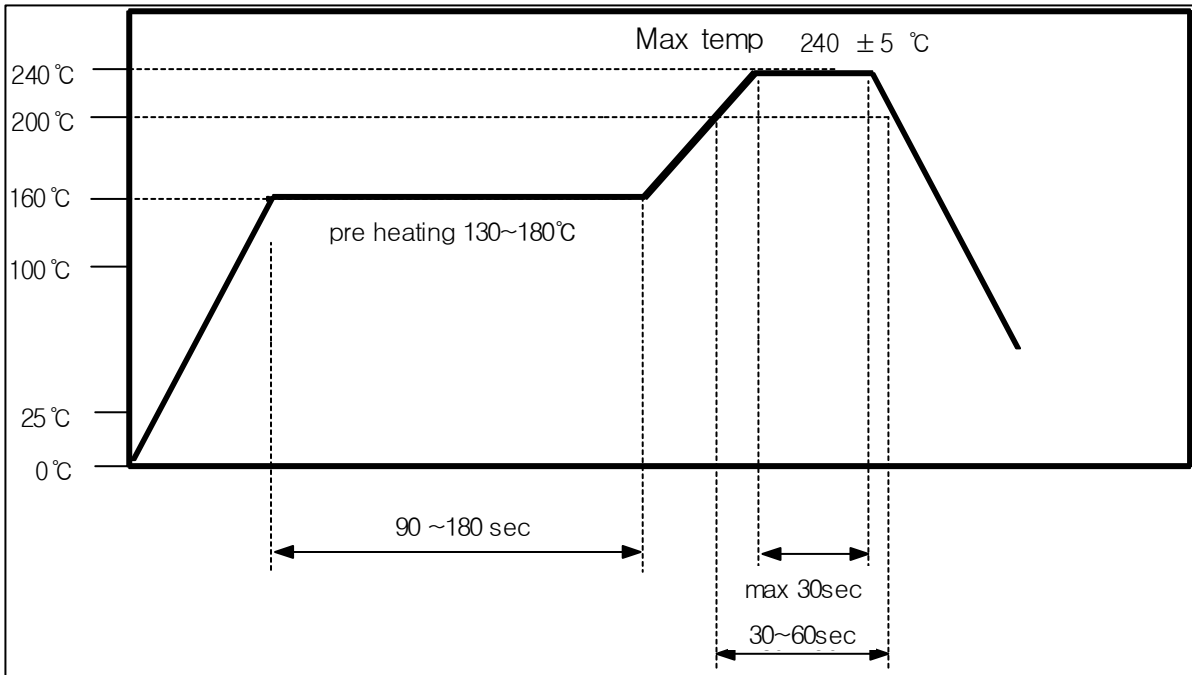

6.2 The maximum temperature guarantees to the 260°C(10sec Max)

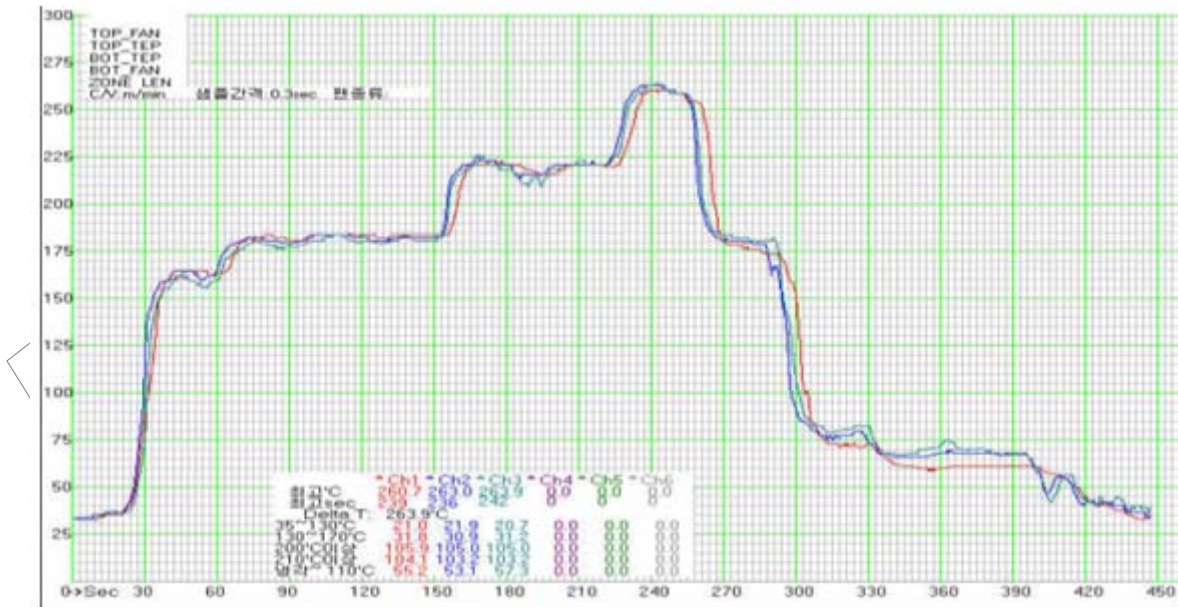

6.3 Soldering Iron Method

- Pre heating : 120°C (30 ~ 300 sec)
- Max temp : 410°C Max
- Time : Max 4 sec

7. Construction

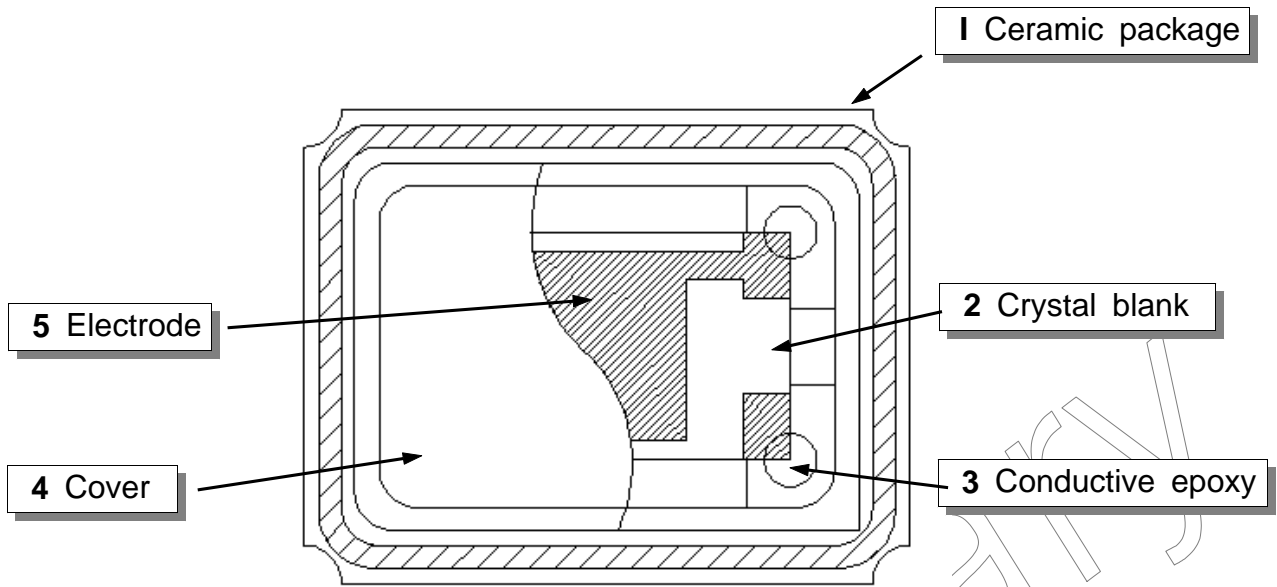

No	item
1	Ceramic package
2	Crystal blank
3	Conductive Epoxy
4	Lid(Cover)
5	Electrode

8. Notices

8-1 Max. two(2) times reflow is allowed.

Once miss soldering is happen, hand work soldering by soldering iron is recommended.
(+400°C x within 5 sec)

8-2 Ultrasonic vibration may cause deterioration and destruction of the components.

Please avoid ultrasonic cleaning

8-3 We recommend storing products at +15°C to +35°C and 25% R.H to 75% R.H

8-4 ESD Level : Class2(2000V ~ 4000V)

8-5 MSL LEVEL 1 (JEDEC J-STD-020C)

ITEM	Floor Life		Soak Requirements	
	Time	Conditions	Time	Conditions
1	Unlimited	=< 30°C/85%RH	165+5/-0	=< 85°C/85%RH

8-6 Unless adequate negative resistance is allocated in the oscillation circuit, start up time of oscillation may be increased, or no oscillation may occur. In order to avoid this, please provide enough negative resistance in the circuit design.

◎ How to check the negative resistance

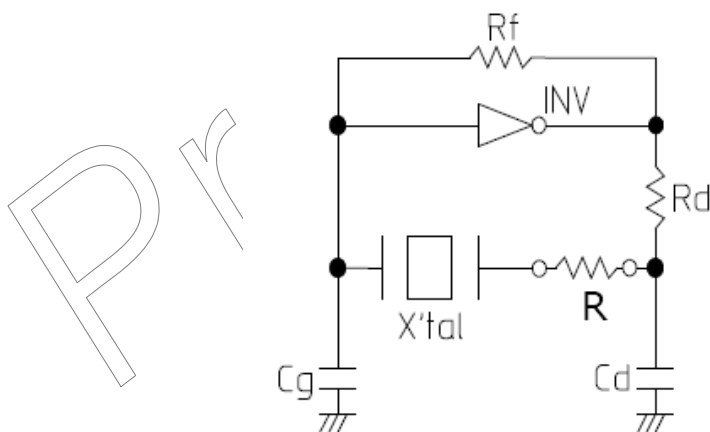

(1) Connect the resistor (R) to the circuit in series with the crystal resonator.

(2) Adjust R so that oscillation can start (or stop).

(3) Measure R when oscillation just start (or stop) in above (2).

(4) Get the negative resistance

$$-R = R + CI \text{ value}$$

(5) Recommended -R

$$[-R] > CI \times 5$$

9. Packing

9.1 Reel, carrier tape material

item	Main Material
Cover Tape	PE (Polyester film)
Carrier Tape	PC (Poly Carbonate +Carbon) or (Clear Poly Carbonate)
Reel	PS (Poly Styrene)

9.2 inner Box :1 reel/inner box and 2,000 pcs/1 reel.

9.3 Outer Box : 10 inner boxes/Outer Box

Total 20,000 pcs are packed in a 1 outer box

9.4 Reel and Carrier tape dimensions(unit : mm)

■ Carrier tape

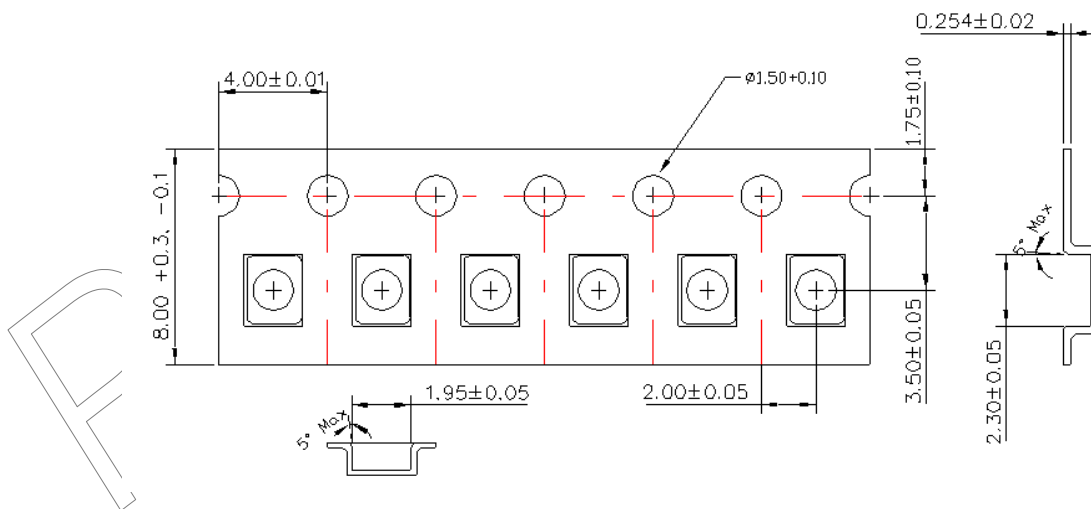

*Heating press cover tape

9.5 Reel Dimensions (unit : mm)

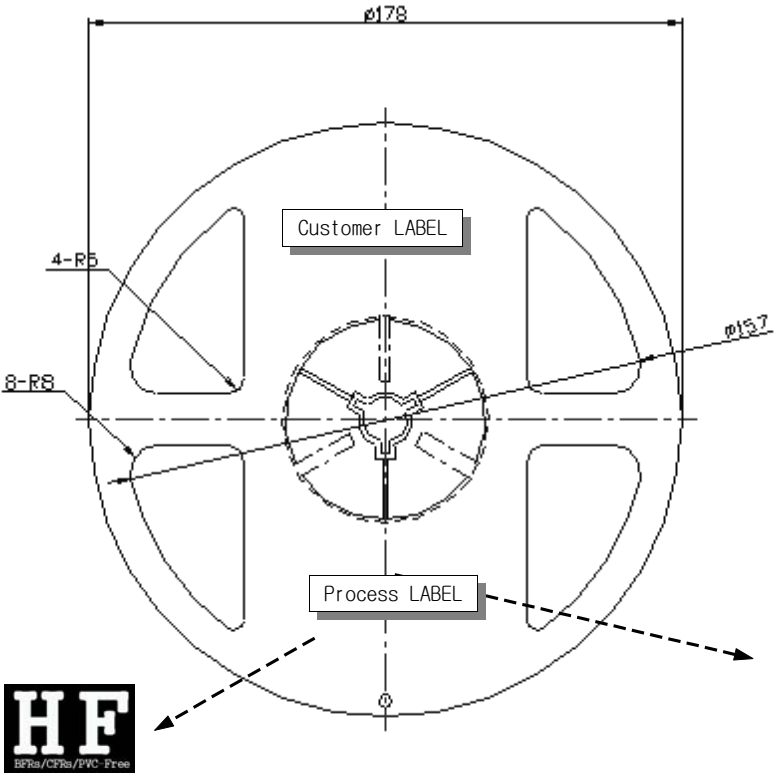
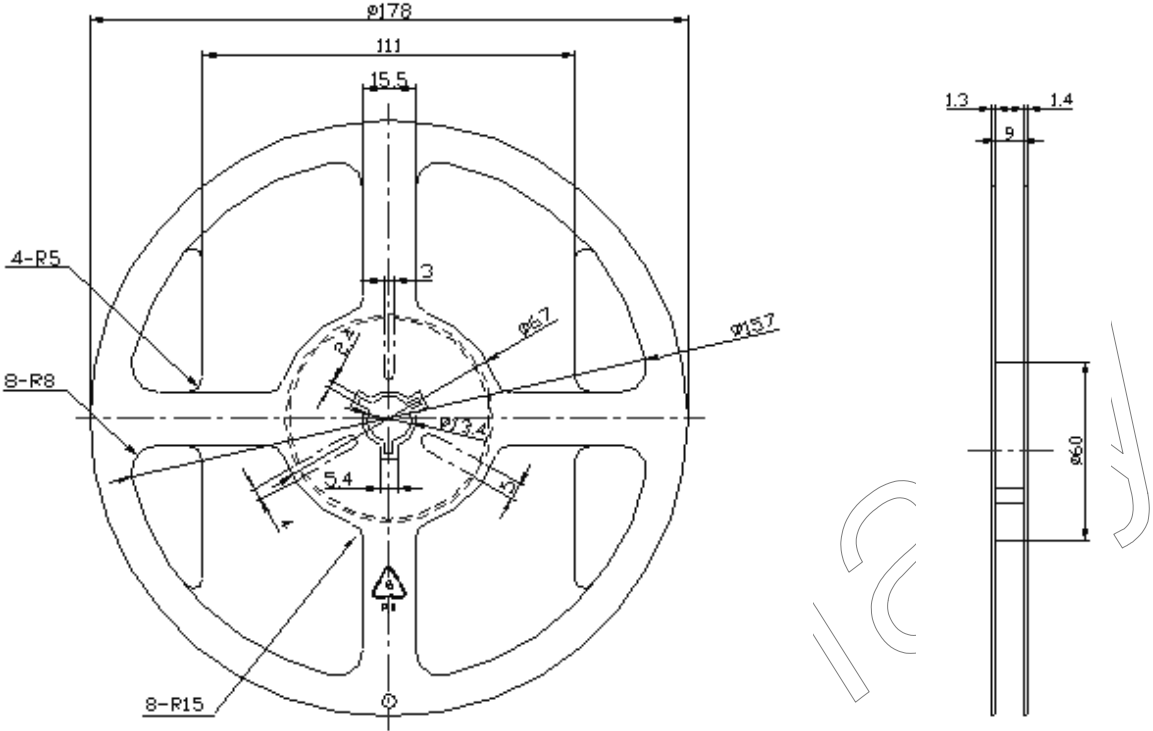

9.6 Tape and Reel

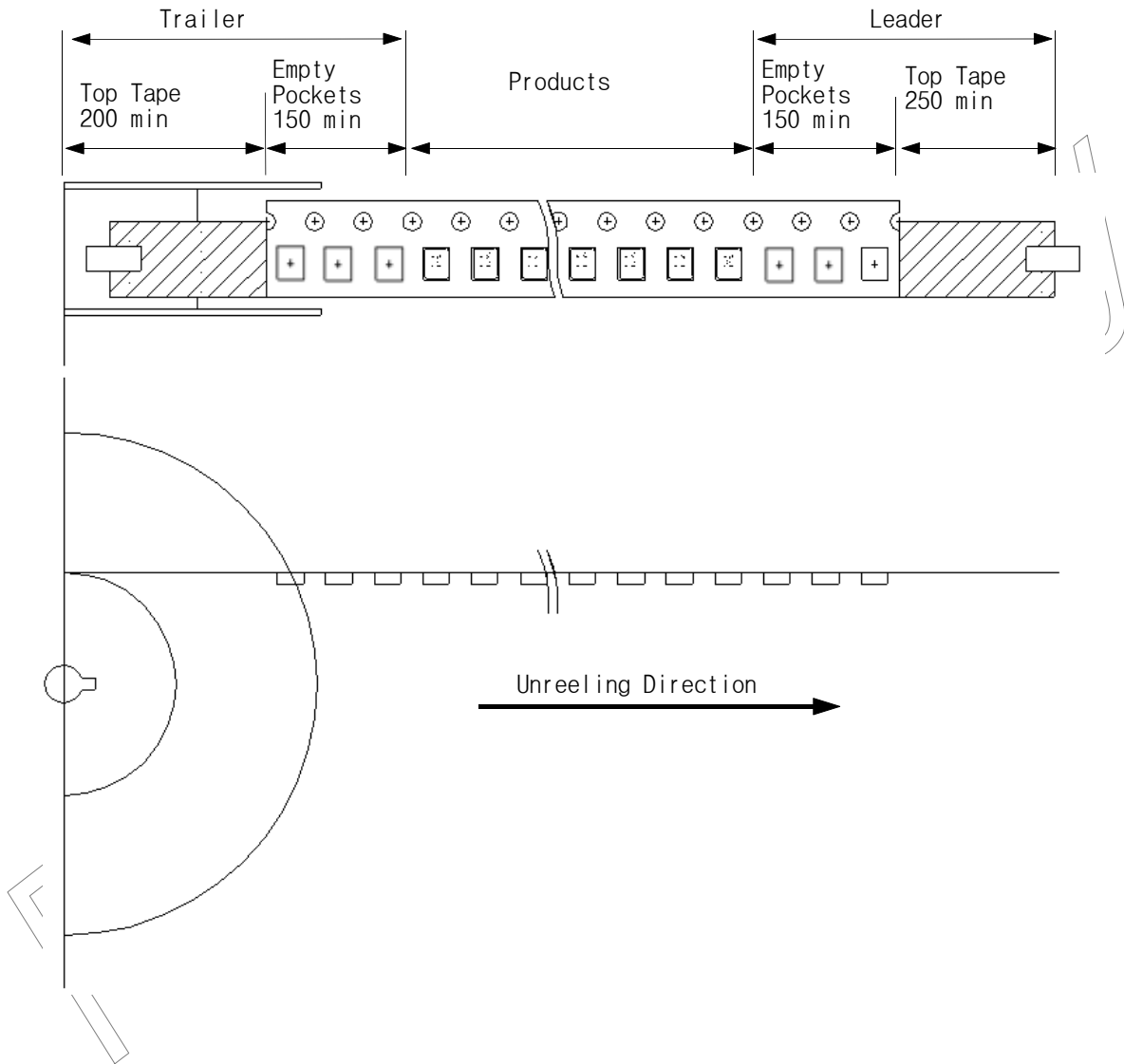

9.7 Inner, outer box Dimensions (unit : mm)

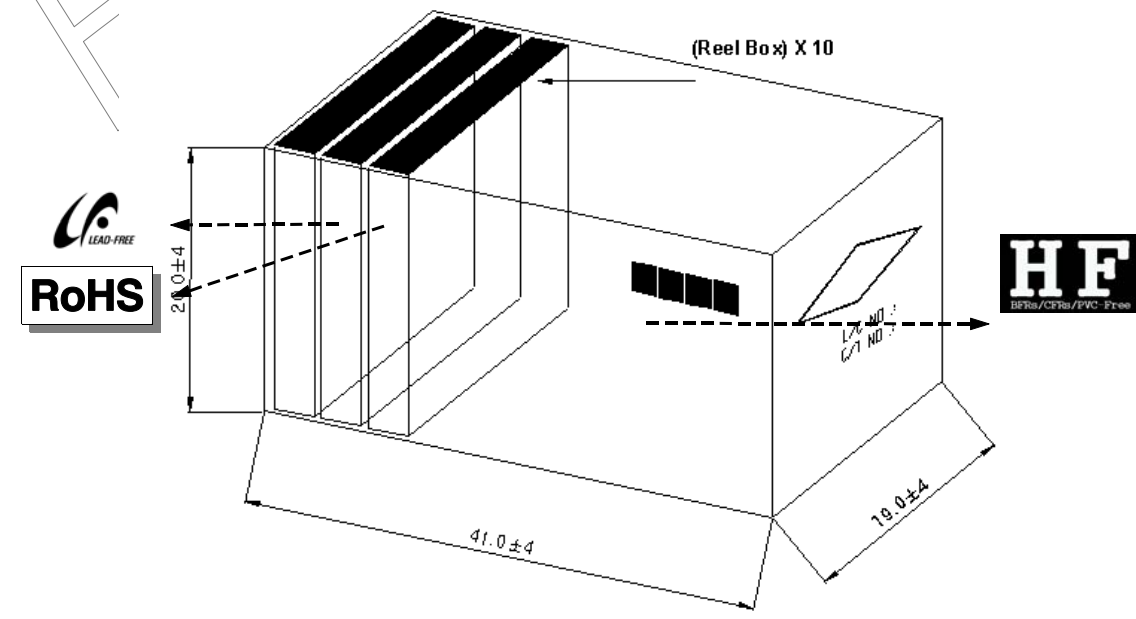
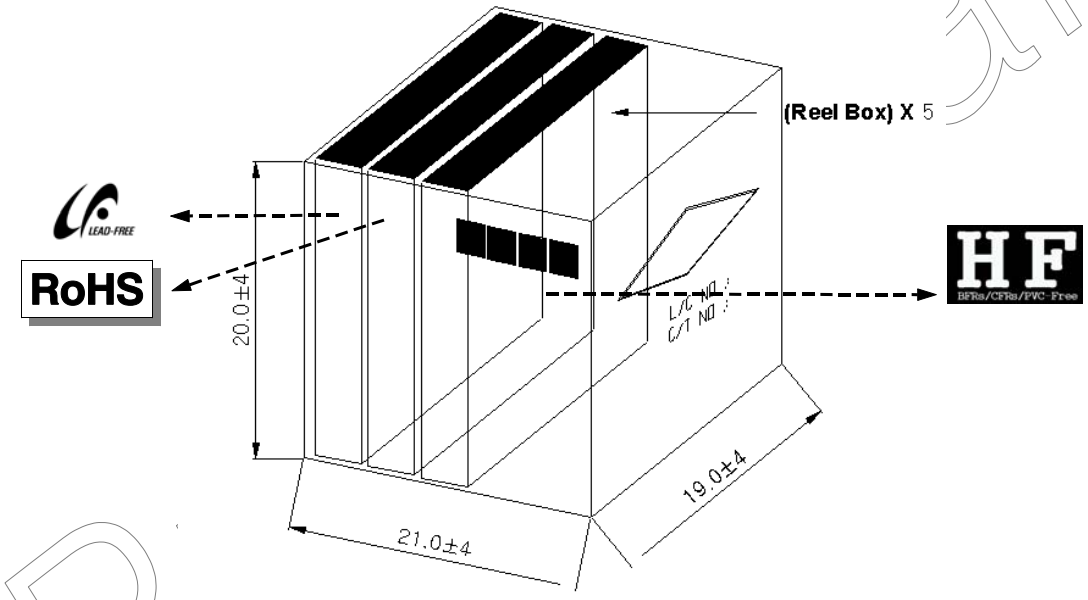
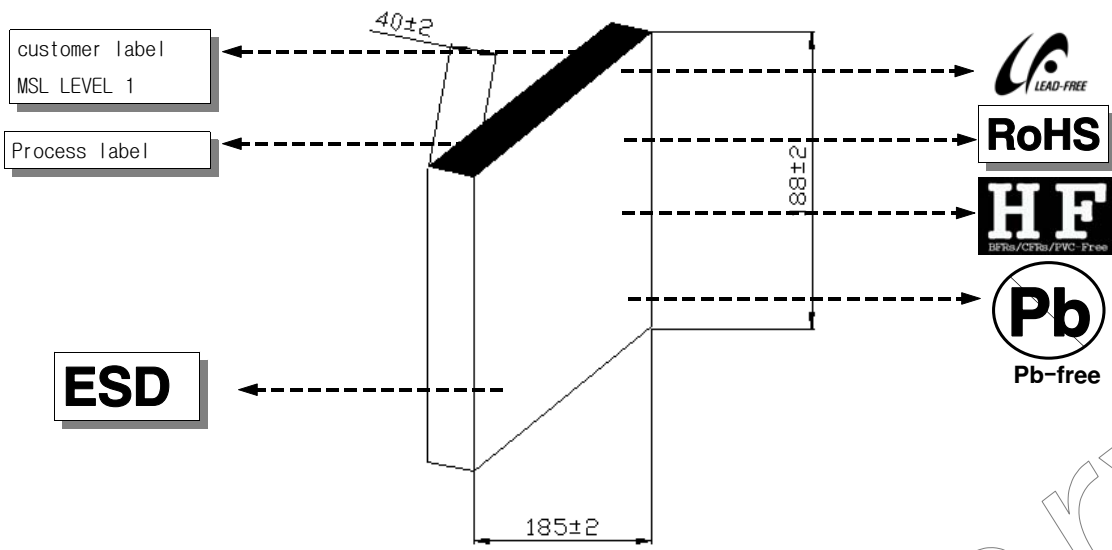

X-ON Electronics

Largest Supplier of Electrical and Electronic Components

Click to view similar products for [Crystals](#) category:

Click to view products by [Partron](#) manufacturer:

Other Similar products are found below :

[CX3225GB25000M0PPSZ1](#) [718-13.2-1](#) [MC405 32.0000K-R3:PURE SN](#) [7A-40.000MAAE-T](#) [FL2000085](#) [99-BU](#) [9B-15.360MBBK-B](#) [9C-7.680MBBK-T](#) [H10S-12.000-18-EXT-TR](#) [ABC2-6.000MHZ-D4Z-T](#) [ABLS-20.000MHZ-D2-T](#) [ABS071-32.768KHZ-6-T](#) [R38-32.768-12.5-5PPM-NPB](#) [BTD1062E05A-513](#) [21U15A-21.4MHZ](#) [RTX-781DF1-S-20.950](#) [LFXTAL066198Cutt](#) [9C-14.31818MBBK-T](#) [A-11.000MHZ-27](#) [ABL-27.000MHZ-B4Y-T](#) [ABM11-132-24.000MHZ-T3](#) [ABM3B1-25.000MHZ-D2Y-T](#) [SPT2A-.032768B](#) [SPT2A.032768G](#) [SSPT7F-9PF20-R](#) [FX325BS-38.88EEM1201](#) [LFXTAL065253Cutt](#) [LFXTAL066431Cutt](#) [XT9S20ANA14M7456](#) [XT9SNLANA16M](#) [646G-24-2](#) [7A-24.576MBBK-T](#) [7B-30.000MBBK-T](#) [7A-14.31818MBBK-T](#) [6504-202-1501](#) [6526-202-1501](#) [ABLS-12.000MHZ-B2Y-T](#) [ABLS-10.000MHZ-D3W-T](#) [7A-10.000MBBK-T](#) [SG636PCE-20.000MC](#) [3404](#) [E1SAA18-25.000M TR](#) [CM315D32768EZFT](#) [C1E-24.000-7-2020-R](#) [C1E-19.200-12-1530-X-R](#) [C1E-16.000-12-1530-X-R](#) [FL5000014](#) [EUCA18-3.1872M](#) [FX0800015](#) [425F35E027M0000](#)