

# Peak Atlas DCA

*Semiconductor Component Analyser  
Model DCA55*

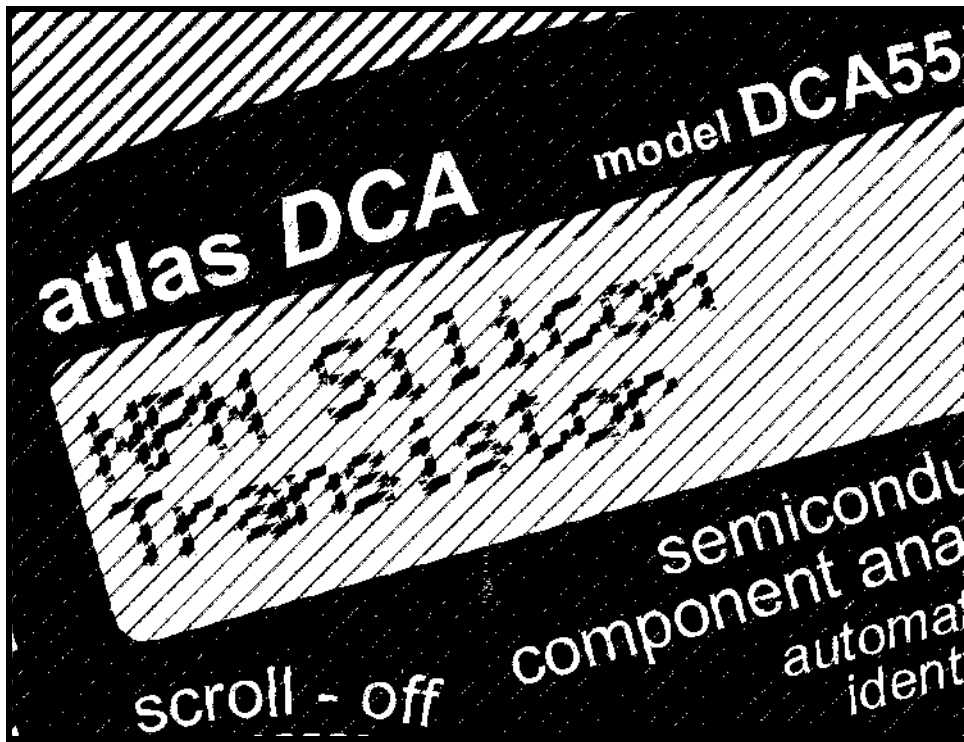

Designed and manufactured with pride in the UK

## User Guide

© Peak Electronic Design Limited 2000/2012

In the interests of development, information in this guide is subject to change without notice - E&OE



## Want to use it now?

We understand that you want to use your *Atlas DCA* right now. The unit is ready to go and you should have little need to refer to this user guide, but please make sure that you do at least take a look at the notices on page 4!

<b>Contents</b>	<b>Page</b>
Introduction.....	3
Important Considerations .....	4
Analysing semiconductors .....	5
Diodes.....	7
Diode Networks.....	8
LEDs.....	9
Bicolour LEDs.....	10
Bipolar Junction Transistors (BJTs).....	11
Digital Transistors.....	18
Enhancement Mode MOSFETs .....	19
Depletion Mode MOSFETs .....	20
Junction FETs (JFETs) .....	21
Thyristors (SCRs) and Triacs.....	22
Taking care of your <i>Atlas DCA</i> .....	23
Battery replacement .....	23
Self Tests .....	24
Appendix A - Technical Specifications.....	25
Appendix B - Warranty Information .....	26
Appendix C - Disposal information .....	27

## Introduction

The *Peak Atlas DCA* is an intelligent semiconductor analyser that offers great features together with refreshing simplicity. The *Atlas DCA* brings a world of component data to your fingertips.

### Summary Features:

- Automatic component type identification
  - Bipolar transistors
  - Darlington transistors
  - Enhancement Mode MOSFETs
  - Depletion Mode MOSFETs
  - Junction FETs
  - Low power sensitive Triacs
  - Low power sensitive Thyristors
  - Light Emitting Diodes
  - Bicolour LEDs
  - Diodes
  - Diode networks
- Automatic pinout identification, just connect any way round.
- Special feature identification such as diode protection and resistor shunts.
- Gain measurement for bipolar transistors.
- Leakage current measurement for bipolar transistors.
- Silicon and Germanium detection for bipolar transistors.
- Gate threshold measurement for Enhancement Mode MOSFETs.
- Semiconductor forward voltage measurement for diodes, LEDs and transistor Base-Emitter junctions.
- Automatic and manual power-off.

## Important Considerations

Please observe the following guidelines:

- This instrument must NEVER be connected to powered equipment/components or equipment/components with any stored energy (e.g. charged capacitors). Failure to comply with this warning may result in personal injury, damage to the equipment under test, damage to the *Atlas DCA* and invalidation of the manufacturer's warranty.
- The *Atlas DCA* is designed to analyse semiconductors that are not in-circuit, otherwise complex circuit effects will result in erroneous measurements.
- Avoid rough treatment or hard knocks.
- This unit is not waterproof.
- Only use a good quality Alkaline battery.

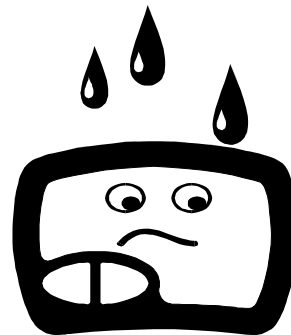
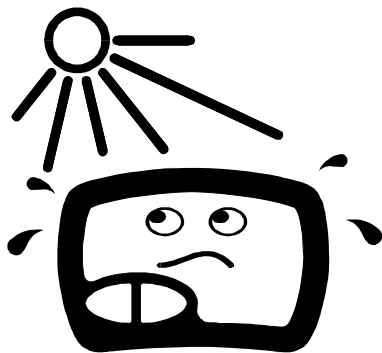

## Analysing Components

The *Atlas DCA* is designed to analyse discrete, unconnected, unpowered components. This ensures that external connections don't influence the measured parameters. The three test probes can be connected to the component any way round. If the component has only two terminals, then any pair of the three test probes can be used.

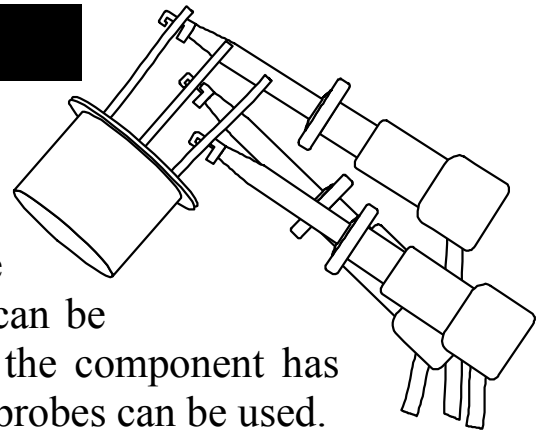

```
Atlas DCA55 Rx.x  
is analysing....
```

The *Atlas DCA* will start component analysis when the **on-test** button is pressed.

Depending on the component type, analysis may take a few seconds to complete, after which, the results of the analysis are displayed. Information is displayed a “page” at a time, each page can be displayed by briefly pressing the **scroll-off** button.



The arrow symbol on the display indicates that more pages are available to be viewed.



Although the *Atlas DCA* will switch itself off if left unattended, you can manually switch the unit off by holding down the **scroll-off** button for a couple of seconds.

If the *Atlas DCA* cannot detect any component between any of the test probes, the following message will be displayed:

```
No component
detected
```

If the component is not a supported component type, a faulty component or a component that is being tested in-circuit, the analysis may result in the following message being displayed:

```
Unknown/Faulty
component
```

Some components may be faulty due to a shorted junction between a pair of the probes. If this is the case, the following message (or similar) will be displayed:

```
Short circuit on
Green Blue
```

If all three probes are shorted (or very low resistance) then the following message will be displayed:

```
Short circuit on
Red Green Blue
```



It is possible that the *Atlas DCA* may detect one or more diode junctions or other component type within an unknown or faulty part. This is because many semiconductors comprise of PN (diode) junctions. Please refer to the section on diodes and diode networks for more information.

## Diodes

The *Atlas DCA* will analyse almost any type of diode. Any pair of the three test clips can be connected to the diode, any way round. If the unit detects a single diode, the following message will be displayed:

```
Diode or diode
junction(s)
```

```
RED GREEN BLUE
Anod Cath
```

```
Forward voltage
Vf=0.67V
```

```
Test current
If=4.62mA
```

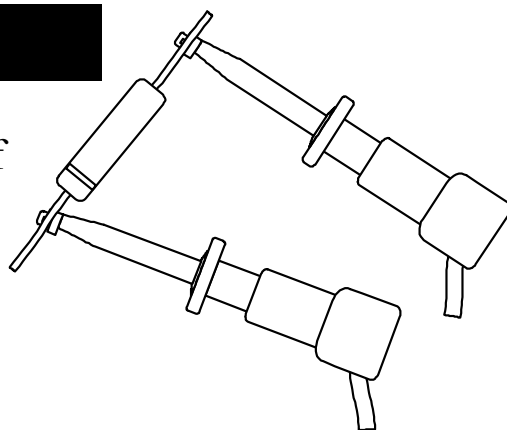

Pressing the **scroll-off** button will then display the pinout for the diode. In this example, the Anode of the diode is connected to the Red test clip and the Cathode is connected to the Green test clip, additionally, the Blue test clip is unconnected. The forward voltage drop is then displayed, this gives an indication of the diode technology. In this example, it is likely that the diode is a silicon diode. A germanium or Schottky diode may yield a forward voltage of about 0.25V. The current at which the diode was tested is also displayed.



Note that the *Atlas DCA* will detect only one diode even if two diodes are connected in series when the third test clip is not connected to the junction between the diodes. The forward voltage drop displayed however will be the voltage across the whole series combination.



The *Atlas DCA* will determine that the diode(s) under test is an LED if the measured forward voltage drop exceeds 1.50V. Please refer to the section on LED analysis for more information.

# Diode Networks

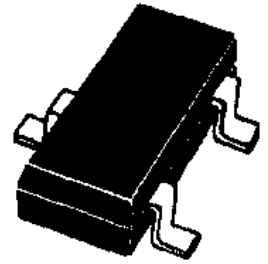

The *Atlas DCA* will intelligently identify popular types of three terminal diode networks. For three terminal devices such as SOT-23 diode networks, the three test clips must all be connected, any way round. The instrument will identify the type of diode network and then display information regarding each detected diode in sequence. The following types of diode networks are automatically recognised by the *Atlas DCA*:

Common cathode diode network



Both cathodes connected together, such as the BAV70 device.

Common anode diode network

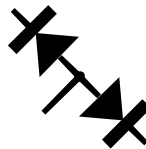

Anodes of each diode are connected together, the BAW56W is an example.

Series diode network



Here, each diode is connected in series. An example is the BAV99.

Following the component identification, the details of each diode in the network will be displayed.

Pinout for D1...

Firstly, the pinout for the diode is displayed, followed by the electrical information, forward voltage drop and the current at which the diode was tested. The value of the test current depends on the measured forward voltage drop of the diode.

RED GREEN BLUE  
Cath Anod

Forward voltage  
D1 Vf=0.64V

Following the display of all the details for the first diode, the details of the second diode will then be displayed.



## LEDs

An LED is really just another type of diode, however, the *Atlas DCA* will determine that an LED or LED network has been detected if the measured forward voltage drop is larger than 1.5V. This also enables the *Atlas DCA* to intelligently identify bicolour LEDs, both two-terminal and three-terminal varieties.

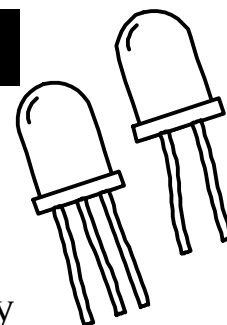

LED or diode  
junction(s)

Like the diode analysis, the pinout, the forward voltage drop and the associated test current is displayed.

RED GREEN BLUE  
Cath Anod

Here, the Cathode (-ve) LED terminal is connected to the Green test clip and the Anode (+ve) LED terminal is connected to the Blue test clip.

Forward voltage  
 $V_f=1.92V$

In this example, a simple green LED yields a forward voltage drop of 1.92V.

Test current  
 $I_f=3.28mA$

The test current is dependant on the forward voltage drop of the LED, here the test current is measured as 3.28mA.



Some blue LEDs (and their cousins, white LEDs) require high forward voltages and may not be detected by the *Atlas DCA*.

## Bicolour LEDs

Bicolour LEDs are automatically identified. If your LED has 3 leads then ensure they are all connected, in any order.

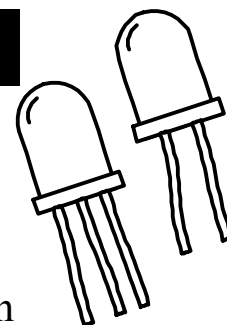

A two terminal bicolour LED consists of two LED chips which are connected in inverse parallel within the LED body. Three terminal bicolour LEDs are made with either common anodes or common cathodes.

Two terminal  
bicolour LED

Here a two terminal LED has been detected.

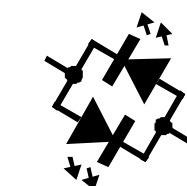

Three terminal  
bicolour LED

This message will be displayed if the unit has detected a three terminal LED.

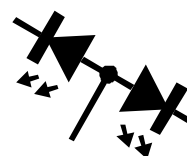

The details of each LED in the package will then be displayed in a similar way to the diode networks detailed earlier.

The pinout for the 1<sup>st</sup> LED is displayed. Remember that this is the pinout for just one of the two LEDs in the package.

Interestingly, the voltage drops for each LED relate to the different colours within the bicolour LED. It may therefore be possible to determine which lead is connected to each colour LED within the device. Red LEDs often have the lowest forward voltage drop, followed by yellow LEDs, green LEDs and finally, blue LEDs.

Pinout for D1...

RED GREEN BLUE  
Anod Cath

Forward voltage  
D1 Vf=1.98V

Test current  
D1 If=3.22mA

## Bipolar Junction Transistors (BJTs)

Bipolar Junction Transistors are simply “conventional” transistors, although variants of these do exist such as Darlington, diode protected (free-wheeling diode), resistor shunted types and combinations of these types. All of these variations are automatically identified by the *Atlas DCA*.

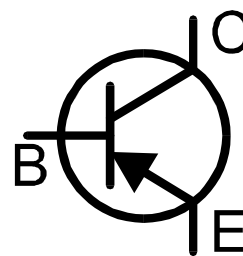

Bipolar Junction Transistors are available in two main types, NPN and PNP. In this example, the unit has detected a Silicon PNP transistor.

PNP Silicon  
Transistor

PNP Germanium  
Transistor

The unit will determine that the transistor is Germanium only if the base-emitter voltage drop is less than 0.55V.

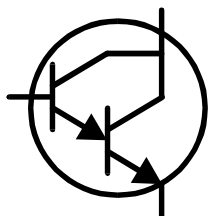

If the device is a Darlington transistor (two BJTs connected together), the unit will display a similar message to this:

NPN Darlington  
Transistor



Note that the *Atlas DCA* will determine that the transistor under test is a Darlington type if the base-emitter voltage drop is greater than 1.00V for devices with a base-emitter shunt resistance of greater than 60k $\Omega$  or if the base-emitter voltage drop is greater than 0.80V for devices with a base-emitter shunt resistance of less than 60k $\Omega$ . The measured base-emitter voltage drop is displayed as detailed later in this section.

Pressing the **scroll-off** button will result in the transistor's pinout being displayed.

Here, the instrument has identified that the Base is connected to the Red test clip, the Collector is connected to the Green test clip and the Emitter is connected to the Blue test clip.

```
RED GREEN BLUE
Base Coll Emit
```

### Transistor Special Features

Many modern transistors contain additional special features. If the *Atlas DCA* has detected any special features, then the details of these features are displayed next after pressing the **scroll-off** button. If there are no special features detected then the next screen will be the transistor's current gain.

Some transistors, particularly CRT deflection transistors and many large Darlington's have a protection diode inside their package connected between the collector and emitter.

```
Diode Protection
between C-E
```

The Philips BU505DF is a typical example of a diode protected bipolar transistor. Remember that protection diodes are always internally connected between the collector and the emitter so that they are normally reverse biased.

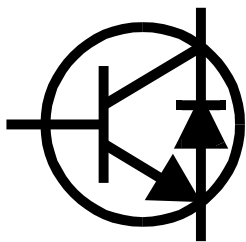

For NPN transistors, the anode of the diode is connected to the emitter of the transistor. For PNP transistors, the anode of the diode is connected to the collector of the transistor.

Additionally, many Darlingtontons and a few non-Darlington transistors also have a resistor shunt network between the base and emitter of the device.

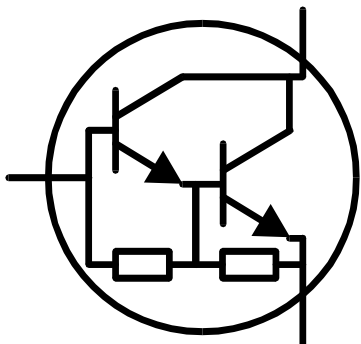

The *Atlas DCA* can detect the resistor shunt if it has a resistance of typically less than 60k $\Omega$ .

The popular Motorola TIP110 NPN Darlington transistor contains internal resistors between the base and emitter.

When the unit detects the presence of a resistive shunt between the base and emitter, the display will show:

Resistor shunt  
between B-E

Additionally, the *Atlas DCA* will warn you that the accuracy of gain measurement ( $H_{FE}$ ) has been affected by the shunt resistor.

$H_{FE}$  not accurate  
due to B-E res



It is important to note that if a transistor does contain a base-emitter shunt resistor network, any measurements of current gain ( $H_{FE}$ ) will be very low at the test currents used by the *Atlas DCA*. This is due to the resistors providing an additional path for the base current. The readings for gain however can still be used for comparing transistors of a similar type for the purposes of matching or gain band selecting. The *Atlas DCA* will warn you if such a condition arises as illustrated above.

## Faulty or Very Low Gain Transistors

Faulty transistors that exhibit very low gain may cause the *Atlas DCA* to only identify one or more diode junctions within the device. This is because NPN transistors consist of a structure of junctions that behave like a common anode diode network. PNP transistors can appear to be common cathode diode networks. The common junction represents the base terminal. This is normal

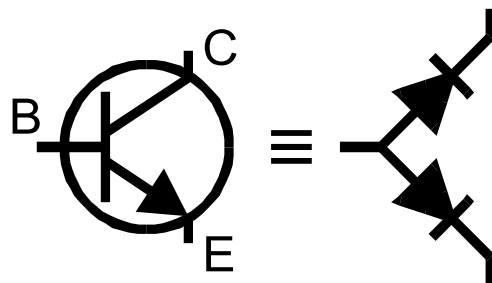

for situations where the current gain is so low that it is immeasurable at the test currents used by the *Atlas DCA*.

Common anode  
diode network



Please note that the equivalent diode pattern may not be correctly identified by the *Atlas DCA* if your transistor is a darlington type or has additional diode(s) in its package (such as a collector-emitter protection diode). This is due to multiple pn junctions that cannot be uniquely analysed.

In some circumstances, the unit may not be able to deduce anything sensible from the device at all, in which case you will see either of these messages:

Unknown/Faulty  
component

No component  
detected

## Current Gain ( $H_{FE}$ )

The DC current gain ( $H_{FE}$ ) is displayed after any special transistor features have been displayed.

DC current gain is simply the ratio of the collector current (less leakage) to the base current for a particular operating condition. The *Atlas DCA* measures  $H_{FE}$  at a collector current of 2.50mA and a collector-emitter voltage of between 2V and 3V.

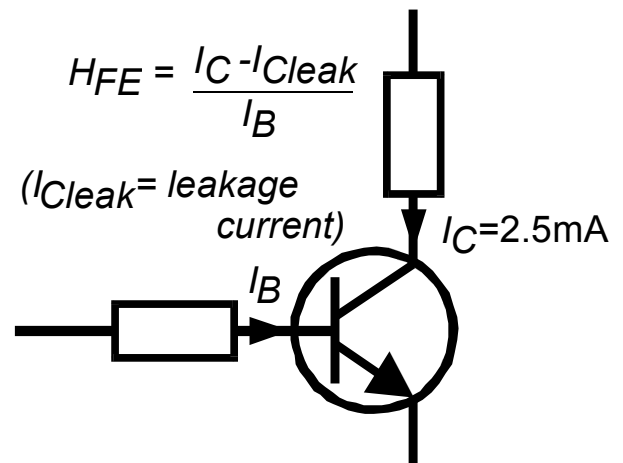

Current gain  
 $H_{FE}=126$

Test current  
 $I_C=2.50\text{mA}$

The gain of all transistors can vary considerably with collector current, collector voltage and also temperature. The displayed value for gain therefore may not represent the gain experienced at other collector currents and voltages. This is particularly true for large devices.

Darlington transistors can have very high gain values and more variation of gain will be evident as a result of this.

Additionally, it is quite normal for transistors of the same type to have a wide range of gain values. For this reason, transistor circuits are often designed so that their operation has little dependence on the absolute value of current gain.

The displayed value of gain is very useful however for comparing transistors of a similar type for the purposes of gain matching or fault finding.

## Base-Emitter Voltage Drop

The DC characteristics of the base-emitter junction are displayed, both the base-emitter forward voltage drop and the base current used for the measurement.

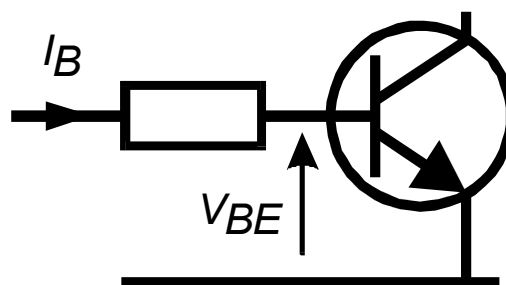

B-E Voltage  
 $V_{be}=0.77V$

Test current  
 $I_b=4.52mA$

The forward base-emitter voltage drop can aid in the identification of silicon or germanium devices. Germanium devices can have base-emitter voltages as low as 0.2V, Silicon types exhibit readings of about 0.7V and Darlington transistors

can exhibit readings of about 1.2V because of the multiple base-emitter junctions being measured.



Note that the *Atlas DCA* does not perform the base-emitter tests at the same base current as that used for the current gain measurement.



## Collector Leakage Current

The collector current that takes place when no base current is flowing is referred to as *Leakage Current*.

Most modern transistor exhibit extremely low values of leakage current, often less than  $1\mu\text{A}$ , even for very high collector-emitter voltages.

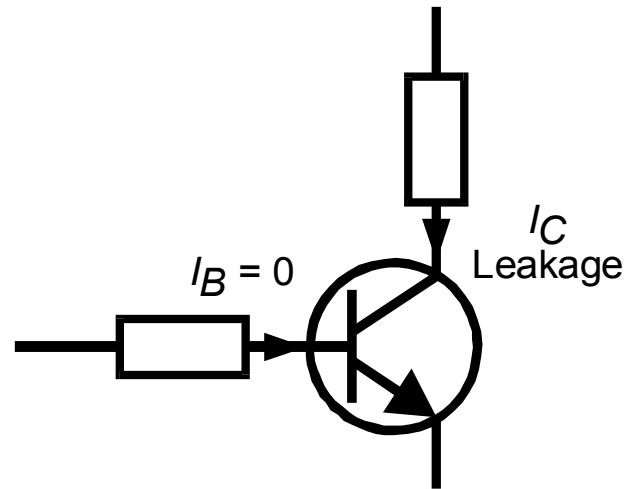

Leakage current  
 $I_c = 0.17\text{mA}$

Older Germanium types however can suffer from significant collector leakage current, particular at high temperatures (leakage current can be very temperature dependant).

If your transistor is a Silicon type, you should expect to see a leakage current of close to  $0.00\text{mA}$  unless the transistor is faulty.

# Digital Transistors

Digital transistors aren't really digital, they can act in both a linear or fully on/off mode. They're called "digital transistors" because they can be driven directly to digital outputs without the need for current limiting resistors.

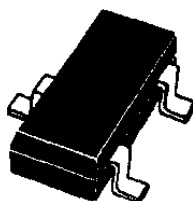
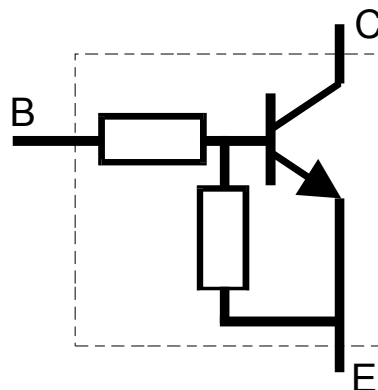

These parts are most often found in surface mount packages but are becoming more common, particularly in mass produced electronic products.

The presence of the base resistor (and the base-emitter shunt resistor) means that it isn't possible for the Atlas DCA to measure the gain of the device, so only the device polarity (NPN/PNP) and pinout is shown.

NPN Digital  
Transistor

RED GREEN BLUE  
Emit Base Coll

# Enhancement Mode MOSFETs

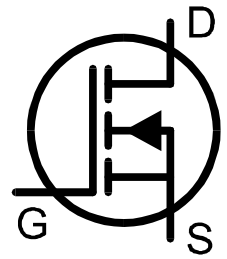

MOSFET stands for *Metal Oxide Semiconductor Field Effect Transistor*. Like bipolar transistors, MOSFETs are available in two main types, N-Channel and P-Channel. Most modern MOSFETs are of the Enhancement Mode type, meaning that

Enhancement mode  
N-Ch MOSFET

the bias of the gate-source voltage is always positive (For N-Channel types). The other (rarer) type of MOSFET is the Depletion Mode type which is described in a later section.

MOSFETs of all types are sometimes known as IGFETs, meaning *Insulated Gate Field Effect Transistor*. This term describes a key feature of these devices, an insulated gate region that results in negligible gate current for both positive and negative gate-source voltages (up to the maximum allowed values of course, typically  $\pm 20V$ ).

The first screen to be displayed gives information on the type of MOSFET detected. Pressing **scroll-off** will then result in the pinout of the MOSFET being displayed. The gate, source and drain are each identified.

RED GREEN BLUE  
Gate Drn Srce

An important feature of a MOSFET is the gate-source threshold voltage, the gate-source voltage at which conduction between the source and drain starts. The gate threshold is displayed following the pinout information.

Gate Threshold  
 $V_{gs}=3.47V$

The *Atlas DCA* detects that drain-source conduction has started when it reaches 2.50mA.

Test current  
 $I_d=2.50mA$

# Depletion Mode MOSFETs

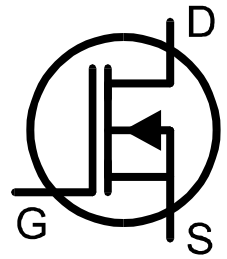

The fairly rare Depletion Mode MOSFET is very similar to the conventional Junction FET (JFET) except that the gate terminal is insulated from the other two terminals. The input resistance of these devices can typically be greater than 1000MΩ for negative and positive gate-source voltages.

Depletion mode  
N-Ch MOSFET

Depletion Mode devices are characterised by the gate-source voltage required to control the drain-source current.

Modern Depletion Mode devices are generally only available in N-Channel varieties and will conduct current between its drain and source terminals even with a zero voltage applied across the gate and the source. The device can only be turned completely off by taking its gate significantly more negative than its source terminal, say -10V. It is this characteristic that makes them so similar to conventional JFETs.

Pressing **scroll-off** will cause the pinout screen to be displayed.

RED GREEN BLUE  
Drn Gate Srce

## Junction FETs (JFETs)

Junction FETs are conventional Field Effect Transistors.

The voltage applied across the gate-source terminals controls current between the drain and source terminals. N-Channel JFETs require a negative voltage on their gate with respect to their source, the more negative the voltage, the less current can flow between the drain and source.

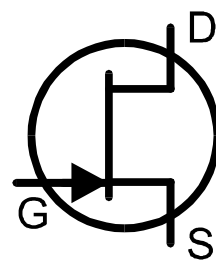

P-Channel  
Junction FET

Unlike Depletion Mode MOSFETs, JFETs have no insulation layer on the gate. This means that although the input resistance between the gate and source is

normally very high (greater than  $100\text{M}\Omega$ ), the gate current can rise if the semiconductor junction between the gate and source or between the gate and drain become forward biased. This can happen if the gate voltage becomes about 0.6V higher than either the drain or source terminals for N-Channel devices or 0.6V lower than the drain or source for P-Channel devices.

Drain and Source  
not identified

The internal structure of JFETs is essentially symmetrical about the gate terminal, this means that the drain and source terminals are indistinguishable by the *Atlas DCA*. The JFET type and the gate terminal are identified however.

RED GREEN BLUE  
Gate

## Thyristors (SCRs) and Triacs

Sensitive low power thyristors (Silicon Controlled Rectifiers - SCRs) and triacs that require gate currents and holding currents of less than 5mA can be identified and analysed with the *Atlas DCA*.

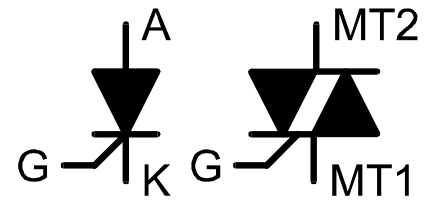

Sensitive or low  
Power thyristor

Thyristor terminals are the anode, cathode and the gate. The pinout of the thyristor under test will be displayed on the next press of the **scroll-off** button.

RED GREEN BLUE  
Gate Anod Cath

Triac terminals are the MT1, MT2 (MT standing for main terminal) and gate. MT1 is the terminal with which gate current is referenced.

Sensitive or low  
Power triac

RED GREEN BLUE  
MT1 MT2 Gate



1. The unit determines that the device under test is a triac by checking the gate trigger quadrants that the device will reliably operate in. Thyristors operate in only one quadrant (positive gate current, positive anode current). Triacs can typically operate in three or four quadrants, hence their use in AC control applications.
  
2. The test currents used by the *Atlas DCA* are kept low (<5mA) to eliminate the possibility of damage to a vast range of component types. Some thyristors and triacs will not operate at low currents and these types cannot be analysed with this instrument. Note also that if only one trigger quadrant of a triac is detected then the unit will conclude that it has found a thyristor. Please see the technical specifications for more details.

## Care of your *Atlas DCA*

The *Peak Atlas DCA* should provide many years of service if used in accordance with this user guide. Care should be taken not to expose your unit to excessive heat, shock or moisture. Additionally, the battery should be replaced at least every 12 months to reduce the risk of leak damage.

If a low battery warning message appears, immediate replacement of the battery is recommended as measured parameters may be affected. The unit may however continue to operate.

\* Low Battery \*

The battery can be replaced by carefully opening the *Atlas DCA* by removing the three screws from the rear of the unit. Take care not to damage the electronics.

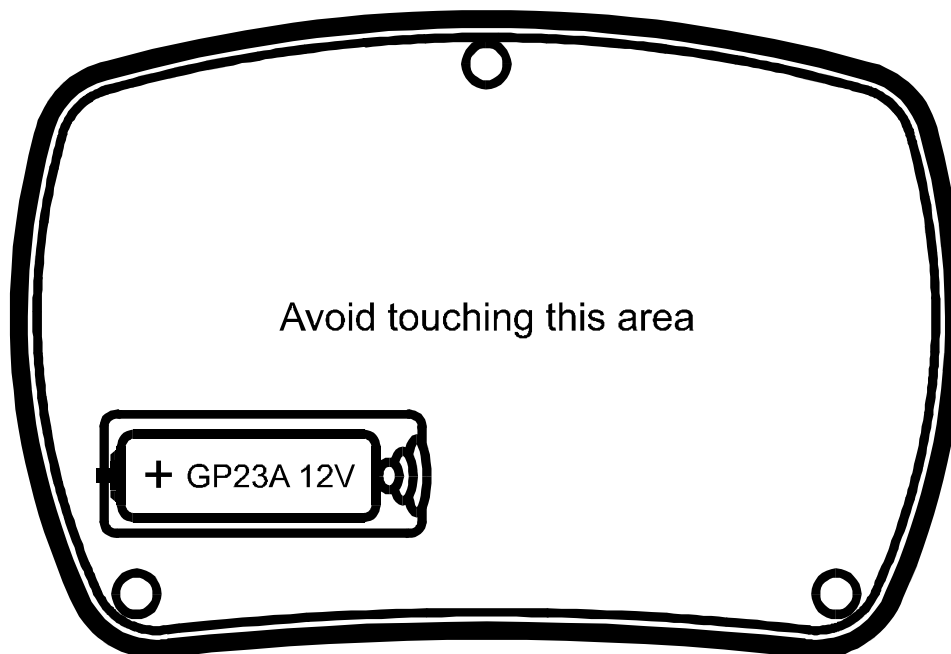

The battery should only be replaced with a high quality battery identical to, or equivalent to an Alkaline GP23A or MN21 12V (10mm diameter x 28mm length). Replacement batteries are available directly from Peak Electronic Design Limited and many good electronic/automotive outlets.

## Self Test Procedure

Each time the *Atlas DCA* is powered up, a self test procedure is performed. In addition to a battery voltage test, the unit measures the performance of many internal functions such as the voltage and current sources, amplifiers, analogue to digital converters and test lead multiplexers. If any of these function measurements fall outside tight performance limits, a message will be displayed and the instrument will switch off automatically.

If the problem was caused by a temporary condition on the test clips, such as applying power to the test clips, then simply re-starting the *Atlas DCA* may clear the problem.



```
Self test failed  
CODE: 5
```

If a persistent problem does arise, it is likely that damage has been caused by an external event such as excessive power being applied to the test clips or a large static discharge taking place. If the problem persists, please contact us for further advice, quoting the displayed fault code.



If there is a low battery condition, the automatic self test procedure will not be performed. For this reason, it is highly recommended that the battery is replaced as soon as possible following a “Low Battery” warning.



## Appendix A - Technical Specifications

All values are at 25°C unless otherwise specified.

Parameter	Min	Typ	Max	Note
Peak test current into S/C	-5.5mA		5.5mA	1
Peak test voltage across O/C	-5.1V		5.1V	1
Transistor gain range ( $H_{FE}$ )	4		20000	2
Transistor gain accuracy	$\pm 3\% \pm 5 H_{FE}$			2,8
Transistor $V_{CEO}$ test voltage	2.0V		3.0V	2
Transistor $V_{BE}$ accuracy	-2%-20mV		+2%+20mV	8
$V_{BE}$ for Darlington	0.95V	1.00V	1.80V	3
$V_{BE}$ for Darlington (shunted)	0.75V	0.80V	1.80V	4
Acceptable transistor $V_{BE}$			1.80V	
Base-emitter shunt threshold	50k $\Omega$	60k $\Omega$	70k $\Omega$	
BJT collector test current	2.45mA	2.50mA	2.55mA	
BJT acceptable leakage			0.7mA	6
MOSFET gate threshold range	0.1V		5.0V	5
MOSFET threshold accuracy	-2%-20mV		+2%+20mV	5
MOSFET drain test current	2.45mA	2.50mA	2.55mA	
MOSFET gate resistance	8k $\Omega$			
Depletion drain test current	0.5mA		5.5mA	
JFET drain-source test current	0.5mA		5.5mA	
SCR/Triac gate test current		4.5mA		7
SCR/Triac load test current		5.0mA		
Diode test current			5.0mA	
Diode voltage accuracy	-2%-20mV		+2%+20mV	
$V_F$ for LED identification	1.50V		4.00V	
Short circuit threshold		10 $\Omega$		
Battery type	MN21 / L1028 / GP23A 12V Alkaline			
Battery voltage range	7.50V	12V		
Battery warning threshold		8.25V		
Dimensions (body)	103 x 70 x 20 mm			

- Between any pair of test clips.
- Collector current of 2.50mA. Gain accuracy valid for gains less than 2000.
- Resistance across reverse biased base-emitter > 60k $\Omega$ .
- Resistance across reverse biased base-emitter < 60k $\Omega$ .
- Drain-source current of 2.50mA.
- Collector-emitter voltage of 5.0V.
- Thyristor quadrant I, Triac quadrants I and III.
- BJT with no shunt resistors.

Please note, specifications subject to change.

## Appendix B – Warranty Information

### Peak Satisfaction Guarantee

If for any reason you are not completely satisfied with the *Peak Atlas DCA* within 14 days of purchase you may return the unit to your distributor. You will receive a refund covering the full purchase price if the unit is returned in perfect condition.

### Peak Warranty

The warranty is valid for 24 months from date of purchase. This warranty covers the cost of repair or replacement due to defects in materials and/or manufacturing faults.

The warranty does not cover malfunction or defects caused by:

- a) Operation outside the scope of the user guide.
- b) Unauthorised access or modification of the unit (except for battery replacement).
- c) Accidental physical damage or abuse.
- d) Normal wear and tear.

The customer's statutory rights are not affected by any of the above.

All claims must be accompanied by a proof of purchase.

## Appendix C – Disposal Information



### **WEEE (Waste of Electrical and Electronic Equipment), Recycling of Electrical and Electronic Products**

#### **United Kingdom**

In 2006 the European Union introduced regulations (WEEE) for the collection and recycling of all waste electrical and electronic equipment. It is no longer permissible to simply throw away electrical and electronic equipment. Instead, these products must enter the recycling process.

Each individual EU member state has implemented the WEEE regulations into national law in slightly different ways. Please follow your national law when you want to dispose of any electrical or electronic products.

**More details can be obtained from your national WEEE recycling agency.**

If in doubt, you may send your Peak Product to us for safe and environmentally responsible disposal.

At Peak Electronic Design Ltd we are committed to continual product development and improvement.  
The specifications of our products are therefore subject to change without notice.

© 2000-2012 Peak Electronic Design Limited - E&OE  
Designed and manufactured in the UK  
www.peakelec.co.uk Tel. +44 (0) 1298 70012 Fax. +44 (0) 1298 70046

# Peak Atlas LCR

*Passive Component Analyser*  
*Model LCR40*

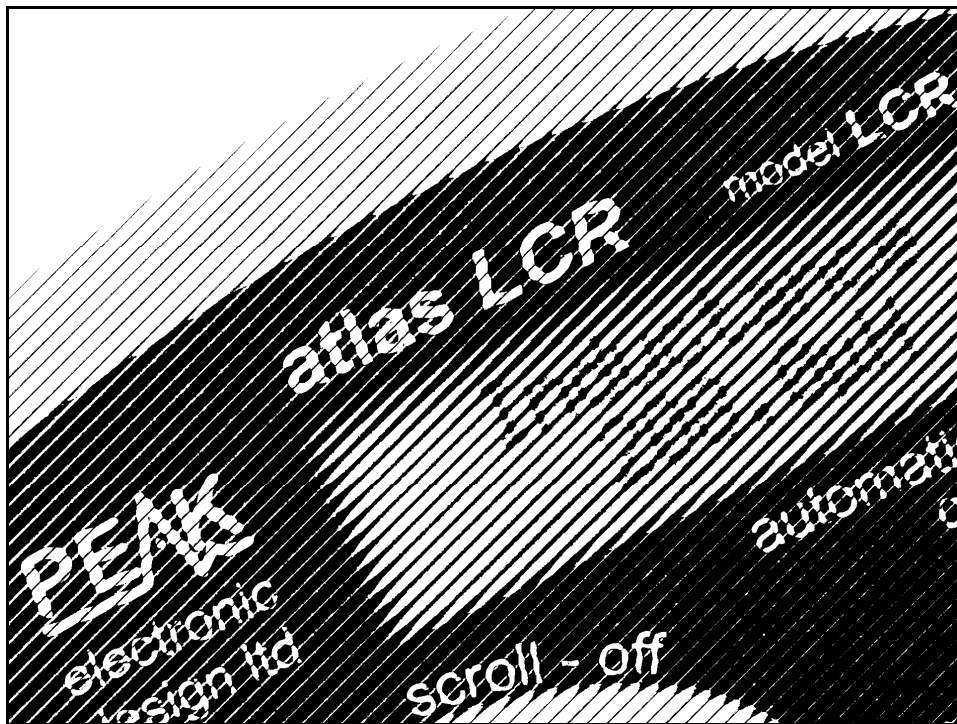

Designed and manufactured with pride in the UK

## User Guide

© Peak Electronic Design Limited 2002/2012

In the interests of development, information in this guide is subject to change without notice - E&OE



## **Want to use it now?**

We understand that you want to use your Atlas LCR right now. The unit is ready to go and you should have little need to refer to this user guide, but please make sure that you read through pages 4-6!

<b>Contents</b>	<b>Page</b>
Introduction .....	3
<b>Important Notices</b> .....	<b>4</b>
Using your Atlas LCR .....	5
Normal use	
Probe compensation	
Testing Inductors .....	7
Testing Capacitors .....	8
Testing Resistors .....	11
Low Resistance and Inductance	
Taking care of your Atlas LCR .....	12
Battery Replacement	
Self Tests	
Appendix A – Accessories .....	14
Appendix B – Component Identification.....	15
Appendix C – Technical Specifications.....	17
Appendix D – Troubleshooting .....	18
Appendix E – Warranty Information .....	19
Appendix F – Disposal Information .....	20

## Introduction

---

The Atlas LCR is an advanced instrument that greatly simplifies the testing of passive components.

Traditional LCR bridges are inherently complex and very time consuming to use.

The Atlas LCR does everything automatically, it tells you the component type in addition to component value data.

What's more, the Atlas LCR automatically selects the best signal level and frequency for the particular component under test.

The software is smart; all internal calculations are performed with floating point maths. This means that precision isn't lost in the complex internal calculations and all results are displayed in properly formatted and easy-to-read engineering units, eg. 23.6pF.

### Summary Features:

- Automatic component identification.
- Automatic test frequency selection (DC, 1kHz, 15kHz and 200kHz).
- Delayed or instant analysis (for hands free operation).
- Auto power-off.
- Probe and test lead compensation.
- Interchangeable probe sets.
- Automatic ranging and scaling.
- 1% basic accuracy for resistors.
- 1.5% basic accuracy for inductors and capacitors.

## ***Important Notices***

---

### **WARNING:**

**This instrument must NEVER be connected to powered equipment/components or equipment/components with any stored energy (e.g. charged capacitors).**

**Failure to comply with this warning may result in personal injury, damage to the equipment under test, damage to the Atlas LCR and invalidation of the manufacturer's warranty. Non-destructive overload situations are logged in the non-volatile memory within the Atlas LCR.**

***“Analysis of discrete, unconnected components is recommended.”***

 The Atlas LCR is designed to provide accurate and reliable information for the majority of supported component types (inductors, capacitors and resistors) as described in the technical specifications. Testing of other component types or component networks may give erroneous and misleading results.

## Using your Atlas LCR

---

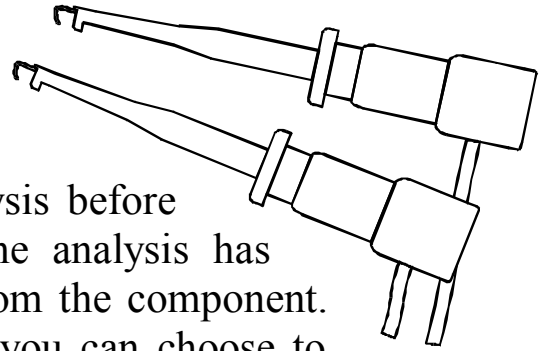

### Normal Use

The Atlas LCR performs its component analysis before the results are displayed. Therefore, once the analysis has completed, the probes can be disconnected from the component. Analysis itself only takes a few seconds and you can choose to start the analysis after a 5 second delay or immediately.

**Delayed Analysis:** If you press the **on-test** button the unit will power-up (if it's not already on!) and then delay for 5 seconds before analysis of your component starts.

Analysis starts  
in 5 seconds...

This can be particularly useful if you need time to use both hands to apply the test probes to the component while the analysis takes place.

**Instant Analysis:** You can skip the 5 second delay by pressing the **on-test** button again. The analysis will then start immediately.

Analysing...

**Scrolling through the results:** Results are displayed a screen at a time, simply press the **scroll-off** button to see each screen when you're ready.

If you reach the last screen of results, pressing **scroll-off** will take you to the first results screen again. Remember, you can take your time; and you don't need to keep the component connected.

**Starting again:** The component analysis can be started again at any time by pressing **on-test**.

**Switching off:** The unit will automatically switch off after about 20 seconds following the last keypress. If you wish, you may manually switch off by holding down the **scroll-off** button for about 1 second.



## Probe Compensation

If you change the probes on your Atlas LCR, it is good practice to run through the short compensation procedure. This ensures that the probes' own inductance, capacitance and resistance is automatically taken into account for subsequent measurements.

Before you start the compensation procedure, attach a small length of tinned copper wire between the two test probes. Now let the leads rest on a non-conductive surface, try not to touch them during the compensation procedure.

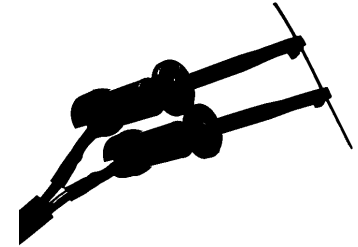

Now press and hold **on-test** until the following is displayed:

Probe  
Compensation

After a short delay, the unit will prompt you to short the probes together. As you have already shorted the probes with the piece of wire, the Atlas LCR will then ask you to open the probes.

Please short  
the probes

Now simultaneously unclip the both probes from the small length of wire and let the leads rest without touching them.

Now open  
the probes

If this procedure has been successful, the unit will display “OK” and then switch off.

At this point the parasitic and stray characteristics associated with the test leads (and indeed the Atlas LCR itself) will be stored in non-volatile memory. All further tests will have these values subtracted from the measured values, therefore displaying the characteristics of the component alone.

 Please note that probe compensation is particularly important when analysing low value inductors, capacitors and resistors.

## Testing Inductors



The Atlas LCR is designed to analyse most inductors, coils and chokes.

**Inductor test frequency:** The test frequency that the Atlas LCR uses will be automatically selected from 1kHz, 15kHz or 200kHz. The following table shows the test frequencies used for various inductance ranges:

Inductance Range	Test Frequency Used
Between 0 $\mu$ H and 0.3mH	200kHz
Between 0.3mH and 4mH	15kHz
Between 4mH and 10H	1kHz

The inductance range for each test frequency shown in the table above is **approximate**. Effects such as DC resistance, hysteresis and Q factor can influence the frequency that the Atlas LCR selects for your particular inductor.

**Inductance range:** Values ranging from about 1 $\mu$ H to 10H can be measured, with a minimum resolution of 0.4 $\mu$ H. The DC resistance of the inductor is measured from 0.5 $\Omega$  to 1k $\Omega$  with a minimum resolution of 0.3 $\Omega$ .

**Inductor results:** Following analysis, the inductance is displayed.

Press **scroll-off** to display the frequency at which the inductance was measured.

Pressing the **scroll-off** button again will display the inductor's DC resistance.

Inductance  
1.507mH

Test frequency  
15kHz

DC Resistance  
67.2 ohms

 Inductance measured for some components can be dependant on the test frequency used. The effect of frequency on inductance varies depending on the type of windings and core utilised. Even air cored inductors can show significant changes of measured inductance at different frequencies.

## Testing Capacitors

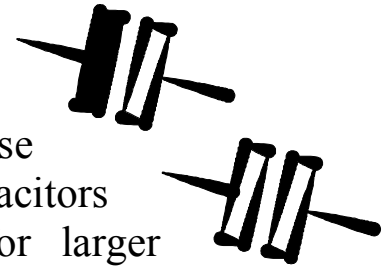

The Atlas LCR uses two different methods to analyse capacitors, AC impedance analysis for low value capacitors (less than about  $1\mu\text{F}$ ) and DC charge analysis for larger capacitors (about  $1\mu\text{F}$  to  $10,000\mu\text{F}$ ).

 Capacitors (particularly electrolytics) can store enough charge that may cause damage to the LCR.

An electrolytic capacitor can even develop its own stored charge that may be sufficient to cause damage to the Atlas LCR even after it has been temporarily discharged. This is a characteristic known as “Soakage”.

It is vitally important that you ensure the capacitor is fully discharged (ideally for several seconds) to minimise the possibility of damage to the unit.

If you are unsure, measure the voltage across the capacitor using a suitable volt meter before applying the capacitor to the Atlas LCR.

The unit will automatically identify the type of capacitor being tested and apply the most appropriate test method.

The capacitance will always be displayed in the most suitable units. To convert between the various units refer to the following table:

pF (pico-Farads)	nF (nano-Farads)	$\mu\text{F}$ (micro-Farads)	mF (milli-Farads)
1	0.001	0.000001	0.000000001
1000	1	0.001	0.000001
1000,000	1000	1	0.001
1000,000,000	1000,000	1000	1

## Low Value Capacitors

There is a vast range of low value capacitors available. Types include ceramic, polyester, polystyrene and mylar dielectric capacitors. Generally, low value capacitors tend to be unpolarised. Minimum capacitance resolution is about 0.2pF.

**Capacitor test frequency:** The Atlas LCR uses a high purity sine wave signal of 1kHz, 15kHz or 200kHz to analyse these types of capacitors. The frequency is automatically selected to give the best possible measurement resolution.

The following table shows the test frequencies used for various capacitance ranges:

Capacitance Range	Test Frequency Used
Between 0pF and 1nF	200kHz
Between 1nF and 15nF	15kHz
Between 15nF and 1 $\mu$ F	1kHz
Above 1 $\mu$ F	DC

The capacitance ranges for each test frequency shown in the table above is approximate. Effects such as leakage, dielectric dissipation and ESR can influence the frequency that the Atlas LCR selects for your particular capacitor.

**Capacitor results:** Following analysis of the capacitor, the capacitance value is displayed first. Press the **scroll-off** button to display the frequency at which the capacitance was measured.

<p>Capacitance 48.3pF</p>
-------------------------------

<p>Test frequency 200kHz</p>
----------------------------------

## Large Capacitors

Capacitors larger than about  $1\mu\text{F}$  are treated differently, instead of being tested with an AC signal, they are tested with a DC signal. This is confirmed in the “Test frequency” screen.

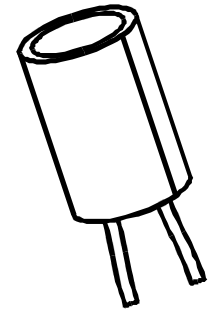

Please be patient when testing large value capacitors, it may take several seconds depending on the capacitance.

Capacitance  
106.5 $\mu\text{F}$

Test frequency  
DC

For capacitance values of greater than  $1000\mu\text{F}$ , the Atlas LCR will use the units of mF (milli-Farads). Don't confuse milli-Farads with micro-Farads,  $1\text{mF}=1000\mu\text{F}$ .

 Capacitors (particularly electrolytics) can store enough charge that may cause damage to the LCR.

An electrolytic capacitor can even develop it's own stored charge that may be sufficient to cause damage to the Atlas LCR even after it has been temporarily discharged. This is a characteristic known as “Soakage”.

It is vitally important that you ensure the capacitor is fully discharged (ideally for several seconds) to minimise the possibility of damage to the unit.

If you are unsure, measure the voltage across the capacitor using a suitable volt meter before applying the capacitor to the Atlas LCR.

 Generally, tantalum capacitors and electrolytic capacitors are polarised. The Atlas LCR, however, uses a maximum of 1V to test the capacitor and so polarity of the Atlas LCR test probes is (usually) unimportant.

## Testing Resistors

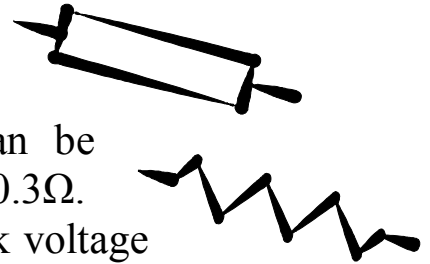

Resistance values ranging from  $0.5\Omega$  to  $2M\Omega$  can be measured, with a minimum resolution of about  $0.3\Omega$ .

Resistance is measured using a DC signal with a peak voltage of 1V (across an open circuit) and a peak current of about 3mA (through a short circuit).

**Resistor results:** Following analysis, the resistance value is displayed.

Resistance  
332.2k

## Low Resistance/Inductance

Low value inductors ( $<5\mu\text{H}$ ) and low value resistors ( $<10\Omega$ ) are treated as a special case by the Atlas LCR. This is because low value inductors and low value resistors can exhibit very similar characteristics at the test frequencies available from the Atlas LCR.

The following message is displayed:

Pressing the **scroll-off** button will display the values of resistance and inductance that the Atlas LCR has measured.

The test frequency displayed is the frequency used for the measurement of the inductance.

Low Resistance  
and Inductance

Resistance  
1.3 ohms

Inductance  
0.6uH

Test frequency  
200kHz

 Please note that probe compensation is particularly important when analysing low value inductors, capacitors and resistors.

## Taking care of your Atlas LCR

---

### Battery Replacement

The Atlas LCR requires no special maintenance although the battery should be replaced every 12 months to prevent leak damage.

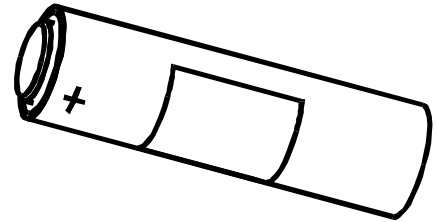

**\* Low Battery \***

If this message is displayed, the battery should be replaced as soon as possible to prevent malfunction or leak damage.

Although the unit may continue to operate following a low battery warning, measurements may be adversely affected.

New batteries can be purchased from many retailers and directly from Peak Electronic Design Ltd or an authorised agent.

**Battery types:** Suitable battery types include 23A, V23A, GP23A, MN21 or a good quality 12V alkaline equivalent as used in many test instruments and automotive remote key fobs.

**Battery access:** To replace the battery, unscrew the three screws to remove the rear panel. Remove the old battery and insert a new one, taking care to observe the correct polarity. Carefully replace the rear panel, do not over-tighten the screws.

**Peak Safe Battery Disposal Scheme:** Please return your old analyser battery to Peak Electronic Design Ltd for safe and environmentally responsible disposal.

## Self Tests

Many internal functions are tested each time the unit is powered up. If any of these self tests do not meet tight performance limits, a message will be displayed similar to the following:



**Error 02**

The unit will then switch off.

It is possible that a temporary condition caused the failure and restarting the unit may clear the problem. If the fault persists please contact Peak Electronic Design Ltd or an authorised agent with details of the error message for further advice.

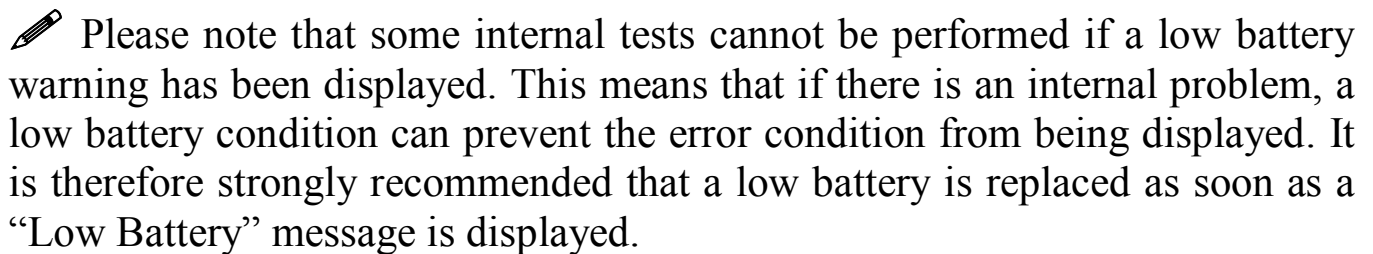

 Please note that some internal tests cannot be performed if a low battery warning has been displayed. This means that if there is an internal problem, a low battery condition can prevent the error condition from being displayed. It is therefore strongly recommended that a low battery is replaced as soon as a “Low Battery” message is displayed.



## **Appendix A – Accessories**

---

A range of useful additions is available to enhance your Atlas LCR.

### **Carry Case**

A specially designed case with custom made foam compartments and a smart tough exterior is ideal for protecting your Atlas LCR and probes. There's even space for a spare battery.

### **SMD Tweezer Probes**

These tweezers are ideal for testing many types of surface mount device. The tweezers can cope with package sizes of 0402, 0603, 0805, 1206, 1210 and Case A/B/C/D.

Fitting is easy: the tweezers are terminated in the standard Atlas LCR probe connectors.

### **Other Probe Accessories**

Many different probe types are available, specially made for your Atlas LCR. Contact Peak Electronic Design Ltd or an authorised agent for more details.

## Appendix B - Component Identification

It is important to appreciate that the Atlas LCR can only decide on the identity of the component under test using results of the electrical tests that it performs on the component.

The Atlas LCR determines the type of component under test according to the following criteria:

### Inductor and Resistor Detection

The Atlas LCR will distinguish between components that are largely inductive or largely resistive according to the values of inductance and resistance that it has measured. This is illustrated in the following graph.

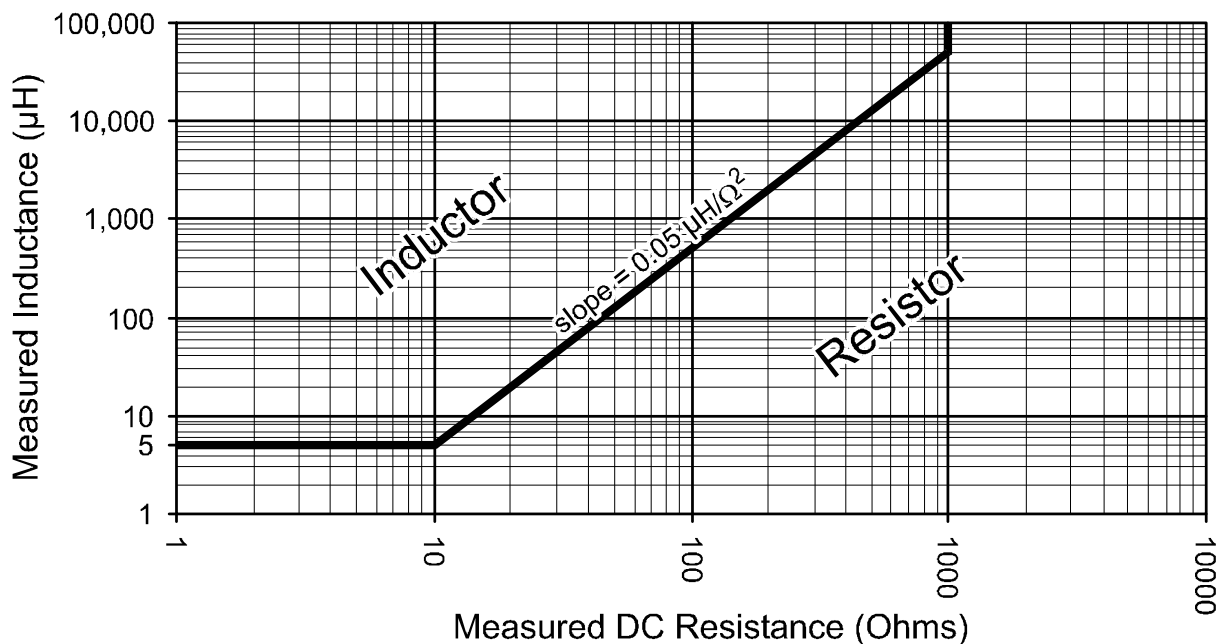

For example, if the inductance of your component is measured at  $100\mu\text{H}$  and it has a DC resistance of  $100\Omega$ , then the Atlas LCR will tell you that you have a resistor. If however the resistance was only  $10\Omega$ , then the Atlas LCR will tell you that you have an inductor.

Note that any inductor with a DC resistance of more than  $1000\Omega$  will be identified as a resistor.

## Capacitor Detection

The Atlas LCR will tell you that you have a capacitor if the following criteria are satisfied:

1. If the measured DC resistance is higher than  $10\text{M}\Omega$ , even if the measured capacitance is very low (such as open probes).

or

2. If the measured DC resistance is between  $100\text{k}\Omega$  and  $10\text{M}\Omega$  and the measured capacitance is larger than  $10\text{pF}$ .

or

3. If the measured DC resistance is between  $1\text{k}\Omega$  and  $100\text{k}\Omega$  and the measured capacitance is larger than  $100\text{nF}$ .

## Resistor Detection

Measured characteristics that do not satisfy any of the above criteria (for inductors or capacitors) will be displayed as a resistive element.

## Appendix C – Technical Specifications

Parameter		Min	Typ	Max	Note
Resistance	range	1Ω		2MΩ	
	resolution	0.3 Ω	0.6Ω		
	accuracy	Typically ±1.0% ±1.2Ω			1,2,6
Capacitance	range	0.5pF		10,000μF	
	resolution	0.2pF	0.5pF		
	accuracy	Typically ±1.5% ±1.0pF			1,2,5
Inductance	range	1μH		10H	
	resolution	0.4μH	0.8μH		
	accuracy	Typically ±1.5% ±1.6μH			1,2,4
Peak test voltage (across O/C)		-1.05V		+1.05V	
Peak test current (thru S/C)		-3.25mA		+3.25mA	
Test frequency accuracy	1kHz	-1.5%	±1%	+1.5%	
	14.925kHz	-1.5%	±1%	+1.5%	
	200kHz	-1.5%	±1%	+1.5%	
Sine purity		Typically -60dB 3 <sup>rd</sup> harmonic			
Operating temperature range		10°C		40°C	3
Battery operating voltage		8.5V		13V	

### Notes:

1. Within 12 months of factory calibration. Please contact us if you require a full re-calibration and/or certification of traceable calibration.
2. Specified at temperatures between 15°C and 30°C.
3. Subject to acceptable LCD visibility.
4. For inductances between 100μH and 100mH.
5. For capacitances between 200pF and 500nF.
6. For resistances between 10Ω and 1MΩ.

## Appendix D – Troubleshooting

Problem	Possible Solution
Capacitance measured when probes are open circuit is not close to zero ( $\pm 1.0\text{pF}$ ).	Perform a probe compensation.
Resistance and/or inductance measured when probes are short circuit is not close to zero ( $\pm 1.2\Omega$ , $\pm 1.6\mu\text{H}$ ).	Perform a probe compensation.
Measured value doesn't appear to be correct.	Ensure probes are well connected to the component under test for the <u>entire duration</u> of the analysis.
	Ensure that nothing else is connected with the component under test. Make sure that you are not touching the connections.
	The component value may be outside the supported measurement range.
	The component's design frequency may not correspond to the test frequencies used by the Atlas LCR.
Measured values vary slightly between tests.	The displayed resolution is higher than the measurement resolution to avoid rounding errors. Small variations within the quoted measurement resolutions are normal.
Calibration date is approaching or has past.	Don't worry, the Atlas LCR will carry on working after the "Calibration Due Date" has past. The date is simply a recommendation.

## **Appendix E – Warranty Information**

---

### **Peak Satisfaction Guarantee**

If for any reason you are not completely satisfied with the Peak Atlas LCR within 14 days of purchase you may return the unit to your distributor. You will receive a refund covering the full purchase price if the unit is returned in perfect condition.

### **Peak Warranty**

The warranty is valid for 24 months from date of purchase. This warranty covers the cost of repair or replacement due to defects in materials and/or manufacturing faults.

The warranty does not cover malfunction or defects caused by:

- a) Operation outside the scope of the user guide.
- b) Unauthorised access or modification of the unit (except for battery replacement).
- c) Accidental physical damage or abuse.
- d) Normal wear and tear.

The customer's statutory rights are not affected by any of the above.

All claims must be accompanied by a proof of purchase.

## Appendix F – Disposal Information

---



### **WEEE (Waste of Electrical and Electronic Equipment), Recycling of Electrical and Electronic Products**

#### **United Kingdom**

In 2006 the European Union introduced regulations (WEEE) for the collection and recycling of all waste electrical and electronic equipment. It is no longer permissible to simply throw away electrical and electronic equipment. Instead, these products must enter the recycling process.

Each individual EU member state has implemented the WEEE regulations into national law in slightly different ways. Please follow your national law when you want to dispose of any electrical or electronic products.

**More details can be obtained from your national WEEE recycling agency.**

If in doubt, you may send your Peak Product to us for safe and environmentally responsible disposal.

At Peak Electronic Design Ltd we are committed to continual product development and improvement. The specifications of our products are therefore subject to change without notice.

© 2002-2012 Peak Electronic Design Limited - E&OE  
Designed and manufactured in the UK  
www.peakelec.co.uk Tel. +44 (0) 1298 70012 Fax. +44 (0) 1298 70046

## **X-ON Electronics**

Largest Supplier of Electrical and Electronic Components

*Click to view similar products for [peak manufacturer](#):*

Other Similar products are found below :

[ELSM](#) [IDT8A](#) [RJA11](#) [ATC55](#) [UTP05](#) [LLSM](#) [PCA23](#) [CRC01](#) [CRC01M](#) [IDT8B](#) [IDT8C](#) [ATPK3](#) [PAT02](#) [UPS56](#) [LCD02](#) [LCRLHP2](#)  
[IDTN](#) [ENP90](#) [ATC02](#) [DCA75](#) [LCR-40](#) [ESR70](#)