



PEM® KEYHOLE® fasteners are designed for quick panel attachment and reduction of loose hardware.

NEW - SKS-R™ Fasteners
Provide high side-load in verticle component mounting applications



SK™

**SELF-CLINCHING
KEYHOLE® FASTENERS**

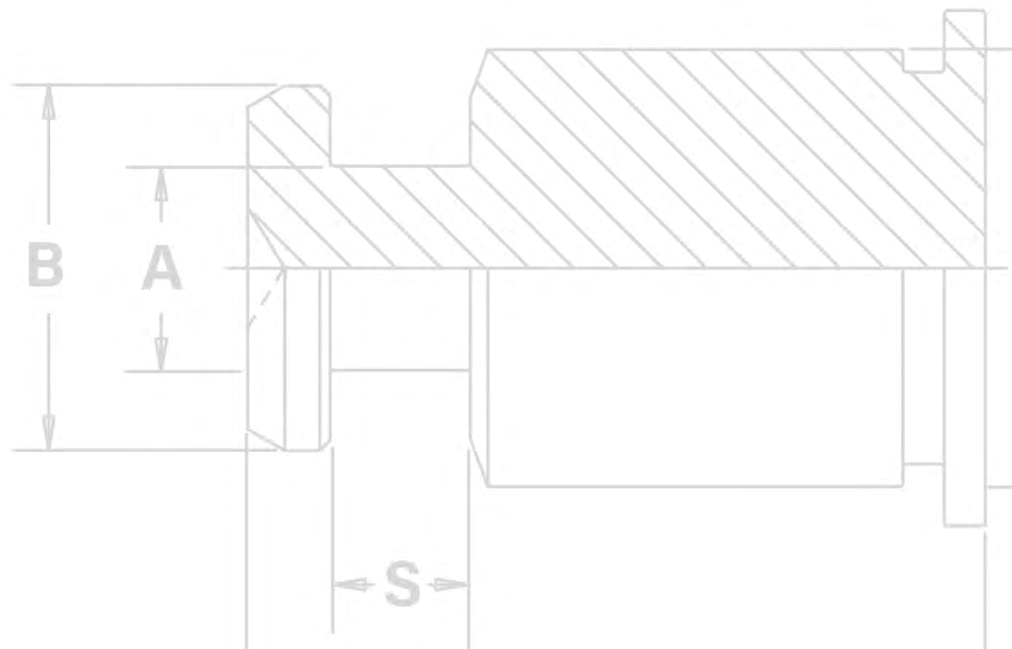

KEYHOLE® STANDOFFS AND FASTENERS

PEM® KEYHOLE® Standoffs and sheet joining fasteners are designed so that a PC board or panel can be quickly slipped into place and then removed from an assembly by simply sliding the board sideways and lifting it off. These standoffs and fasteners can save valuable time and dramatically reduce the amount of loose hardware required.

SKC™/SK4™ standoffs can be used for spacing or mounting of replaceable components. Typically, several standoffs are used with one standard PEM® threaded standoff which accepts a screw to secure the board or component against any unwanted movement.

- Allow detachable spacing of two sheets
- Clinch feature mounts fastener permanently and flush into metal sheet
- Unique barrel design allows for quick attachment and detachment
- Makes horizontal or vertical component mounting possible
- SK4™ standoffs are available for installation into stainless steel sheets

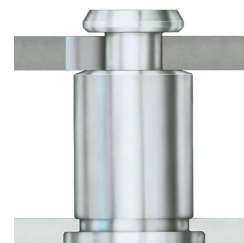

SKC-F™/SK4-F™/SKS-R™ fasteners are designed so that two sheets can be quickly joined flat against each other. Typically, several fasteners are used with one standard PEM® threaded F™ flush nut ([PEM® Bulletin F](#)) which accepts a screw to secure the sheets against any unwanted movement.

- Allow detachable spacing of two sheets
- Clinch feature mounts fastener permanently and flush or sub-flush into metal sheet
- Unique barrel design allows for quick "panel-on-panel" attachment and detachment
- Can be clinched into blind hole where concealed head is required
- Makes horizontal or vertical component mounting possible
- SK4-F™ fasteners are available for installation into stainless steel sheets
- SKS-R™ fasteners are designed to provide high side-load in vertical component mounting applications
- SKS-R™ fasteners are available for various top sheet thicknesses and hole sizes



SKC-F™/SK4-F™ Fasteners



SKS-R™ Fasteners



SKC™/SK4™ Standoffs



SKC-F™/SK4-F™ Fasteners

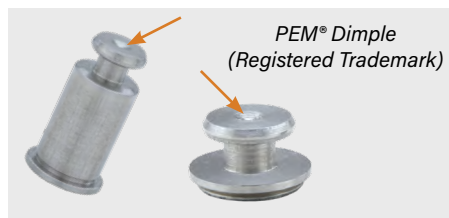
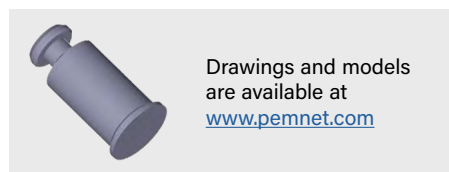

KEYHOLE® STANDOFFS AND FASTENERS

SKC™/SK4™ STANDOFF DIMENSIONAL DATA

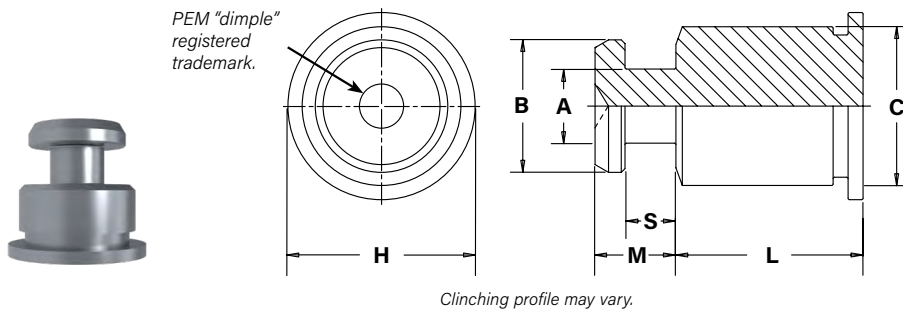

PART NUMBER DESIGNATION

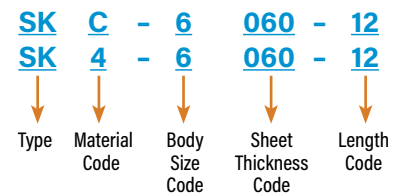

All dimensions are in inches.

UNIFIED	Type		Body Size - Sheet Code	Length "L" ± .005 (Length Code in 32nds of an inch)													A	B	C	S	M	H
	300 Series Stainless Steel	400 Series Stainless Steel		.063	.125	.188	.250	.312	.375	.437	.500	.562	.625	.750	.875	1.00	± .003	± .003	Max.	± .003	Max.	Nom.
	SKC	SK4	6060	2	4	6	8	10	12	14	16	18	20	24	28	32	.099	.177	.212	.068	.108	.250

All dimensions are in millimeters.

METRIC	Type		Body Size - Sheet Code	Length "L" ± 0.13 (Length Code in millimeters)													A	B	C	S	M	H
	300 Series Stainless Steel (1)	400 Series Stainless Steel (2)		2	4	6	8	10	12	14	16	18	20	22	25	± 0.08	± 0.08	Max.	± 0.08	Max.	Nom.	
	SKC	SK4	61.5	2	4	6	8	10	12	14	16	18	20	22	25	2.51	4.5	5.39	1.73	2.75	6.35	

SKC-F™/SK4-F™ FASTENER DIMENSIONAL DATA

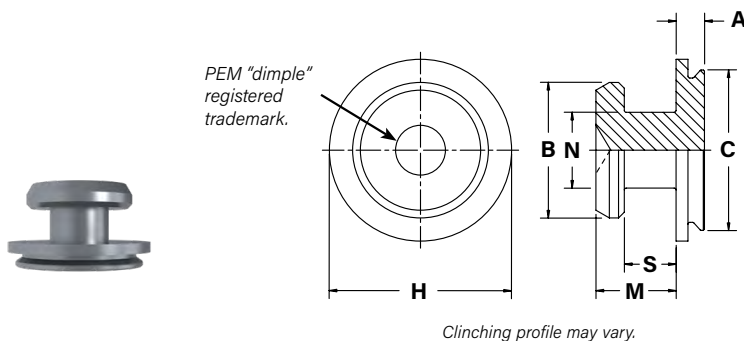

PART NUMBER DESIGNATION

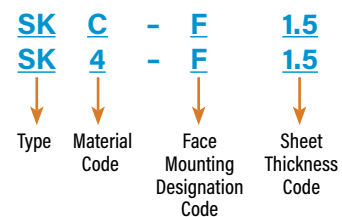

All dimensions are in inches.

UNIFIED	Type		Face Mounting Designation Code	Top Sheet Thickness Code	A	B	C	H	M	N	S
	300 Series Stainless Steel	400 Series Stainless Steel			Max.	± .003	Max.	Nom.	Max.	± .003	± .003
	SKC	SK4	F	1.5	.039	.177	.212	.237	.108	.099	.068

All dimensions are in millimeters.

METRIC	Type		Face Mounting Designation Code	Top Sheet Thickness Code	A	B	C	H	M	N	S
	300 Series Stainless Steel	400 Series Stainless Steel			Max.	± 0.08	Max.	Nom.	Max.	± 0.08	± 0.08
	SKC	SK4	F	1.5	1	4.5	5.39	6.02	2.75	2.5	1.73



NEW

SKS-R™ FASTENER DIMENSIONAL DATA

PART NUMBER DESIGNATION

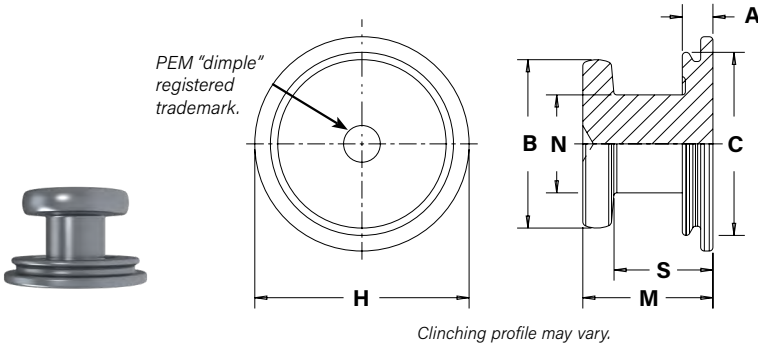
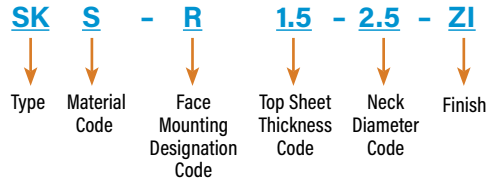

All dimensions are in inches.

UNIFIED	Type	Face Mounting Designation Code	Top Sheet Thickness Code	Neck Diameter Code	A (Shank) Max.	B ±.003	C Max.	H Nom.	M Max.	N ±.003	S +.003 - .008
	Hardened Steel										
UNIFIED	SKS	R	1.5	2.5	.039	.177	.212	.236	.148	.099	.107
				3.2		.217	.235	.276		.126	
				4.0		.256	.275	.307		.157	
	SKS	R	2	2.5	.039	.177	.212	.236	.167	.099	.127
				3.2		.217	.235	.276		.126	
				4.0		.256	.275	.307		.157	
	SKS	R	2.5	2.5	.039	.177	.212	.236	.187	.099	.147
				3.2		.217	.235	.276		.126	
				4.0		.256	.275	.307		.157	

All dimensions are in millimeters.

MILLIMETERS	Type	Face Mounting Designation Code	Top Sheet Thickness Code	Neck Diameter Code	A (Shank) Max.	B ±0.08	C Max.	H Nom.	M Max.	N ±0.08	S +0.08 -0.21
	Hardened Steel										
MILLIMETERS	SKS	R	1.5	2.5	1	4.5	5.39	6	3.75	2.5	2.73
				3.2		5.5	5.98	7		3.2	
				4.0		6.5	6.98	7.8		4	
	SKS	R	2	2.5	1	4.5	5.39	6	4.25	2.5	3.23
				3.2		5.5	5.98	7		3.2	
				4.0		6.5	6.98	7.8		4	
	SKS	R	2.5	2.5	1	4.5	5.39	6	4.75	2.5	3.73
				3.2		5.5	5.98	7		3.2	
				4.0		6.5	6.98	7.8		4	



APPLICATION DATA

SKC™/SK4™ STANDOFF

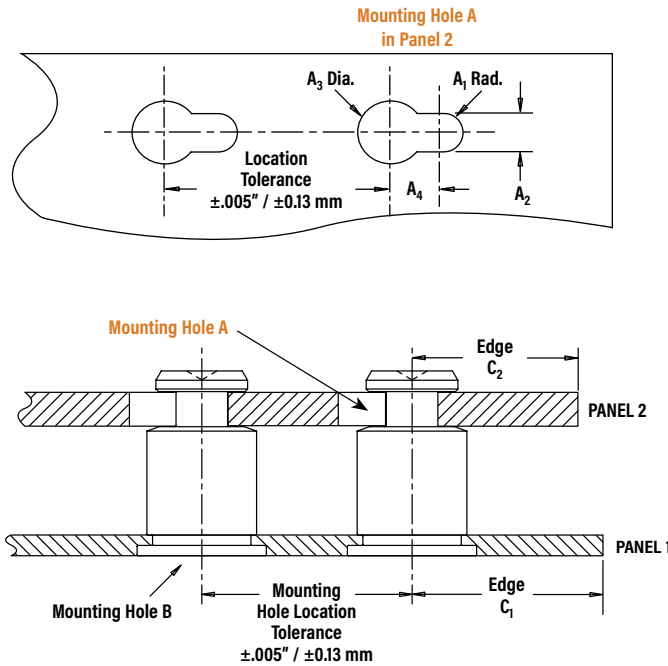

SKC-F™/SK4-F™ FASTENER

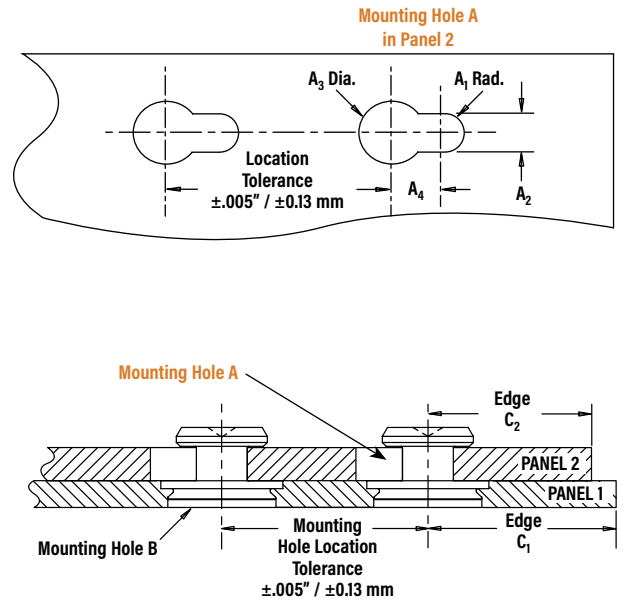

All dimensions are in inches.

UNIFIED	Type	PANEL 1				PANEL 2						
		Bottom Mounting Hole B +.003 -.000	Sheet Hardness Max. (1)	Min. Sheet Thickness	Edge Distance C ₁ Min.	Top Mounting Hole A				Material	Thickness Range	Edge Distance C ₂ Min.
						A ₁ Nom.	A ₂ ±.003	A ₃ ±.003	A ₄ Min.			
	SKC-6060	.213	HRB 70 / HB 125	.040	.260	.059	.118	.197	.148	ANY	.057 - .064	.160
	SK4-6060	.213	HRB 88 / HB 183	.040	.260	.059	.118	.197	.148	ANY	.057 - .064	.160
	SKC-F1.5	.213	HRB 70 / HB 125	.040 ⁽²⁾	.150	.059	.118	.197	.148	ANY	.057 - .064	.160
	SK4-F1.5	.213	HRB 88 / HB 183	.040 ⁽²⁾	.150	.059	.118	.197	.148	ANY	.057 - .064	.160

All dimensions are in millimeters.

METRIC	Type	PANEL 1				PANEL 2						
		Bottom Mounting Hole B +0.08	Sheet Hardness Max. (1)	Min. Sheet Thickness	Edge Distance C ₁ Min.	Top Mounting Hole A				Material	Thickness Range	Edge Distance C ₂ Min.
						A ₁ Nom.	A ₂ ± 0.08	A ₃ ± 0.08	A ₄ Min.			
	SKC-61.5	5.41	HRB 70 / HB 125	1	6.6	1.5	3	5	3.75	ANY	1.45 - 1.62	4.1
	SK4-61.5	5.41	HRB 88 / HB 183	1	6.6	1.5	3	5	3.75	ANY	1.45 - 1.62	4.1
	SKC-F1.5	5.41	HRB 70 / HB 125	1 ⁽²⁾	3.8	1.5	3	5	3.75	ANY	1.45 - 1.62	4.1
	SK4-F1.5	5.41	HRB 88 / HB 183	1 ⁽²⁾	3.8	1.5	3	5	3.75	ANY	1.45 - 1.62	4.1

(1) HRB - Hardness Rockwell "B" Scale. HB - Hardness Brinell.

(2) SKC-F™/SK4-F™ fasteners may also be installed into a .043" / 1.1 mm minimum depth blind milled hole in a .062" / 1.6 mm minimum sheet thickness.

APPLICATION DATA

SKS-R™ FASTENER

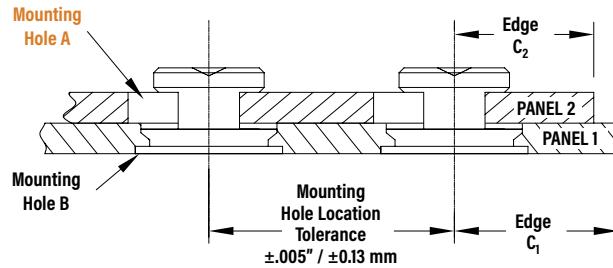
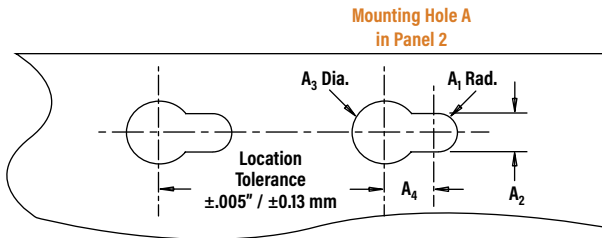

All dimensions are in inches.

UNIFIED	PANEL 1				PANEL 2							
	Type	Bottom Mounting Hole B +.003-.000	Sheet Hardness Max. (1)	Thickness Range	Edge Distance C ₁ Min.	Top Mounting Hole A				Material	Thickness Max.	Edge Distance C ₂ Min.
						A ₁ Nom.	A ₂ ±.003	A ₃ ±.003	A ₄ Min.			
SKS-R1.5-2.5-ZI	.213	HRB 80 / HB 150	.040 - .047	.236	.059	.118	.197	.148	ANY	.060	.160	
SKS-R1.5-3.2-ZI	.236	HRB 80 / HB 150	.040 - .047	.236	.073	.146	.236	.181	ANY	.060	.201	
SKS-R1.5-4.0-ZI	.276	HRB 80 / HB 150	.040 - .047	.236	.089	.177	.276	.217	ANY	.060	.240	
SKS-R2.0-2.5-ZI	.213	HRB 80 / HB 150	.040 - .047	.236	.059	.118	.197	.148	ANY	.080	.160	
SKS-R2.0-3.2-ZI	.236	HRB 80 / HB 150	.040 - .047	.236	.073	.146	.236	.181	ANY	.080	.201	
SKS-R2.0-4.0-ZI	.276	HRB 80 / HB 150	.040 - .047	.236	.089	.177	.276	.217	ANY	.080	.240	
SKS-R2.5-2.5-ZI	.213	HRB 80 / HB 150	.040 - .047	.236	.059	.118	.197	.148	ANY	.100	.160	
SKS-R2.5-3.2-ZI	.236	HRB 80 / HB 150	.040 - .047	.236	.073	.146	.236	.181	ANY	.100	.201	
SKS-R2.5-4.0-ZI	.276	HRB 80 / HB 150	.040 - .047	.236	.089	.177	.276	.217	ANY	.100	.240	

All dimensions are in millimeters.

MILLIMETERS	PANEL 1				PANEL 2							
	Type	Bottom Mounting Hole B + 0.08	Sheet Hardness Max. (1)	Thickness Range	Edge Distance C ₁ Min.	Top Mounting Hole A				Material	Thickness Max.	Edge Distance C ₂ Min.
						A ₁ Nom.	A ₂ ± 0.08	A ₃ ± 0.08	A ₄ Min.			
SKS-R1.5-2.5-ZI	5.41	HRB 80 / HB 150	1 - 1.19	6	1.5	3	5	3.75	ANY	1.54	4.1	
SKS-R1.5-3.2-ZI	6	HRB 80 / HB 150	1 - 1.19	6	1.85	3.7	6	4.6	ANY	1.54	5.1	
SKS-R1.5-4.0-ZI	7	HRB 80 / HB 150	1 - 1.19	6	2.25	4.5	7	5.5	ANY	1.54	6.1	
SKS-R2.0-2.5-ZI	5.41	HRB 80 / HB 150	1 - 1.19	6	1.5	3	5	3.75	ANY	2.04	4.1	
SKS-R2.0-3.2-ZI	6	HRB 80 / HB 150	1 - 1.19	6	1.85	3.7	6	4.6	ANY	2.04	5.1	
SKS-R2.0-4.0-ZI	7	HRB 80 / HB 150	1 - 1.19	6	2.25	4.5	7	5.5	ANY	2.04	6.1	
SKS-R2.5-2.5-ZI	5.41	HRB 80 / HB 150	1 - 1.19	6	1.5	3	5	3.75	ANY	2.54	4.1	
SKS-R2.5-3.2-ZI	6	HRB 80 / HB 150	1 - 1.19	6	1.85	3.7	6	4.6	ANY	2.54	5.1	
SKS-R2.5-4.0-ZI	7	HRB 80 / HB 150	1 - 1.19	6	2.25	4.5	7	5.5	ANY	2.54	6.1	

INSTALLATION

SKC™/SK4™ STANDOFFS

1. Prepare properly sized mounting hole in Panel 1.
2. Place the fastener through (punched side of) the mounting hole and into anvil as shown in figure 1.
3. With installation punch and anvil surfaces parallel, apply only enough squeezing force to embed the head flush with the panel.

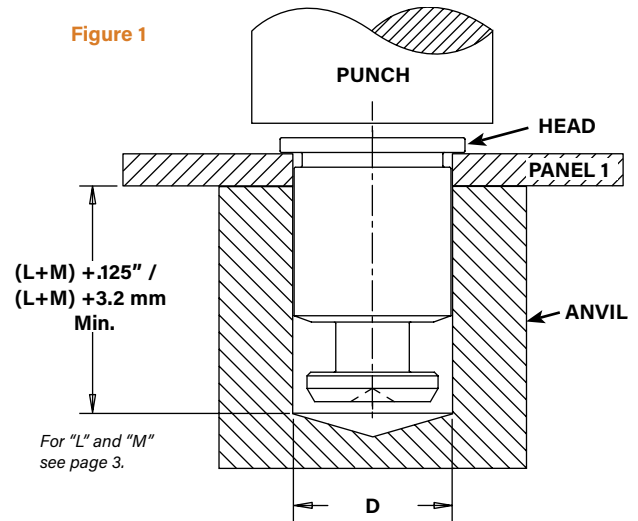

PEMSERTER® Installation Tooling

UNIFIED	Body Size Sheet Code	Anvil Dimension (in.)		Anvil Part Number	Punch Part Number
		D	+0.003 -.000		
	6060	.216		970200012300	975200048

METRIC	Body Size Sheet Code	Anvil Dimension (mm)		Anvil Part Number	Punch Part Number
		D	+0.08		
	61.5	5.49		970200012300	975200048

SKC-F™/SK4-F™ FASTENERS

Through Hole Installation Procedure

1. Prepare properly sized mounting hole in Panel 1.
2. Place the fastener into anvil hole as shown in Figure 2.
3. Place the (punch side of) mounting hole over the shank of the fastener.
4. With installation punch and anvil surfaces parallel, apply only enough squeezing force until flange is flush with panel.

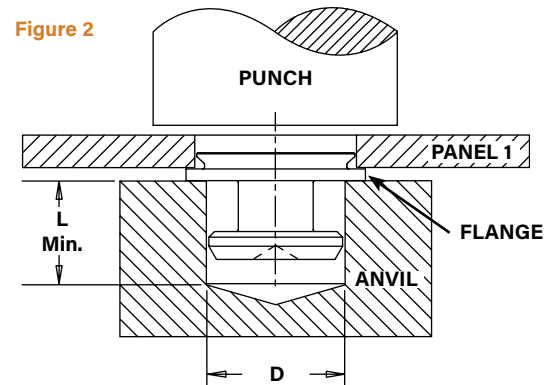

Blind Hole Installation Procedure

1. Mill a properly sized blind hole into Panel 1 to .043"/1.1 mm minimum depth.
2. Place the fastener into anvil hole as shown in Figure 3.
3. Place the panel mounting hole over the shank of the fastener.
4. With installation punch and anvil surfaces parallel, apply only enough squeezing force to embed the flange flush with the panel.

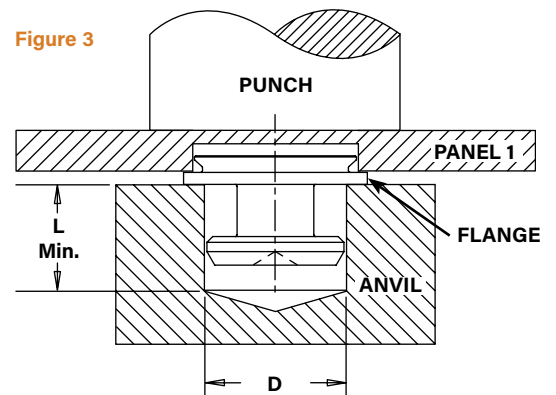

PEMSERTER® Installation Tooling

UNIFIED	Sheet Thickness Code	Anvil Dimensions (in.)		Anvil Part Number	Punch Part Number
		L Min.	D		
	1.5	.233	.184	8012608	975200048

METRIC	Sheet Thickness Code	Anvil Dimensions (mm)		Anvil Part Number	Punch Part Number
		L Min.	D		
	1.5	5.95	4.67	8012608	975200048

End Mill Information

Double-ended, two-flute H.S.S. center-cutting end mills are available from stock. PennEngineering does not manufacture center-cutting end mills, but we do keep a supply in stock for your convenience.



Fastener Type	Required Size End Mill	PEM Part No.
SKC-F/SK4-F	.213"	CHM-213



SKS-R™ FASTENERS

1. Prepare properly sized mounting hole in Panel 1.
2. Place the fastener through (punch side of) the mounting hole and into anvil as shown.
3. With installation punch and anvil surfaces parallel, apply only enough squeezing force to embed the head flush with the panel.

PEMSERTER® Installation Tooling

UNIFIED	Neck Diameter Code	Anvil Dimensions (in.) D +.003 -.000	Anvil Part Number	Punch Part Number
	25	.183	8026244	975200048
32	.222	8026245		
40	.262	8026246		

METRIC	Neck Diameter Code	Anvil Dimensions (mm) D +0.08	Anvil Part Number	Punch Part Number
	25	4.65	8026244	975200048
32	5.65	8026245		
40	6.65	8026246		

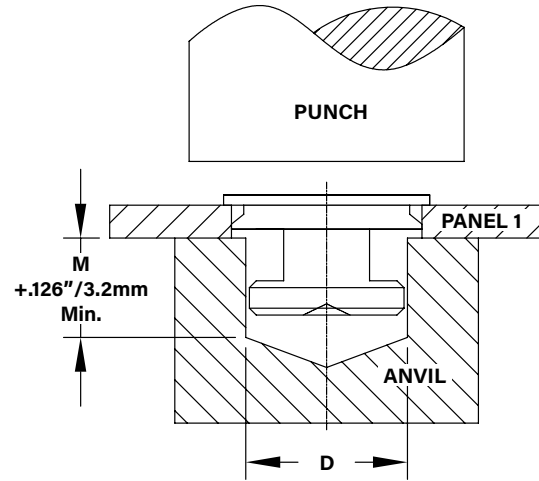

INSTALLATION NOTES

- For best results we recommend using a [HAEGER®](#) or PEMSERTER® machine for installation of PEM® self-clinching fasteners. Please check our website for more information.
- Visit the Animation Library on our website to view the installation process [for select products](#).

MATERIAL AND FINISH SPECIFICATIONS

Type	Fastener Materials			Standard Finish		For Use in Sheet Hardness: ⁽¹⁾		
	Hardened Steel	300 Series Stainless Steel	Hardened 400 Series Stainless Steel	Passivated and/or Tested per ASTM A380	Zinc Plated per ASTM B633, SC1 (5um) Type III, Colorless ⁽²⁾	HRB 88 / HB 183 or less	HRB 80 / HB 150 or less	HRB 70 / HB 125 or less
SKC		▪		▪				▪
SK4			▪	▪		▪		
SKC-F		▪		▪				▪
SC4-F			▪	▪		▪		
SKS-R	▪				▪		▪	
Part Number Code For Finishes				None	ZI			

(1) HRB - Hardness Rockwell "B" Scale. HB - Hardness Brinell.

(2) See PEM Technical Support section of our web site for related plating standards and specifications.

A NOTE ABOUT 400 SERIES FASTENERS FOR STAINLESS STEEL PANELS

In order for self-clinching fasteners to work properly, the fastener must be harder than the sheet into which it is being installed. In the case of stainless steel panels, fasteners made from 300 Series Stainless Steel do not meet this hardness criteria. It is for this reason that 400 series fasteners (SK4 and SK4-F) are offered. However, while these 400 Series fasteners install and perform well in 300 Series stainless sheets they should not be used if the end product:

- Will be exposed to any appreciable corrosive presence.
- Requires non-magnetic fasteners.
- Will be exposed to any temperatures above 300°F (149°C)

If any of these are issues, please contact techsupport@pemnet.com for other options.

PERFORMANCE DATA⁽¹⁾

SKC™/SK4™ STANDOFFS

Installation and pushout

Test Sheet Material →		.060" 5052-H34 Aluminum		.060" Cold-Rolled Steel		.060" 300 Series Stainless Steel	
UNIFIED	Body Size - Sheet Code	Installation (lbs.)	Pushout (lbs.)	Installation (lbs.)	Pushout (lbs.)	Installation (lbs.)	Pushout (lbs.)
	SKC-6060	1600	250	3200	600	—	—
	SK4-6060	—	—	—	—	9015	720

Test Sheet Material →		1.52 mm 5052-H34 Aluminum		1.52 mm Cold-Rolled Steel		1.52 mm 300 Series Stainless Steel	
METRIC	Body Size - Sheet Code	Installation (kN)	Pushout (N)	Installation (kN)	Pushout (N)	Installation (kN)	Pushout (N)
	SKC-61.5	71	1100	14.2	2600	—	—
	SK4-61.5	—	—	—	—	40.1	3200

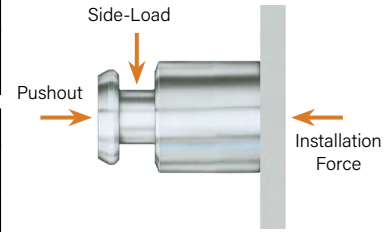

SKC™/SK4™ STANDOFFS

Side-load

		Test Sheet Thick. →	.040" ⁽²⁾		.060"										
UNIFIED	Body Size - Sheet Code	Test Sheet Material	Length Codes												
			-2	-4	-6	-8	-10	-12	-14	-16	-18	-20	-24	-28	-32
	Side-Load Force Max. (lbs.)														
	SKC-6060	5052-H34 Aluminum	130	95	82	63	52	44	38	34	30	27	22	19	17
SKC-6060	Cold-Rolled Steel	185	120	197	153	126	106	92	81	71	66	55	47	42	
SK4-6060	300 Series Stainless Steel	400	300	220	180	160	140	120	110	100	100	80	70	50	

		Test Sheet Thick. →	1 mm ⁽²⁾		1.52 mm										
METRIC	Body Size - Sheet Code	Test Sheet Material	Length Codes												
			-2	-4	-6	-8	-10	-12	-14	-16	-18	-20	-22	-25	
	Side-Load Force Max. (N)														
	SKC-61.5	5052-H34 Aluminum	545	370	296	228	184	156	136	116	104	96	88	76	
SKC-61.5	Cold-Rolled Steel	735	490	696	540	440	372	320	280	252	228	208	184		
SK4-61.5	300 Series Stainless Steel	1690	1140	860	710	610	540	480	440	400	380	320	250		

SKC-F™/SK4-F™ FASTENERS

Installation, Pushout and Side-load

Test Sheet Material →		.060" 5052-H34 Aluminum			.060" Cold-Rolled Steel			.060" 300 Series Stainless Steel		
UNIFIED	Type	Installation (lbs.)	Pushout (lbs.)	Side-Load Force Max. (lbs.)	Installation (lbs.)	Pushout (lbs.)	Side-Load Force Max. (lbs.)	Installation (lbs.)	Pushout (lbs.)	Side-Load Force Max. (lbs.)
	SKC-F	1100	120	120	2100	160	185	—	—	—
	SK4-F	—	—	—	—	—	—	10210	292	202

Test Sheet Material →		1.52 mm 5052-H34 Aluminum			1.52 mm Cold-Rolled Steel			1.52 mm 300 Series Stainless Steel		
METRIC	Type	Installation (kN)	Pushout (N)	Side-Load Force Max. (N)	Installation (kN)	Pushout (N)	Side-Load Force Max. (N)	Installation (kN)	Pushout (N)	Side-Load Force Max. (N)
	SKC-F	4.9	533	533	9.3	711	822	—	—	—
	SK4-F	—	—	—	—	—	—	45.4	1300	900

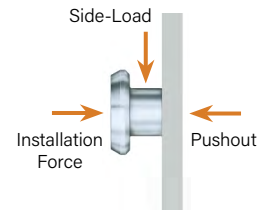

(1) Published installation forces are for general reference. Actual set-up and confirmation of complete installation should be made by observing proper seating of fastener as described in the installation steps. Other performance values reported are averages when all proper installation parameters and procedures are followed. Variations in mounting hole size, sheet material, and installation procedure may affect performance. Performance testing this product in your application is recommended. We will be happy to provide technical assistance and/or samples for this purpose.

(2) .040" / 1 mm test sheet material thickness was used for the -2 and -4 SKC/SK4 standoffs due to the short length of the parts.

PERFORMANCE DATA

SKS-R™ FASTENERS

Installation, Pushout and Side-load

Test Sheet Material →		.040" Cold-Rolled Steel HRB 67		
UNIFIED	Type	Installation (lbs.)	Pushout (lbs.)	Side-Load Force Max. (lbs.)
	SKS-R1.5-2.5-ZI	3200	160	191
	SKS-R1.5-3.2-ZI	4000	180	213
	SKS-R1.5-4.0-ZI	5000	180	258
	SKS-R2.0-2.5-ZI	3200	160	169
	SKS-R2.0-3.2-ZI	4000	180	191
	SKS-R2.0-4.0-ZI	5000	180	225
	SKS-R2.5-2.5-ZI	3200	160	124
	SKS-R2.5-3.2-ZI	4000	180	137
	SKS-R2.5-4.0-ZI	5000	180	182

Test Sheet Material →		1 mm Cold-Rolled Steel HRB 67		
METRIC	Type	Installation (kN)	Pushout (N)	Side-Load Force Max. (N)
	SKS-R1.5-2.5-ZI	14.2	711	850
	SKS-R1.5-3.2-ZI	17.8	800	950
	SKS-R1.5-4.0-ZI	22.3	800	1150
	SKS-R2.0-2.5-ZI	14.2	711	750
	SKS-R2.0-3.2-ZI	17.8	800	850
	SKS-R2.0-4.0-ZI	22.3	800	1000
	SKS-R2.5-2.5-ZI	14.2	711	550
	SKS-R2.5-3.2-ZI	17.8	800	610
	SKS-R2.5-4.0-ZI	22.3	800	810

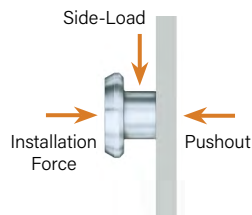

All PEM® products meet our stringent quality standards. If you require additional industry or other specific [quality certifications](#), special procedures and/or part numbers are required. Please contact your local sales office or representative for further information.

Regulatory [compliance information](#) is available in Technical Support section of our website. Specifications subject to change without notice. See our website for the most current version of this bulletin.

PennEngineering®



North America: Danboro, Pennsylvania USA ▪ E-mail: info@pemnet.com ▪ Tel: +1-215-766-8853 ▪ 800-237-4736 (USA)

Europe: Galway, Ireland ▪ E-mail: europa@pemnet.com ▪ Tel: +353-91-751714

Asia/Pacific: Singapore ▪ E-mail: singapore@pemnet.com ▪ Tel: +65-6-745-0660

Shanghai, China ▪ E-mail: china@pemnet.com ▪ Tel: +86-21-5868-3688

Visit our PEMNET™ Resource Center at www.pemnet.com ▪ Technical support e-mail: techsupport@pemnet.com

X-ON Electronics

Largest Supplier of Electrical and Electronic Components

Click to view similar products for [Screws & Fasteners](#) category:

Click to view products by [PEM manufacturer](#):

Other Similar products are found below :

[5721-1440-1/4-SS](#) [0098.0094](#) [0098.9206](#) [0098.9219](#) [0098.9221](#) [59781-6](#) [0098.9212](#) [618-00001](#) [6292-1](#) [690432-1](#) [699161-000](#) [700989](#)
[7230-3](#) [72609-02](#) [CAPTIVE JACK SCREW](#) [73542-02](#) [CAPTIVE SHORT THUMBSCREW](#) [745564-1](#) [751-00001](#) [7680](#) [809704-1](#) [8700](#)
[8860220](#) [9521](#) [992763-3](#) [1-18024-0](#) [A168P1](#) [1-24921-1](#) [125416-1](#) [1301810148](#) [1301810313](#) [1301810400](#) [1301830031](#) [1-306131-6](#)
[1301810131](#) [1301830042](#) [1393160-3](#) [1458](#) [1-59781-3](#) [18029-4](#) [NBX-10953](#) [NUT-16-3P-HEX-NICKEL](#) [2079764-1](#) [20993.45098](#) [21004-1](#)
[21009-4](#) [21014-5](#) [21021-2](#) [CA24037A01](#) [22987-4](#) [2-305927-7](#) [2327](#)