

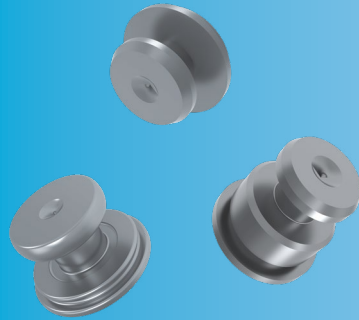

PEM® KEYHOLE® fasteners are designed for quick panel attachment and reduction of loose hardware.



**SK™**

**SELF-CLINCHING  
KEYHOLE® FASTENERS**

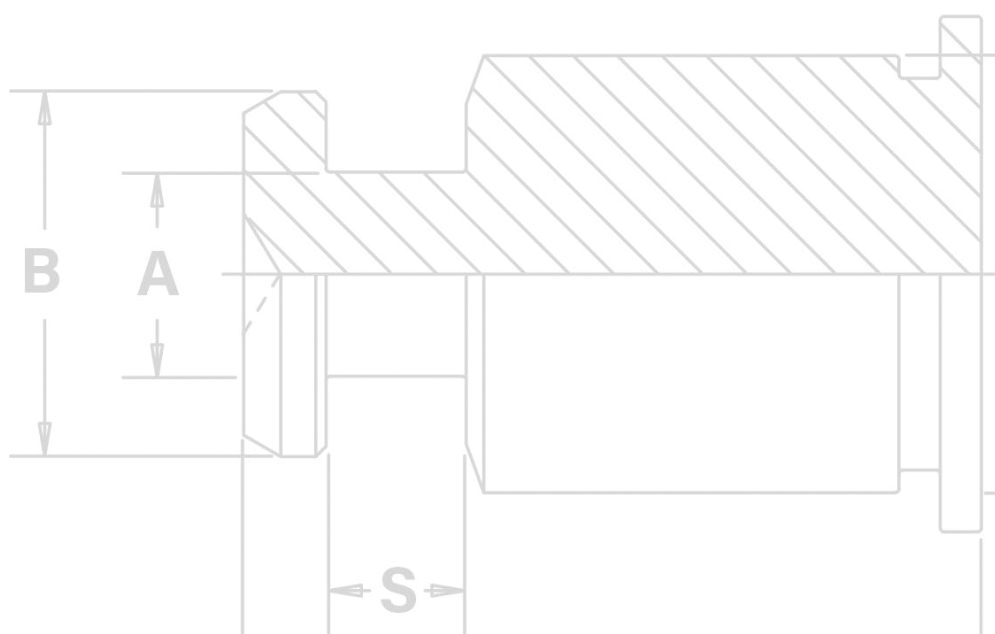

# KEYHOLE® STANDOFFS AND FASTENERS

PEM® KEYHOLE® Standoffs and sheet joining fasteners are designed so that a PC board or panel can be quickly slipped into place and then removed from an assembly by simply sliding the board sideways and lifting it off. These standoffs and fasteners can save valuable time and dramatically reduce the amount of loose hardware required.

**SKC™/SK4™/SKCF™/SK4F™/SKSF™ standoffs** can be used for spacing or mounting of replaceable components. Typically, several standoffs are used with one standard PEM® threaded standoff which accepts a screw to secure the board or component against any unwanted movement.

- Allow detachable spacing of two sheets
- Clinch feature mounts fastener permanently and flush into metal sheet
- Unique barrel design allows for quick attachment and detachment
- Makes horizontal or vertical component mounting possible
- SK4™ and SK4F™ standoffs are available for installation into stainless steel sheets

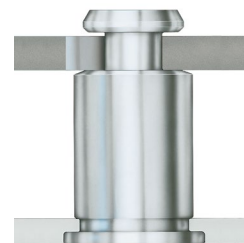

**SKC-F™/SK4-F™/SKS-R™/HSKC-R™/HSK4-R™/HSKS-R™/TSKC-R™/TSK4-R™/TSKS-R™ fasteners** are designed so that two sheets can be quickly joined flat against each other. Typically, several fasteners are used with one standard PEM® threaded F™ flush nut ([PEM® Bulletin F](#)) which accepts a screw to secure the sheets against any unwanted movement.

- Allow detachable spacing of two sheets
- Clinch feature mounts fastener permanently and flush or sub-flush into metal sheet
- Unique barrel design allows for quick "panel-on-panel" attachment and detachment
- Can be clinched into blind hole where concealed head is required
- Makes horizontal or vertical component mounting possible
- SK4-R™, HSK4-R™, TSK4-R™, SK4-F™, SK4F-F™ and TSK4F-F™ fasteners are available for installation into stainless steel sheets
- SKS-R™, SKC-R™, SK4-R™, TSKS-R™, HSKS-R™, TSKC-R™, TSK4-R™, HSKC-R™ and HSK4-R™ fasteners are designed to provide high side-load in vertical component mounting applications and are available for various top sheet thicknesses and hole sizes



SKC-F™/SK4-F™ Fasteners



SKS-R™/HSKC-R™/HSK4-R™/  
HSKS-R™/TSKC-R™/TSK4-R™/  
TSKS-R™ Fasteners



SKC™/SK4™/SKCF™/SK4F™/  
SKSF™ standoffs



SKC-F™/SK4-F™/SKS-R™/HSKC-R™/  
HSK4-R™/HSKS-R™/TSKC-R™/  
TSK4-R™/TSKS-R™ fasteners



Drawings and models  
are available at  
[www.pemnet.com](http://www.pemnet.com)

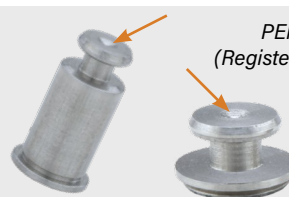

PEM® Dimple  
(Registered Trademark)

## SKC™/SK4™ STANDOFF DIMENSIONAL DATA

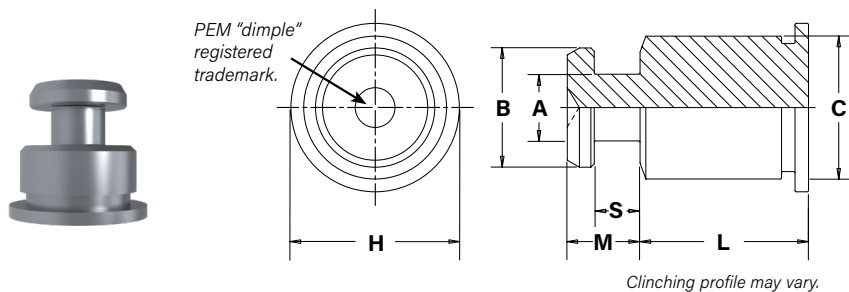

### PART NUMBER DESIGNATION

<b>SK</b>	<b>C</b>	<b>-</b>	<b>6</b>	<b>060</b>	<b>-</b>	<b>12</b>
<b>SK</b>	<b>4</b>	<b>-</b>	<b>6</b>	<b>060</b>	<b>-</b>	<b>12</b>
↓	↓		↓	↓		↓
Type	Material Code		Body Size Code	Sheet Thickness Code		Length Code

All dimensions are in inches.

UNIFIED	Type		Body Size - Sheet Code	Length "L" ± .005 (Length Code in 32nds of an inch)												A	B	C	S	M	H	
	300 Series Stainless Steel	400 Series Stainless Steel		.063	.125	.188	.250	.312	.375	.437	.500	.562	.625	.750	.875	1.00	± .003	± .003	Max.	± .003	Max.	Nom.
	SKC	SK4		6060	2	4	6	8	10	12	14	16	18	20	24	28	32	.099	.177	.212	.068	.108

All dimensions are in millimeters.

METRIC	Type		Body Size - Sheet Code	Length "L" ± 0.13 (Length Code in millimeters)												A	B	C	S	M	H	
	300 Series Stainless Steel (1)	400 Series Stainless Steel (2)		.063	.125	.188	.250	.312	.375	.437	.500	.562	.625	.750	.875	1.00	± 0.08	± 0.08	Max.	± 0.08	Max.	Nom.
	SKC	SK4		61.5	2	4	6	8	10	12	14	16	18	20	22	25	2.51	4.5	5.39	1.73	2.75	6.35

## SKCF™/SK4F™/SKSF™ STANDOFF DIMENSIONAL DATA

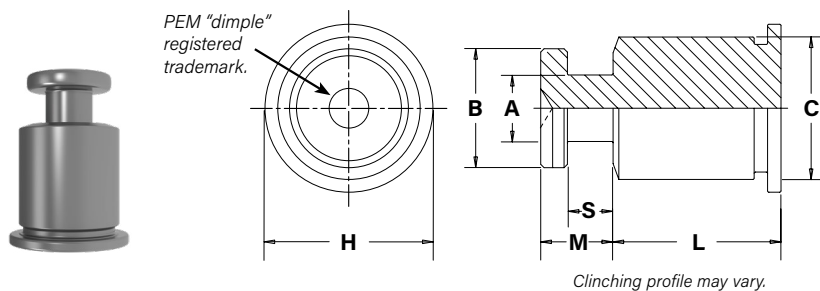

### PART NUMBER DESIGNATION

<b>SK</b>	<b>C</b>	<b>F</b>	<b>-</b>	<b>6</b>	<b>060</b>	<b>-</b>	<b>8</b>
<b>SK</b>	<b>4</b>	<b>F</b>	<b>-</b>	<b>6</b>	<b>060</b>	<b>-</b>	<b>8</b>
<b>SK</b>	<b>S</b>	<b>F</b>	<b>-</b>	<b>6</b>	<b>060</b>	<b>-</b>	<b>8</b>
↓	↓	↓		↓	↓		↓
Type	Material Code	Manufacturing Code		Body Size Code	Sheet Thickness Code		Length Code

All dimensions are in inches.

UNIFIED	Type			Body Size Sheet Code	Length "L" ± .005 (Length Code in 32nds of an inch)					A	B	C	S	M	H
	300 Series Stainless Steel	400 Series Stainless Steel	Hardened Steel		.125	.188	.250	.312	.375	± .003	± .003	Max.	± .003	Max.	Nom.
	SKCF	SK4F	SKSF		6060	4	6	8	10	12	.099	.177	.212	.068	.108

All dimensions are in millimeters.

METRIC	Type			Body Size Sheet Code	Length "L" ± 0.13 (Length Code in millimeters)					A	B	C	S	M	H
	300 Series Stainless Steel	400 Series Stainless Steel	Hardened Steel		.063	.125	.188	.250	.312	± 0.08	± 0.08	Max.	± 0.08	Max.	Nom.
	SKCF	SK4F	SKSF		61.5	4	6	8	10	2.51	4.5	5.39	1.73	2.75	6.35



# KEYHOLE® STANDOFFS AND FASTENERS

## SKC-F™/SK4-F™ FASTENER DIMENSIONAL DATA

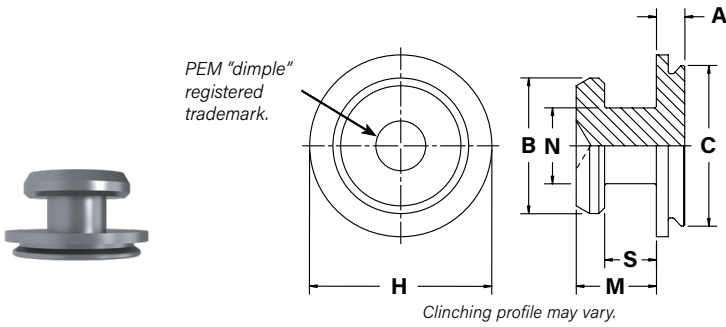

### PART NUMBER DESIGNATION

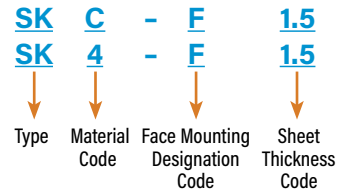

All dimensions are in inches.

UNIFIED	Type			Face Mounting Designation Code	Top Sheet Thickness Code	A Max.	B ± .003	C Max.	H Nom.	M Max.	N ± .003	S ±.003
	300 Series Stainless Steel	400 Series Stainless Steel										
	SKC	SK4	F									

All dimensions are in millimeters.

METRIC	Type			Face Mounting Designation Code	Top Sheet Thickness Code	A Max.	B ± 0.08	C Max.	H Nom.	M Max.	N ± 0.08	S ±0.08
	300 Series Stainless Steel	400 Series Stainless Steel										
	SKC	SK4	F									

## SKCF-F™/SK4F-F™/SKSF-F™/ TSKCF-F™/TSK4-F™/TSKSF-F™ FASTENER DIMENSIONAL DATA

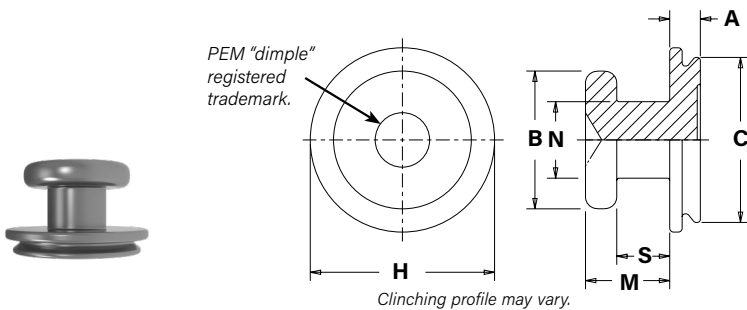

### PART NUMBER DESIGNATION

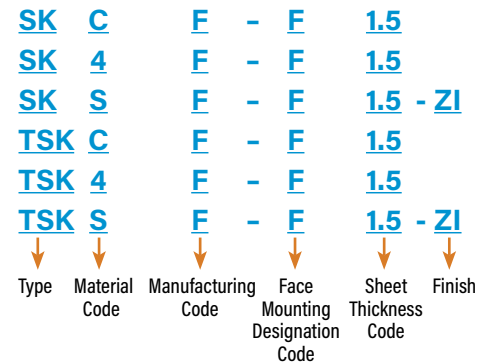

TSK for .032" / 0.8mm thick panels

All dimensions are in inches.

UNIFIED	Type			Face Mounting Designation Code	Top Sheet Thickness Code	A Max.	B ± .003	C Max.	H Nom.	M Max.	N ± .003	S ±.003
	300 Series Stainless Steel	400 Series Stainless Steel	Hardened Steel									
	SKCF	SK4F	SKSF									
TSKCF	TSK4F	TSKSF	F	1.5	.032	.177	.212	.237	.108	.099	.068	

All dimensions are in millimeters.

METRIC	Type			Face Mounting Designation Code	Top Sheet Thickness Code	A Max.	B ± 0.08	C Max.	H Nom.	M Max.	N ± 0.08	S ±0.08
	300 Series Stainless Steel	400 Series Stainless Steel	Hardened Steel									
	SKCF	SK4F	SKSF									
TSKCF	TSK4F	TSKSF	F	1.5	0.8	4.5	5.39	6.02	2.75	2.5	1.73	



# KEYHOLE® STANDOFFS AND FASTENERS

## SKS-R™, SKC-R™ AND SK4-R™ FASTENER DIMENSIONAL DATA

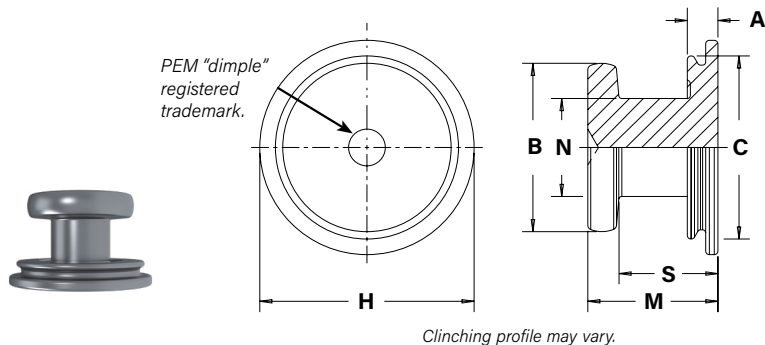

### PART NUMBER DESIGNATION

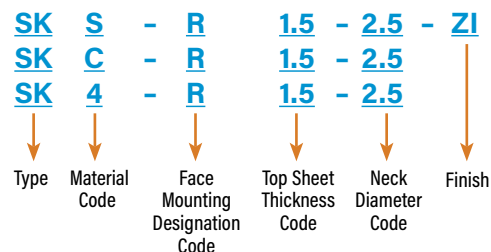

All dimensions are in inches.

UNIFIED	Type	Face Mounting Designation Code	Top Sheet Thickness Code	Neck Diameter Code	A (Shank) Max.	B ±.003	C Max.	H Nom.	M Max.	N ±.003	S +.003 -0.08
	Hardened Steel										
UNIFIED	SKS	R	1.5	2.5	.039	.177	.212	.236	.148	.099	.107
				3.2		.217	.235	.276		.126	
				4.0		.256	.275	.307		.157	
	SKS	R	2.0	2.5	.039	.177	.212	.236	.167	.099	.127
				3.2		.217	.235	.276		.126	
				4.0		.256	.275	.307		.157	
	SKS	R	2.5	2.5	.039	.177	.212	.236	.187	.099	.147
				3.2		.217	.235	.276		.126	
				4.0		.256	.275	.307		.157	

All dimensions are in millimeters.

METRIC	Type	Face Mounting Designation Code	Top Sheet Thickness Code	Neck Diameter Code	A (Shank) Max.	B ±0.08	C Max.	H Nom.	M Max.	N ±0.08	S +0.08 -0.21
	Hardened Steel										
METRIC	SKS	R	1.5	2.5	1	4.5	5.39	6	3.75	2.5	2.73
				3.2		5.5	5.98	7		3.2	
				4.0		6.5	6.98	7.8		4	
	SKS	R	2.0	2.5	1	4.5	5.39	6	4.25	2.5	3.23
				3.2		5.5	5.98	7		3.2	
				4.0		6.5	6.98	7.8		4	
	SKS	R	2.5	2.5	1	4.5	5.39	6	4.75	2.5	3.73
				3.2		5.5	5.98	7		3.2	
				4.0		6.5	6.98	7.8		4	

All dimensions are in inches.

UNIFIED	Type		Face Mounting Designation Code	Top Sheet Thickness Code	Neck Diameter Code	A (Shank) Max.	B ±.003	C Max.	H Nom.	M Max.	N ±.003	S ±.003
	300 Series Stainless Steel	400 Series Stainless Steel										
UNIFIED	SKC	SK4	R	1.5	2.5	.039	.177	.236	.276	.148	.099	.107
					3.2		.217	.276	.315		.126	
					4.0		.256	.315	.354		.157	
	SKC	SK4	R	2.0	2.5	.039	.177	.236	.276	.167	.099	.127
					3.2		.217	.276	.315		.126	
					4.0		.256	.315	.354		.157	
	SKC	SK4	R	2.5	2.5	.039	.177	.236	.276	.187	.099	.147
					3.2		.217	.276	.315		.126	
					4.0		.256	.315	.354		.157	

All dimensions are in millimeters.

METRIC	Type		Face Mounting Designation Code	Top Sheet Thickness Code	Neck Diameter Code	A (Shank) Max.	B ±0.08	C Max.	H Nom.	M Max.	N ±0.08	S ±0.08
	300 Series Stainless Steel	400 Series Stainless Steel										
METRIC	SKC	SK4	R	1.5	2.5	1	4.5	6	7	3.75	2.5	2.73
					3.2		5.5	7	8		3.2	
					4.0		6.5	8	9		4	
	SKC	SK4	R	2.0	2.5	1	4.5	6	7	4.25	2.5	3.23
					3.2		5.5	7	8		3.2	
					4.0		6.5	8	9		4	
	SKC	SK4	R	2.5	2.5	1	4.5	6	7	4.75	2.5	3.73
					3.2		5.5	7	8		3.2	
					4.0		6.5	8	9		4	



# KEYHOLE® STANDOFFS AND FASTENERS

## TSKS-R™, TSKC-R™, TSK4-R™, HSKS-R™, HSKC-R™ AND HSK4-R™ FASTENER DIMENSIONAL DATA

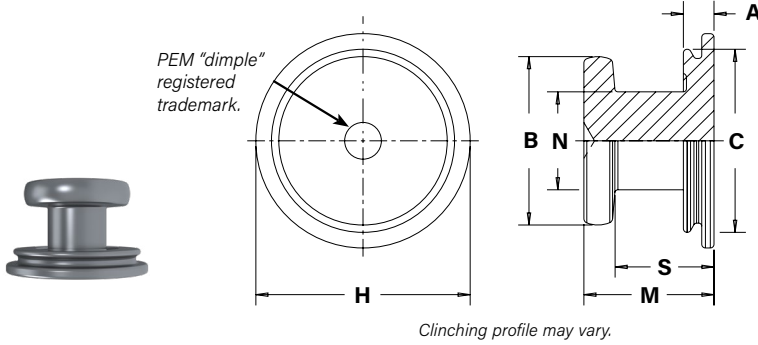

### PART NUMBER DESIGNATION

**TSK** **C** - **R**      **1.5** - **2.5**  
**TSK** **4** - **R**      **1.5** - **2.5**  
**TSK** **S** - **R**      **1.5** - **2.5** - **ZI**  
**HSK** **C** - **R**      **1.5** - **2.5**  
**HSK** **4** - **R**      **1.5** - **2.5**  
**HSK** **S** - **R**      **1.5** - **2.5** - **ZI**

↓      ↓      ↓      ↓      ↓      ↓  
 Type   Material   Face   Top Sheet   Neck   Finish  
       Code   Mounting   Thickness   Diameter   Code  
       Code   Designation   Code   Code   Code

TSK for .032" / 0.8mm thick panels  
 HSK for .047" / 1.2mm thick panels

All dimensions are in inches.

UNIFIED	Type			Face Mounting Designation Code	Top Sheet Thickness Code	Neck Diameter Code	A (Shank) Max.	B ±.003	C Max.	H Nom.	M Max.	N ±.003	S ±.003										
	Hardened Steel	300 Series Stainless Steel	400 Series Stainless Steel																				
	TSKS	TSKC	TSK4											R	1.5	2.5	.032	.177	.236	.276	.140	.099	.100
	TSKS	TSKC	TSK4											R	2.0	2.5	.032	.177	.236	.276	.159	.099	.119
TSKS	TSKC	TSK4	R	2.5	2.5	.032	.177	.236	.276	.179	.099	.139											

All dimensions are in millimeters.

METRIC	Type			Face Mounting Designation Code	Top Sheet Thickness Code	Neck Diameter Code	A (Shank) Max.	B ±0.08	C Max.	H Nom.	M Max.	N ±0.08	S ±0.08										
	Hardened Steel	300 Series Stainless Steel	400 Series Stainless Steel																				
	TSKS	TSKC	TSK4											R	1.5	2.5	0.8	4.5	6	7	3.55	2.5	2.53
	TSKS	TSKC	TSK4											R	2.0	2.5	0.8	4.5	6	7	4.05	2.5	3.03
TSKS	TSKC	TSK4	R	2.5	2.5	0.8	4.5	6	7	4.55	2.5	3.53											

All dimensions are in inches.

UNIFIED	Type			Face Mounting Designation Code	Top Sheet Thickness Code	Neck Diameter Code	A (Shank) Max.	B ±.003	C Max.	H Nom.	M Max.	N ±.003	S ±.003										
	Hardened Steel	300 Series Stainless Steel	400 Series Stainless Steel																				
	HSKS	HSKC	HSK4											R	1.5	2.5	.047	.177	.236	.276	.156	.099	.115
4.0				.256	.315	.354	.157																
HSKS	HSKC	HSK4	R	2.0	2.5	.047	.177	.236	.276	.175	.099	.135											
													3.2	.217	.276	.315	.126						
													4.0	.256	.315	.354	.157						
HSKS	HSKC	HSK4	R	2.5	2.5	.047	.177	.236	.276	.198	.099	.155											
													3.2	.217	.276	.315	.126						
													4.0	.256	.315	.354	.157						

All dimensions are in millimeters.

METRIC	Type			Face Mounting Designation Code	Top Sheet Thickness Code	Neck Diameter Code	A (Shank) Max.	B ±0.08	C Max.	H Nom.	M Max.	N ±0.08	S ±0.08										
	Hardened Steel	300 Series Stainless Steel	400 Series Stainless Steel																				
	HSKS	HSKC	HSK4											R	1.5	2.5	1.2	4.5	6	7	3.95	2.5	2.93
4.0				6.5	8	9	4																
HSKS	HSKC	HSK4	R	2.0	2.5	1.2	4.5	6	7	4.45	2.5	3.43											
													3.2	5.5	7	8	3.2						
													4.0	6.5	8	9	4						
HSKS	HSKC	HSK4	R	2.5	2.5	1.2	4.5	6	7	4.95	2.5	3.93											
													3.2	5.5	7	8	3.2						
													4.0	6.5	8	9	4						
HSKS	-	-	R	1.2	4.0	1.2	7	8	9.5	3.9	4	2.6											





# KEYHOLE® STANDOFFS AND FASTENERS

## APPLICATION DATA

### SKC™/SK4™/ SKCF™/SK4F™/SKSF™ STANDOFFS

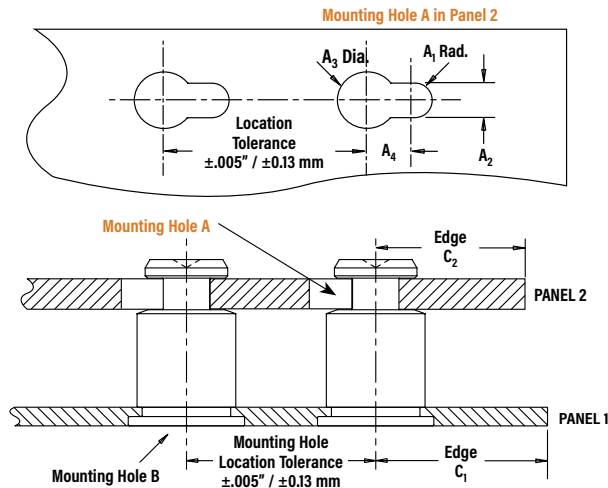

### SKC-F™/SK4-F™/ SKCF-F™/SK4-F™/SKSF-F™/ TSKCF-F™/TSK4-F™/TSKSF-F™ FASTENERS

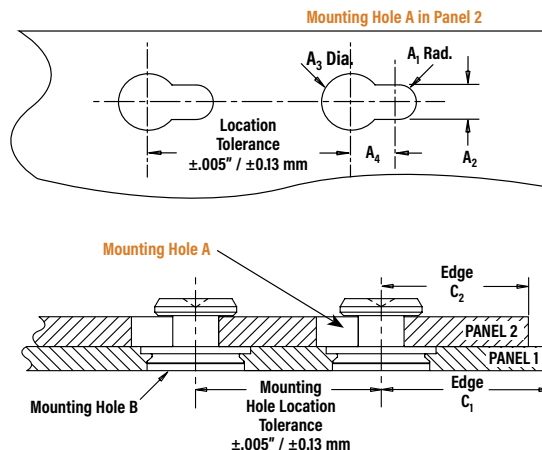

All dimensions are in inches.

UNIFIED	Panel 1					Panel 2						
	Type	Bottom Mounting Hole B +.003 -.000	Sheet Hardness Max. <sup>(1)</sup>	Min. Sheet Thickness	Edge Distance C <sub>1</sub> Min. <sup>(4)</sup>	Top Mounting Hole A				Material	Thickness Range	Edge Distance C <sub>2</sub> Min. <sup>(4)</sup>
						A <sub>1</sub> Nom.	A <sub>2</sub> ±.003	A <sub>3</sub> ±.003	A <sub>4</sub> Min.			
SKC-6060	.213	HRB 70 / HB 125	.040	.260	.059	.118	.197	.148	ANY	.057 -.064	.160	
SK4-6060	.213	HRB 88 / HB 183	.040	.260	.059	.118	.197	.148	ANY	.057 -.064	.160	
SKCF-6060	.213	HRB 70 / HB 125	.040	.260	.059	.118	.197	.148	ANY	.057 -.064	.160	
SK4F-6060	.213	HRB 88 / HB 183	.040	.260	.059	.118	.197	.148	ANY	.057 -.064	.160	
SKSF-6060	.213	HRB 80 / HB 150	.040	.260	.059	.118	.197	.148	ANY	.057 -.064	.160	
SKC-F1.5	.213	HRB 70 / HB 125	.040 <sup>(2)</sup>	.150	.059	.118	.197	.148	ANY	.057 -.064	.160	
SK4-F1.5	.213	HRB 88 / HB 183	.040 <sup>(2)</sup>	.150	.059	.118	.197	.148	ANY	.057 -.064	.160	
SKCF-F1.5	.213	HRB 70 / HB 125	.040 <sup>(2)</sup>	.150	.059	.118	.197	.148	ANY	.057 -.064	.160	
SK4F-F1.5	.213	HRB 88 / HB 183	.040 <sup>(2)</sup>	.150	.059	.118	.197	.148	ANY	.057 -.064	.160	
SKSF-F1.5	.213	HRB 80 / HB 150	.040 <sup>(2)</sup>	.150	.059	.118	.197	.148	ANY	.057 -.064	.160	
TSKCF-F1.5	.213	HRB 70 / HB 125	.032 <sup>(3)</sup>	.150	.059	.118	.197	.148	ANY	.057 -.064	.160	
TSK4F-F1.5	.213	HRB 88 / HB 183	.032 <sup>(3)</sup>	.150	.059	.118	.197	.148	ANY	.057 -.064	.160	
TSKSF-F1.5	.213	HRB 80 / HB 150	.032 <sup>(3)</sup>	.150	.059	.118	.197	.148	ANY	.057 -.064	.160	

All dimensions are in millimeters.

METRIC	Panel 1					Panel 2						
	Type	Bottom Mounting Hole B +0.08	Sheet Hardness Max. <sup>(1)</sup>	Min. Sheet Thickness	Edge Distance C <sub>1</sub> Min. <sup>(4)</sup>	Top Mounting Hole A				Material	Thickness Range	Edge Distance C <sub>2</sub> Min. <sup>(4)</sup>
						A <sub>1</sub> Nom.	A <sub>2</sub> ±0.08	A <sub>3</sub> ±0.08	A <sub>4</sub> Min.			
SKC-61.5	5.41	HRB 70 / HB 125	1	6.6	1.5	3	5	3.75	ANY	1.45 - 1.62	4.1	
SK4-61.5	5.41	HRB 88 / HB 183	1	6.6	1.5	3	5	3.75	ANY	1.45 - 1.62	4.1	
SKCF-61.5	5.41	HRB 70 / HB 125	1	6.6	1.5	3	5	3.75	ANY	1.45 - 1.62	4.1	
SK4F-61.5	5.41	HRB 88 / HB 183	1	6.6	1.5	3	5	3.75	ANY	1.45 - 1.62	4.1	
SKSF-61.5	5.41	HRB 80 / HB 150	1	6.6	1.5	3	5	3.75	ANY	1.45 - 1.62	4.1	
SKC-F1.5	5.41	HRB 70 / HB 125	1 <sup>(2)</sup>	3.8	1.5	3	5	3.75	ANY	1.45 - 1.62	4.1	
SK4-F1.5	5.41	HRB 88 / HB 183	1 <sup>(2)</sup>	3.8	1.5	3	5	3.75	ANY	1.45 - 1.62	4.1	
SKCF-F1.5	5.41	HRB 70 / HB 125	1 <sup>(2)</sup>	3.8	1.5	3	5	3.75	ANY	1.45 - 1.62	4.1	
SK4F-F1.5	5.41	HRB 88 / HB 183	1 <sup>(2)</sup>	3.8	1.5	3	5	3.75	ANY	1.45 - 1.62	4.1	
SKSF-F1.5	5.41	HRB 80 / HB 150	1 <sup>(2)</sup>	3.8	1.5	3	5	3.75	ANY	1.45 - 1.62	4.1	
TSKCF-F1.5	5.41	HRB 70 / HB 125	0.8 <sup>(3)</sup>	3.8	1.5	3	5	3.75	ANY	1.45 - 1.62	4.1	
TSK4F-F1.5	5.41	HRB 88 / HB 183	0.8 <sup>(3)</sup>	3.8	1.5	3	5	3.75	ANY	1.45 - 1.62	4.1	
TSKSF-F1.5	5.41	HRB 80 / HB 150	0.8 <sup>(3)</sup>	3.8	1.5	3	5	3.75	ANY	1.45 - 1.62	4.1	

(1) HRB - Hardness Rockwell "B" Scale. HB - Hardness Brinell.

(2) SKC-F™/SK4-F™/ SKCF-F™/SK4F-F™/SKSF-F™ fasteners may also be installed into a .043"/1.1mm minimum depth blind milled hole in a .062"/1.6mm minimum sheet thickness.

(3) TSKCF-F™/TSK4F-F™/TSKSF-F™ fasteners may also be installed into a .035"/0.9mm minimum depth blind milled hole in a .055"/1.4mm minimum sheet thickness.

(4) For more information on proximity to bends and distance to other clinch hardware, see [PEM® Tech Sheet C/L To Edge](#).



# KEYHOLE® STANDOFFS AND FASTENERS

## APPLICATION DATA - SKS-R™/SKC-R™/SK4-R™/ TSKS-R™/HSKS-R™/ TSKC-R™/TSK4-R™/HSKC-R™/HSK4-R™ FASTENERS

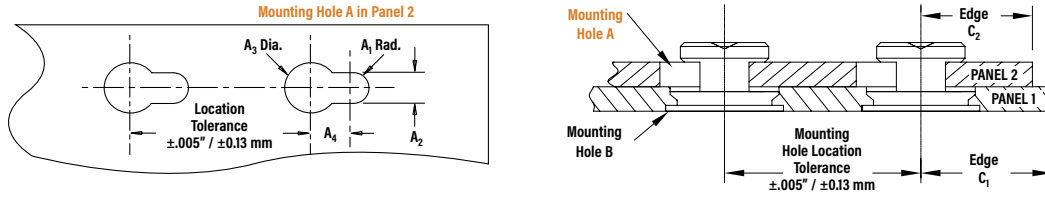

All dimensions are in inches.

Type	PANEL 1				PANEL 2						
	Bottom Mounting Hole B +.003-.000	Sheet Hardness Max. (1)	Thickness Range	Edge Distance C <sub>1</sub> Min. (2)	Top Mounting Hole A				Material	Thickness Max.	Edge Distance C <sub>2</sub> Min. (2)
					A <sub>1</sub> Nom.	A <sub>2</sub> ±.003	A <sub>3</sub> ±.003	A <sub>4</sub> Min.			
SKS-R1.5-2.5-ZI	.213	HRB 80 / HB 150	.040 - .047	.236	.059	.118	.197	.148	ANY	.060	.160
SKS-R1.5-3.2-ZI	.236	HRB 80 / HB 150	.040 - .047	.236	.073	.146	.236	.181	ANY	.060	.201
SKS-R1.5-4.0-ZI	.276	HRB 80 / HB 150	.040 - .047	.236	.089	.177	.276	.217	ANY	.060	.240
SKS-R2.0-2.5-ZI	.213	HRB 80 / HB 150	.040 - .047	.236	.059	.118	.197	.148	ANY	.080	.160
SKS-R2.0-3.2-ZI	.236	HRB 80 / HB 150	.040 - .047	.236	.073	.146	.236	.181	ANY	.080	.201
SKS-R2.0-4.0-ZI	.276	HRB 80 / HB 150	.040 - .047	.236	.089	.177	.276	.217	ANY	.080	.240
SKS-R2.5-2.5-ZI	.213	HRB 80 / HB 150	.040 - .047	.236	.059	.118	.197	.148	ANY	.100	.160
SKS-R2.5-3.2-ZI	.236	HRB 80 / HB 150	.040 - .047	.236	.073	.146	.236	.181	ANY	.100	.201
SKS-R2.5-4.0-ZI	.276	HRB 80 / HB 150	.040 - .047	.236	.089	.177	.276	.217	ANY	.100	.240
SKC-R1.5-2.5	.237	HRB 70 / HB 125	.040 - .047	.276	.059	.118	.197	.148	ANY	.060	.160
SKC-R1.5-3.2	.277	HRB 70 / HB 125	.040 - .047	.295	.073	.146	.236	.181	ANY	.060	.201
SKC-R1.5-4.0	.316	HRB 70 / HB 125	.040 - .047	.315	.089	.177	.276	.217	ANY	.060	.240
SKC-R2.0-2.5	.237	HRB 70 / HB 125	.040 - .047	.276	.059	.118	.197	.148	ANY	.080	.160
SKC-R2.0-3.2	.277	HRB 70 / HB 125	.040 - .047	.295	.073	.146	.236	.181	ANY	.080	.201
SKC-R2.0-4.0	.316	HRB 70 / HB 125	.040 - .047	.315	.089	.177	.276	.217	ANY	.080	.240
SKC-R2.5-2.5	.237	HRB 70 / HB 125	.040 - .047	.276	.059	.118	.197	.148	ANY	.100	.160
SKC-R2.5-3.2	.277	HRB 70 / HB 125	.040 - .047	.295	.073	.146	.236	.181	ANY	.100	.201
SKC-R2.5-4.0	.316	HRB 70 / HB 125	.040 - .047	.315	.089	.177	.276	.217	ANY	.100	.240
SK4-R1.5-2.5	.237	HRB 88 / HB 183	.040 - .047	.276	.059	.118	.197	.148	ANY	.060	.160
SK4-R1.5-3.2	.277	HRB 88 / HB 183	.040 - .047	.295	.073	.146	.236	.181	ANY	.060	.201
SK4-R1.5-4.0	.316	HRB 88 / HB 183	.040 - .047	.315	.089	.177	.276	.217	ANY	.060	.240
SK4-R2.0-2.5	.237	HRB 88 / HB 183	.040 - .047	.276	.059	.118	.197	.148	ANY	.080	.160
SK4-R2.0-3.2	.277	HRB 88 / HB 183	.040 - .047	.295	.073	.146	.236	.181	ANY	.080	.201
SK4-R2.0-4.0	.316	HRB 88 / HB 183	.040 - .047	.315	.089	.177	.276	.217	ANY	.080	.240
SK4-R2.5-2.5	.237	HRB 88 / HB 183	.040 - .047	.276	.059	.118	.197	.148	ANY	.100	.160
SK4-R2.5-3.2	.277	HRB 88 / HB 183	.040 - .047	.295	.073	.146	.236	.181	ANY	.100	.201
SK4-R2.5-4.0	.316	HRB 88 / HB 183	.040 - .047	.315	.089	.177	.276	.217	ANY	.100	.240
TSKS-R1.5-2.5-ZI	.237	HRB 80 / HB 150	.032 - .038	.276	.059	.118	.197	.148	ANY	.060	.160
TSKS-R2.0-2.5-ZI	.237	HRB 80 / HB 150	.032 - .038	.276	.059	.118	.197	.148	ANY	.080	.160
TSKS-R2.5-2.5-ZI	.237	HRB 80 / HB 150	.032 - .038	.276	.059	.118	.197	.148	ANY	.100	.160
HSKS-R1.5-2.5-ZI	.237	HRB 80 / HB 150	.047 - .055	.276	.059	.118	.197	.148	ANY	.060	.160
HSKS-R1.5-3.2-ZI	.277	HRB 80 / HB 150	.047 - .055	.295	.073	.146	.236	.181	ANY	.060	.201
HSKS-R1.5-4.0-ZI	.316	HRB 80 / HB 150	.047 - .055	.315	.089	.177	.276	.217	ANY	.060	.240
HSKS-R2.0-2.5-ZI	.237	HRB 80 / HB 150	.047 - .055	.276	.059	.118	.197	.148	ANY	.080	.160
HSKS-R2.0-3.2-ZI	.277	HRB 80 / HB 150	.047 - .055	.295	.073	.146	.236	.181	ANY	.080	.201
HSKS-R2.0-4.0-ZI	.316	HRB 80 / HB 150	.047 - .055	.315	.089	.177	.276	.217	ANY	.080	.240
HSKS-R2.5-2.5-ZI	.237	HRB 80 / HB 150	.047 - .055	.276	.059	.118	.197	.148	ANY	.100	.160
HSKS-R2.5-3.2-ZI	.277	HRB 80 / HB 150	.047 - .055	.295	.073	.146	.236	.181	ANY	.100	.201
HSKS-R2.5-4.0-ZI	.316	HRB 80 / HB 150	.047 - .055	.315	.089	.177	.276	.217	ANY	.100	.240
TSKC-R1.5-2.5	.237	HRB 70 / HB 125	.032 - .038	.276	.059	.118	.197	.148	ANY	.060	.160
TSKC-R2.0-2.5	.237	HRB 70 / HB 125	.032 - .038	.276	.059	.118	.197	.148	ANY	.080	.160
TSKC-R2.5-2.5	.237	HRB 70 / HB 125	.032 - .038	.276	.059	.118	.197	.148	ANY	.100	.160
HSKC-R1.5-2.5	.237	HRB 70 / HB 125	.047 - .055	.276	.059	.118	.197	.148	ANY	.060	.160
HSKC-R1.5-3.2	.277	HRB 70 / HB 125	.047 - .055	.295	.073	.146	.236	.181	ANY	.060	.201
HSKC-R1.5-4.0	.316	HRB 70 / HB 125	.047 - .055	.315	.089	.177	.276	.217	ANY	.060	.240
HSKC-R2.0-2.5	.237	HRB 70 / HB 125	.047 - .055	.276	.059	.118	.197	.148	ANY	.080	.160
HSKC-R2.0-3.2	.277	HRB 70 / HB 125	.047 - .055	.295	.073	.146	.236	.181	ANY	.080	.201
HSKC-R2.0-4.0	.316	HRB 70 / HB 125	.047 - .055	.315	.089	.177	.276	.217	ANY	.080	.240
HSKC-R2.5-2.5	.237	HRB 70 / HB 125	.047 - .055	.276	.059	.118	.197	.148	ANY	.100	.160
HSKC-R2.5-3.2	.277	HRB 70 / HB 125	.047 - .055	.295	.073	.146	.236	.181	ANY	.100	.201
HSKC-R2.5-4.0	.316	HRB 70 / HB 125	.047 - .055	.315	.089	.177	.276	.217	ANY	.100	.240
TSK4-R1.5-2.5	.237	HRB 88 / HB 183	.032 - .038	.276	.059	.118	.197	.148	ANY	.060	.160
TSK4-R2.0-2.5	.237	HRB 88 / HB 183	.032 - .038	.276	.059	.118	.197	.148	ANY	.080	.160
TSK4-R2.5-2.5	.237	HRB 88 / HB 183	.032 - .038	.276	.059	.118	.197	.148	ANY	.100	.160
HSK4-R1.5-2.5	.237	HRB 88 / HB 183	.047 - .055	.276	.059	.118	.197	.148	ANY	.060	.160
HSK4-R1.5-3.2	.277	HRB 88 / HB 183	.047 - .055	.295	.073	.146	.236	.181	ANY	.060	.201
HSK4-R1.5-4.0	.316	HRB 88 / HB 183	.047 - .055	.315	.089	.177	.276	.217	ANY	.060	.240
HSK4-R2.0-2.5	.237	HRB 88 / HB 183	.047 - .055	.276	.059	.118	.197	.148	ANY	.080	.160
HSK4-R2.0-3.2	.277	HRB 88 / HB 183	.047 - .055	.295	.073	.146	.236	.181	ANY	.080	.201
HSK4-R2.0-4.0	.316	HRB 88 / HB 183	.047 - .055	.315	.089	.177	.276	.217	ANY	.080	.240
HSK4-R2.5-2.5	.237	HRB 88 / HB 183	.047 - .055	.276	.059	.118	.197	.148	ANY	.100	.160
HSK4-R2.5-3.2	.277	HRB 88 / HB 183	.047 - .055	.295	.073	.146	.236	.181	ANY	.100	.201
HSK4-R2.5-4.0	.316	HRB 88 / HB 183	.047 - .055	.315	.089	.177	.276	.217	ANY	.100	.240

(1) HRB - Hardness Rockwell "B" Scale. HB - Hardness Brinell.

(2) For more information on proximity to bends and distance to other clinch hardware, see [PEM® Tech Sheet C/L To Edge](#).





# KEYHOLE® STANDOFFS AND FASTENERS

## APPLICATION DATA - SKS-R™/SKC-R™/SK4-R™/ TSKS-R™/HSKS-R™/ TSKC-R™/TSK4-R™/HSCC-R™/HSK4-R™ FASTENERS

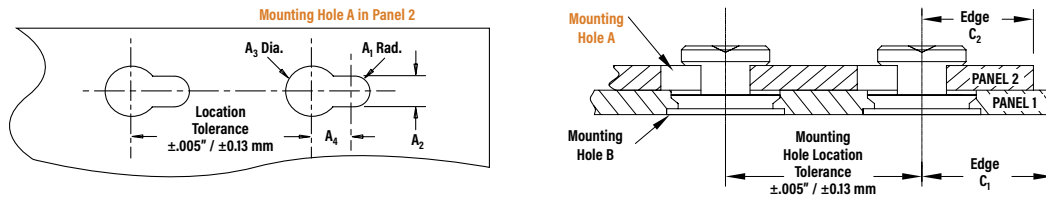

All dimensions are in millimeters.

Type	PANEL 1				PANEL 2						
	Bottom Mounting Hole B + 0.08	Sheet Hardness Max. (1)	Thickness Range	Edge Distance C <sub>1</sub> Min. (2)	Top Mounting Hole A				Material	Thickness Max.	Edge Distance C <sub>2</sub> Min. (2)
					A <sub>1</sub> Nom.	A <sub>2</sub> ±0.08	A <sub>3</sub> ± 0.08	A <sub>4</sub> Min.			
SKS-R1.5-2.5-ZI	5.41	HRB 80 / HB 150	1-1.19	6	1.5	3	5	3.75	ANY	1.54	4.1
SKS-R1.5-3.2-ZI	6	HRB 80 / HB 150	1-1.19	6	1.85	3.7	6	4.6	ANY	1.54	5.1
SKS-R1.5-4.0-ZI	7	HRB 80 / HB 150	1-1.19	6	2.25	4.5	7	5.5	ANY	1.54	6.1
SKS-R2.0-2.5-ZI	5.41	HRB 80 / HB 150	1-1.19	6	1.5	3	5	3.75	ANY	2.04	4.1
SKS-R2.0-3.2-ZI	6	HRB 80 / HB 150	1-1.19	6	1.85	3.7	6	4.6	ANY	2.04	5.1
SKS-R2.0-4.0-ZI	7	HRB 80 / HB 150	1-1.19	6	2.25	4.5	7	5.5	ANY	2.04	6.1
SKS-R2.5-2.5-ZI	5.41	HRB 80 / HB 150	1-1.19	6	1.5	3	5	3.75	ANY	2.54	4.1
SKS-R2.5-3.2-ZI	6	HRB 80 / HB 150	1-1.19	6	1.85	3.7	6	4.6	ANY	2.54	5.1
SKS-R2.5-4.0-ZI	7	HRB 80 / HB 150	1-1.19	6	2.25	4.5	7	5.5	ANY	2.54	6.1
SKC-R1.5-2.5	6.02	HRB 70 / HB 125	1-1.19	7	1.5	3	5	3.75	ANY	1.54	4.1
SKC-R1.5-3.2	7.02	HRB 70 / HB 125	1-1.19	7.5	1.85	3.7	6	4.6	ANY	1.54	5.1
SKC-R1.5-4.0	8.02	HRB 70 / HB 125	1-1.19	8	2.25	4.5	7	5.5	ANY	1.54	6.1
SKC-R2.0-2.5	6.02	HRB 70 / HB 125	1-1.19	7	1.5	3	5	3.75	ANY	2.04	4.1
SKC-R2.0-3.2	7.02	HRB 70 / HB 125	1-1.19	7.5	1.85	3.7	6	4.6	ANY	2.04	5.1
SKC-R2.0-4.0	8.02	HRB 70 / HB 125	1-1.19	8	2.25	4.5	7	5.5	ANY	2.04	6.1
SKC-R2.5-2.5	6.02	HRB 70 / HB 125	1-1.19	7	1.5	3	5	3.75	ANY	2.54	4.1
SKC-R2.5-3.2	7.02	HRB 70 / HB 125	1-1.19	7.5	1.85	3.7	6	4.6	ANY	2.54	5.1
SKC-R2.5-4.0	8.02	HRB 70 / HB 125	1-1.19	8	2.25	4.5	7	5.5	ANY	2.54	6.1
SK4-R1.5-2.5	6.02	HRB 88 / HB 183	1-1.19	7	1.5	3	5	3.75	ANY	1.54	4.1
SK4-R1.5-3.2	7.02	HRB 88 / HB 183	1-1.19	7.5	1.85	3.7	6	4.6	ANY	1.54	5.1
SK4-R1.5-4.0	8.02	HRB 88 / HB 183	1-1.19	8	2.25	4.5	7	5.5	ANY	1.54	6.1
SK4-R2.0-2.5	6.02	HRB 88 / HB 183	1-1.19	7	1.5	3	5	3.75	ANY	2.04	4.1
SK4-R2.0-3.2	7.02	HRB 88 / HB 183	1-1.19	7.5	1.85	3.7	6	4.6	ANY	2.04	5.1
SK4-R2.0-4.0	8.02	HRB 88 / HB 183	1-1.19	8	2.25	4.5	7	5.5	ANY	2.04	6.1
SK4-R2.5-2.5	6.02	HRB 88 / HB 183	1-1.19	7	1.5	3	5	3.75	ANY	2.54	4.1
SK4-R2.5-3.2	7.02	HRB 88 / HB 183	1-1.19	7.5	1.85	3.7	6	4.6	ANY	2.54	5.1
SK4-R2.5-4.0	8.02	HRB 88 / HB 183	1-1.19	8	2.25	4.5	7	5.5	ANY	2.54	6.1
TSKS-R1.5-2.5-ZI	6.02	HRB 80 / HB 150	0.8-0.95	7	1.5	3	5	3.75	ANY	1.54	4.1
TSKS-R2.0-2.5-ZI	6.02	HRB 80 / HB 150	0.8-0.95	7	1.5	3	5	3.75	ANY	2.04	4.1
TSKS-R2.5-2.5-ZI	6.02	HRB 80 / HB 150	0.8-0.95	7	1.5	3	5	3.75	ANY	2.54	4.1
HSKS-R1.5-2.5-ZI	6.02	HRB 80 / HB 150	1.2-1.39	7	1.5	3	5	3.75	ANY	1.54	4.1
HSKS-R1.5-3.2-ZI	7.02	HRB 80 / HB 150	1.2-1.39	7.5	1.85	3.7	6	4.6	ANY	1.54	5.1
HSKS-R1.5-4.0-ZI	8.02	HRB 80 / HB 150	1.2-1.39	8	2.25	4.5	7	5.5	ANY	1.54	6.1
HSKS-R2.0-2.5-ZI	6.02	HRB 80 / HB 150	1.2-1.39	7	1.5	3	5	3.75	ANY	2.04	4.1
HSKS-R2.0-3.2-ZI	7.02	HRB 80 / HB 150	1.2-1.39	7.5	1.85	3.7	6	4.6	ANY	2.04	5.1
HSKS-R2.0-4.0-ZI	8.02	HRB 80 / HB 150	1.2-1.39	8	2.25	4.5	7	5.5	ANY	2.04	6.1
HSKS-R2.5-2.5-ZI	6.02	HRB 80 / HB 150	1.2-1.39	7	1.5	3	5	3.75	ANY	2.54	4.1
HSKS-R2.5-3.2-ZI	7.02	HRB 80 / HB 150	1.2-1.39	7.5	1.85	3.7	6	4.6	ANY	2.54	5.1
HSKS-R2.5-4.0-ZI	8.02	HRB 80 / HB 150	1.2-1.39	8	2.25	4.5	7	5.5	ANY	2.54	6.1
HSKC-R1.2-4.0-ZI	8.02	HRB 80 / HB 150	1.2-1.39	8	2.25	4.5	7.5	5.75	ANY	1.21	6.6
TSKC-R1.5-2.5	6.02	HRB 70 / HB 125	0.8-0.95	7	1.5	3	5	3.75	ANY	1.54	4.1
TSKC-R2.0-2.5	6.02	HRB 70 / HB 125	0.8-0.95	7	1.5	3	5	3.75	ANY	2.04	4.1
TSKC-R2.5-2.5	6.02	HRB 70 / HB 125	0.8-0.95	7	1.5	3	5	3.75	ANY	2.54	4.1
HSKC-R1.5-2.5	6.02	HRB 70 / HB 125	1.2-1.39	7	1.5	3	5	3.75	ANY	1.54	4.1
HSKC-R1.5-3.2	7.02	HRB 70 / HB 125	1.2-1.39	7.5	1.85	3.7	6	4.6	ANY	1.54	5.1
HSKC-R1.5-4.0	8.02	HRB 70 / HB 125	1.2-1.39	8	2.25	4.5	7	5.5	ANY	1.54	6.1
HSKC-R2.0-2.5	6.02	HRB 70 / HB 125	1.2-1.39	7	1.5	3	5	3.75	ANY	2.04	4.1
HSKC-R2.0-3.2	7.02	HRB 70 / HB 125	1.2-1.39	7.5	1.85	3.7	6	4.6	ANY	2.04	5.1
HSKC-R2.0-4.0	8.02	HRB 70 / HB 125	1.2-1.39	8	2.25	4.5	7	5.5	ANY	2.04	6.1
HSKC-R2.5-2.5	6.02	HRB 70 / HB 125	1.2-1.39	7	1.5	3	5	3.75	ANY	2.54	4.1
HSKC-R2.5-3.2	7.02	HRB 70 / HB 125	1.2-1.39	7.5	1.85	3.7	6	4.6	ANY	2.54	5.1
HSKC-R2.5-4.0	8.02	HRB 70 / HB 125	1.2-1.39	8	2.25	4.5	7	5.5	ANY	2.54	6.1
TSK4-R1.5-2.5	6.02	HRB 88 / HB 183	0.8-0.95	7	1.5	3	5	3.75	ANY	1.54	4.1
TSK4-R2.0-2.5	6.02	HRB 88 / HB 183	0.8-0.95	7	1.5	3	5	3.75	ANY	2.04	4.1
TSK4-R2.5-2.5	6.02	HRB 88 / HB 183	0.8-0.95	7	1.5	3	5	3.75	ANY	2.54	4.1
HSK4-R1.5-2.5	6.02	HRB 88 / HB 183	1.2-1.39	7	1.5	3	5	3.75	ANY	1.54	4.1
HSK4-R1.5-3.2	7.02	HRB 88 / HB 183	1.2-1.39	7.5	1.85	3.7	6	4.6	ANY	1.54	5.1
HSK4-R1.5-4.0	8.02	HRB 88 / HB 183	1.2-1.39	8	2.25	4.5	7	5.5	ANY	1.54	6.1
HSK4-R2.0-2.5	6.02	HRB 88 / HB 183	1.2-1.39	7	1.5	3	5	3.75	ANY	2.04	4.1
HSK4-R2.0-3.2	7.02	HRB 88 / HB 183	1.2-1.39	7.5	1.85	3.7	6	4.6	ANY	2.04	5.1
HSK4-R2.0-4.0	8.02	HRB 88 / HB 183	1.2-1.39	8	2.25	4.5	7	5.5	ANY	2.04	6.1
HSK4-R2.5-2.5	6.02	HRB 88 / HB 183	1.2-1.39	7	1.5	3	5	3.75	ANY	2.54	4.1
HSK4-R2.5-3.2	7.02	HRB 88 / HB 183	1.2-1.39	7.5	1.85	3.7	6	4.6	ANY	2.54	5.1
HSK4-R2.5-4.0	8.02	HRB 88 / HB 183	1.2-1.39	8	2.25	4.5	7	5.5	ANY	2.54	6.1

(1) HRB - Hardness Rockwell "B" Scale. HB - Hardness Brinell.

(2) For more information on proximity to bends and distance to other clinch hardware, see [PEM® Tech Sheet C/L To Edge](#).



## MATERIAL AND FINISH SPECIFICATIONS

Type	Fastener Materials			Standard Finishes		For Use in Sheet Hardness <sup>(1)</sup>		
	Hardened Steel	300 Series Stainless Steel	Hardened 400 Series Stainless Steel	Passivated and/or tested per ASTM A380	Zinc Plated per ASTM B633, SC1 (5µm) Type III, Colorless <sup>(2)</sup>	HRB 88 / HB 183 or less	HRB 80 / HB150 or less	HRB 70 / HB 125 or less
SKC		■		■				■
SK4			■	■		■		
SKC-F		■		■				■
SK4-F			■	■		■		
SKC-R		■		■				■
SK4-R			■	■		■		
SKS-R	■				■		■	
TSKC-R		■		■				■
TSK4-R			■	■		■		
TSKS-R	■				■		■	
HSKS-R	■				■		■	
HSKC-R		■		■				■
HSK4-R			■	■		■		
SKCF-F		■		■				■
SK4F-F			■	■		■		
SKSF-F	■				■		■	
TSKCF-F		■		■				■
TSK4F-F			■	■		■		
TSKSF-F	■				■		■	
SKCF		■		■				■
SK4F			■	■		■		
SKSF	■				■		■	
Part Number Code for Finishes				None	ZI			

(1) HRB - Hardness Rockwell "B" Scale. HB - Hardness Brinell.

(2) See PEM Technical Support section of our web site for related plating standards and specifications.

### A NOTE ABOUT 400 SERIES FASTENERS FOR STAINLESS STEEL PANELS

In order for self-clinching fasteners to work properly, the fastener must be harder than the sheet into which it is being installed. In the case of stainless steel panels, fasteners made from 300 Series Stainless Steel do not meet this hardness criteria. It is for this reason that 400 series fasteners (SK4 and SK4-F) are offered. However, while these 400 Series fasteners install and perform well in 300 Series stainless sheets they should not be used if the end product:

- Will be exposed to any appreciable corrosive presence.
- Requires non-magnetic fasteners.
- Will be exposed to any temperatures above 300°F (149°C)

If any of these are issues, please contact [techsupport@pemnet.com](mailto:techsupport@pemnet.com) for other options.

## INSTALLATION

### SKC™/SK4™/ SKCF™/SK4F™/SKSF™ STANDOFFS

1. Prepare properly sized mounting hole in Panel 1.
2. Place the fastener through (punched side of) the mounting hole and into anvil as shown in figure 1.
3. With installation punch and anvil surfaces parallel, apply only enough squeezing force to embed the head flush with the panel.

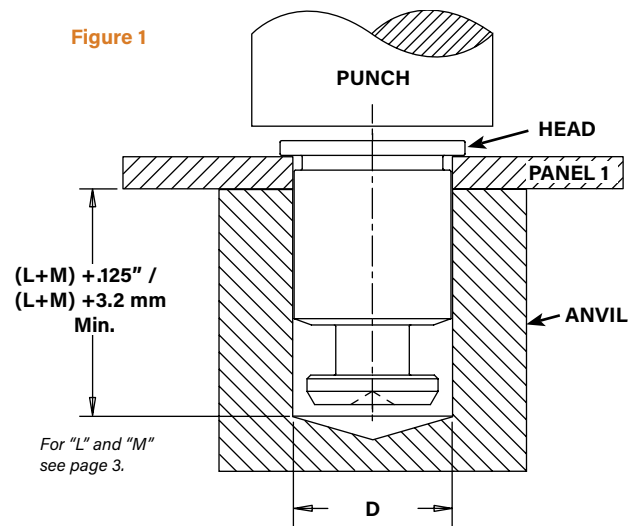

### PEMSERTER® Installation Tooling <sup>(1)</sup>

UNIFIED	Body Size Sheet Code	Anvil Dimension (in.)		Anvil Part Number	Punch Part Number
		D	+ .003 - .000		
	6060	.216		970200012300	975200048

METRIC	Body Size Sheet Code	Anvil Dimension (mm)		Anvil Part Number	Punch Part Number
		D	+0.08		
	61.5	5.49		970200012300	975200048

(1) [Click here](#) for a quote on Haeger® custom installation tooling.

### SKC-F™/SK4-F™ / SKCF-F™/SK4-F™/SKSF-F™ / TSKCF-F™/TSK4-F™/TSKSF-F™ FASTENERS

#### Through Hole Installation Procedure

1. Prepare properly sized mounting hole in Panel 1.
2. Place the fastener into anvil hole as shown in Figure 2.
3. Place the (punch side of) mounting hole over the shank of the fastener.
4. With installation punch and anvil surfaces parallel, apply only enough squeezing force until flange is flush with panel.

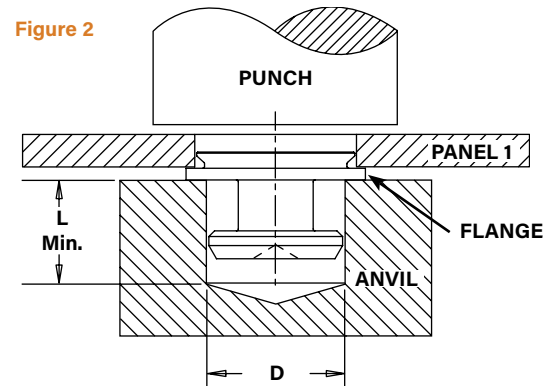

#### Blind Hole Installation Procedure

1. Mill a properly sized blind hole into Panel 1.
2. Place the fastener into anvil hole as shown in Figure 3.
3. Place the panel mounting hole over the shank of the fastener.
4. With installation punch and anvil surfaces parallel, apply only enough squeezing force to embed the flange flush with the panel.

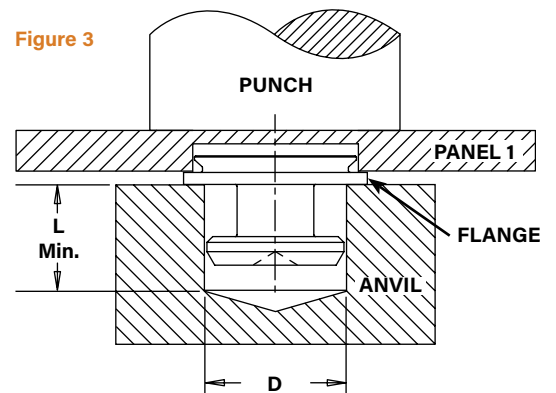

### PEMSERTER® Installation Tooling <sup>(1)</sup>

UNIFIED	Sheet Thickness Code	Anvil Dimensions (in.)		Anvil Part Number	Punch Part Number
		L Min.	D +.003 -.000		
	1.5	.233	.184	8012608	975200048

METRIC	Sheet Thickness Code	Anvil Dimensions (mm)		Anvil Part Number	Punch Part Number
		L Min.	D +0.08		
	1.5	5.95	4.67	8012608	975200048

(1) [Click here](#) for a quote on Haeger® custom installation tooling.

#### End Mill Information

Double-ended, two-flute H.S.S. center-cutting end mills are available from stock. PennEngineering does not manufacture center-cutting end mills, but we do keep a supply in stock for your convenience.



Fastener Type	Required Size End Mill	PEM Part No.
SKC-F/SK4-F	.213"	CHM-213

# KEYHOLE® STANDOFFS AND FASTENERS

## SKS-R™/SKC-R™/SK4-R™/ TSKS-R™/HKS-R™/ TSKC-R™/ TSK4-R™/HSC-R™/HSK4-R™ FASTENERS

1. Prepare properly sized mounting hole in Panel 1.
2. Place the fastener through (punch side of) the mounting hole and into anvil as shown.
3. With installation punch and anvil surfaces parallel, apply only enough squeezing force to embed the head flush with the panel.

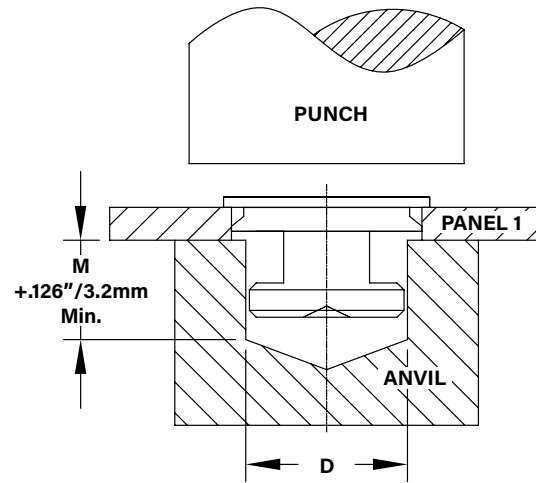

### PEMSERTER® Installation Tooling <sup>(1)</sup>

UNIFIED	Neck Diameter Code	Anvil Dimensions (in.)		Anvil Part Number	Punch Part Number
		D +.003 -.000			
	2.5	.183		8026244	975200048
	3.2	.222		8026245	
	4.0	.262		8026246	

METRIC	Neck Diameter Code	Anvil Dimensions (mm)		Anvil Part Number	Punch Part Number
		D +0.08			
	2.5	4.65		8026244	975200048
	3.2	5.65		8026245	
	4.0	6.65		8026246	

(1) [Click here](#) for a quote on Haeger® custom installation tooling.

#### INSTALLATION NOTES

- For best results we recommend using a **HAEGER®** or **PEMSERTER®** machine for installation of PEM® self-clinching fasteners. Please check our website for more information.
- Visit the Animation Library on our website to view the installation process [for select products](#).

## For Additional HAEGER® and PEMSERTER® Tooling Information / Part Numbers

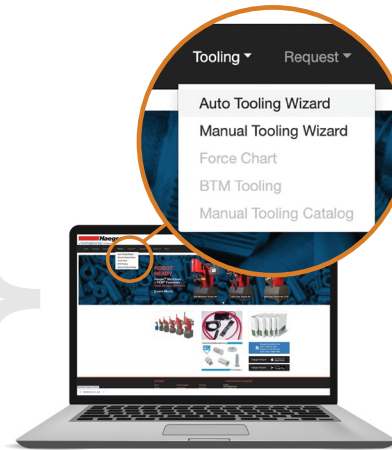

Go to [haeger.com](http://haeger.com) to access the Auto and Manual Tooling Wizards



PEMSERTER® MANUAL TOOLING CATALOG

PEMSERTER® AUTO TOOLING CATALOG

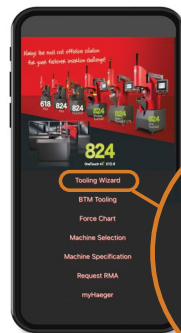

Or download the **HAEGER WIZZARD** Phone App



HAEGER® MANUAL TOOLING CATALOG

HAEGER® AUTO TOOLING CATALOG



# KEYHOLE® STANDOFFS AND FASTENERS

## PERFORMANCE DATA<sup>(1)</sup>

### SKC™/SK4™ STANDOFFS

#### Installation and pushout

Test Sheet Material →		.060" 5052-H34 Aluminum		.060" Cold-Rolled Steel		.060" 300 Series Stainless Steel	
UNIFIED	Body Size - Sheet Code	Installation (lbs.)	Pushout (lbs.)	Installation (lbs.)	Pushout (lbs.)	Installation (lbs.)	Pushout (lbs.)
	SKC-6060	1600	250	3200	600	—	—
	SK4-6060	—	—	—	—	9015	720

Test Sheet Material →		1.52 mm 5052-H34 Aluminum		1.52 mm Cold-Rolled Steel		1.52 mm 300 Series Stainless Steel	
METRIC	Body Size - Sheet Code	Installation (kN)	Pushout (N)	Installation (kN)	Pushout (N)	Installation (kN)	Pushout (N)
	SKC-61.5	71	1100	14.2	2600	—	—
	SK4-61.5	—	—	—	—	40.1	3200

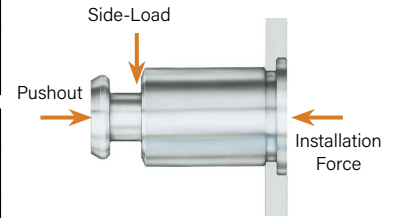

### SKC™/SK4™ STANDOFFS

#### Side-load

		Test Sheet Thick. →	.040" <sup>(2)</sup>		.060"										
UNIFIED	Body Size - Sheet Code	Test Sheet Material	Length Codes												
			-2	-4	-6	-8	-10	-12	-14	-16	-18	-20	-24	-28	-32
			Side-Load Force Max. (lbs.)												
			SKC-6060	5052-H34 Aluminum	130	95	82	63	52	44	38	34	30	27	22
SKC-6060	Cold-Rolled Steel	185	120	197	153	126	106	92	81	71	66	55	47	42	
SK4-6060	300 Series Stainless Steel	400	300	220	180	160	140	120	110	100	100	80	70	50	

		Test Sheet Thick. →	1 mm <sup>(2)</sup>		1.52 mm										
METRIC	Body Size - Sheet Code	Test Sheet Material	Length Codes												
			-2	-4	-6	-8	-10	-12	-14	-16	-18	-20	-22	-25	
			Side-Load Force Max. (N)												
			SKC-61.5	5052-H34 Aluminum	545	370	296	228	184	156	136	116	104	96	88
SKC-61.5	Cold-Rolled Steel	735	490	696	540	440	372	320	280	252	228	208	184		
SK4-61.5	300 Series Stainless Steel	1690	1140	860	710	610	540	480	440	400	380	320	250		

### SKC-F™/SK4-F™ FASTENERS

#### Installation, Pushout and Side-load

Test Sheet Material →		.060" 5052-H34 Aluminum			.060" Cold-Rolled Steel			.060" 300 Series Stainless Steel		
UNIFIED	Type	Installation (lbs.)	Pushout (lbs.)	Side-Load Force Max. (lbs.)	Installation (lbs.)	Pushout (lbs.)	Side-Load Force Max. (lbs.)	Installation (lbs.)	Pushout (lbs.)	Side-Load Force Max. (lbs.)
	SKC-F	1100	120	120	2100	160	185	—	—	—
	SK4-F	—	—	—	—	—	—	10210	292	202

Test Sheet Material →		1.52 mm 5052-H34 Aluminum			1.52 mm Cold-Rolled Steel			1.52 mm 300 Series Stainless Steel		
METRIC	Type	Installation (kN)	Pushout (N)	Side-Load Force Max. (N)	Installation (kN)	Pushout (N)	Side-Load Force Max. (N)	Installation (kN)	Pushout (N)	Side-Load Force Max. (N)
	SKC-F	4.9	533	533	9.3	711	822	—	—	—
	SK4-F	—	—	—	—	—	—	45.4	1300	900

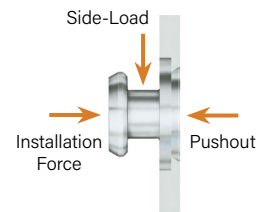

- (1) Published installation forces are for general reference. Actual set-up and confirmation of complete installation should be made by observing proper seating of fastener as described in the installation steps. Other performance values reported are averages when all proper installation parameters and procedures are followed. Variations in mounting hole size, sheet material, and installation procedure may affect performance. Performance testing this product in your application is recommended. We will be happy to provide technical assistance and/or samples for this purpose.
- (2) .040" / 1 mm test sheet material thickness was used for the -2 and -4 SKC/SK4 standoffs due to the short length of the parts.



# KEYHOLE® STANDOFFS AND FASTENERS

## SKCF™/SK4F™/SKSF™ STANDOFFS

### Installation and pushout

UNIFIED	Part No.	Test Sheet Material			
		.060" Cold-Rolled Steel		.060" 300 Series Stainless Steel	
		Installation (lbs.)	Pushout (lbs.)	Installation (lbs.)	Pushout (lbs.)
	SKCF-6060	3300	450	—	—
SKSF-6060	3300	450	—	—	
SK4F-6060	—	—	9000	560	

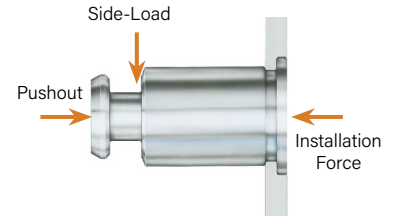

METRIC	Part No.	Test Sheet Material			
		1.5mm Cold-Rolled Steel		1.5mm 300 Series Stainless Steel	
		Installation (kN)	Pushout (N)	Installation (kN)	Pushout (N)
	SKCF-61.5	14.7	2000	—	—
SKSF-61.5	14.7	2000	—	—	
SK4F-61.5	—	—	40.1	2500	

## SKCF™/SK4F™/SKSF™ STANDOFFS

### Side-load

UNIFIED	Part No.	Test Sheet Material	Side Load Force Max. (lbs.)				
			-4	-6	-8	-10	-12
			SKCF-6060	.060" Cold-Rolled Steel	260	197	153
SKSF-6060	.060" Cold-Rolled Steel	260	197	153	126	106	
SK4F-6060	.060" 300 Series Stainless Steel	300	220	180	160	140	

METRIC	Part No.	Test Sheet Material	Side Load Force Max. (N)			
			-4	-6	-8	-10
			SKCF-61.5	1.5mm Cold-Rolled Steel	1000	696
SKSF-61.5	1.5mm Cold-Rolled Steel	1000	696	540	440	
SK4F-61.5	1.5mm 300 Series Stainless Steel	1300	860	710	610	

## SKCF-F™/SK4F-F™/SKSF-F™/TSKCF-F™/TSK4F-F™/TSKSF-F™ FASTENERS

### Installation pushout and side-load

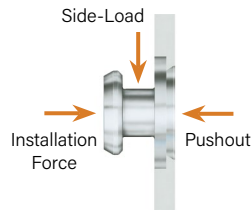

Part No.	Test Sheet Material	Installation		Pushout		Side-Load Force Max.	
		(lbs.)	(kN)	(lbs.)	(N)	(lbs.)	(N)
SKCF-F1.5	.040" / 1mm Cold-Rolled Steel	2518	11.2	160	711	185	822
SKSF-F1.5-ZI	.040" / 1mm Cold-Rolled Steel	2518	11.2	160	711	185	822
SK4F-F1.5	.040" / 1mm 300 Series Stainless Steel	7600	33.8	225	1000	202	900

Part No.	Test Sheet Material	Installation		Pushout		Side-Load Force Max.	
		(lbs.)	(kN)	(lbs.)	(N)	(lbs.)	(N)
TSKCF-F1.5	.032" / 0.8mm Cold-Rolled Steel	2203	9.8	112	500	41	180
TSKSF-F1.5-ZI	.032" / 0.8mm Cold-Rolled Steel	2203	9.8	112	500	41	180
TSK4F-F1.5	.032" / 0.8mm 300 Series Stainless Steel	6789	30.2	169	750	56	250



## SKS-R™/SKC-R™/SK4-R™ FASTENERS

### Installation pushout and side-load

Part No.	Test Sheet Material - .040" / 1mm Cold-Rolled Steel HRB 67					
	Installation		Pushout		Side-Load Force Max.	
	(lbs.)	(kN)	(lbs.)	(N)	(lbs.)	(N)
SKC-R1.5-2.5	3507	15.6	180	800	191	850
SKC-R1.5-3.2	4002	17.8	180	800	180	800
SKC-R1.5-4.0	5755	25.6	202	900	169	750
SKC-R2.0-2.5	3507	15.6	180	800	191	850
SKC-R2.0-3.2	4002	17.8	180	800	180	800
SKC-R2.0-4.0	5755	25.6	202	900	169	750
SKC-R2.5-2.5	3507	15.6	180	800	191	850
SKC-R2.5-3.2	4002	17.8	180	800	180	800
SKC-R2.5-4.0	5755	25.6	202	900	169	750

Part No.	Test Sheet Material - .040" / 1mm 300 Series Stainless Steel HRB 88					
	Installation		Pushout		Side-Load Force Max.	
	(lbs.)	(kN)	(lbs.)	(N)	(lbs.)	(N)
SK4-R1.5-2.5	6115	27.2	270	1200	214	950
SK4-R1.5-3.2	6812	30.3	292	1300	202	900
SK4-R1.5-4.0	7419	33	315	1400	191	850
SK4-R2.0-2.5	6115	27.2	270	1200	214	950
SK4-R2.0-3.2	6812	30.3	292	1300	202	900
SK4-R2.0-4.0	7419	33	315	1400	191	850
SK4-R2.5-2.5	6115	27.2	270	1200	214	950
SK4-R2.5-3.2	6812	30.3	292	1300	202	900
SK4-R2.5-4.0	7419	33	315	1400	191	850

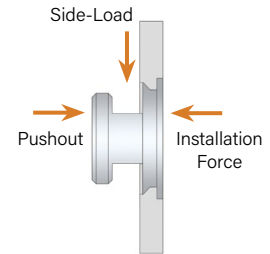

Part No.	Test Sheet Material - .040" / 1mm Cold-Rolled Steel HRB 67					
	Installation		Pushout		Side-Load Force Max.	
	(lbs.)	(kN)	(lbs.)	(N)	(lbs.)	(N)
SKS-R1.5-2.5-ZI	3200	14.2	160	711	191	850
SKS-R1.5-3.2-ZI	4000	17.8	180	800	213	950
SKS-R1.5-4.0-ZI	5000	22.3	180	800	258	1150
SKS-R2.0-2.5-ZI	3200	14.2	160	711	169	750
SKS-R2.0-3.2-ZI	4000	17.8	180	800	191	850
SKS-R2.0-4.0-ZI	5000	22.3	180	800	225	1000
SKS-R2.5-2.5-ZI	3200	14.2	160	711	124	550
SKS-R2.5-3.2-ZI	4000	17.8	180	800	137	610
SKS-R2.5-4.0-ZI	5000	22.3	180	800	182	810

## TSKC-R™/TSK4-R™/TSKS-R™ FASTENERS

### Installation pushout and side-load

Part No.	Test Sheet Material - .032" / 0.8mm Cold-Rolled Steel HRB 67					
	Installation		Pushout		Side-Load Force Max.	
	(lbs.)	(kN)	(lbs.)	(N)	(lbs.)	(N)
TSKC-R1.5-2.5	2518	11.2	124	550	45	200
TSKC-R2.0-2.5	2518	11.2	124	550	41	180
TSKC-R2.5-2.5	2518	11.2	124	550	34	150

Part No.	Test Sheet Material - .032" / 0.8mm 300 Series Stainless Steel HRB 88					
	Installation		Pushout		Side-Load Force Max.	
	(lbs.)	(kN)	(lbs.)	(N)	(lbs.)	(N)
TSK4-R1.5-2.5	5710	25.4	169	750	68	300
TSK4-R2.0-2.5	5710	25.4	169	750	63	280
TSK4-R2.5-2.5	5710	25.4	169	750	56	250

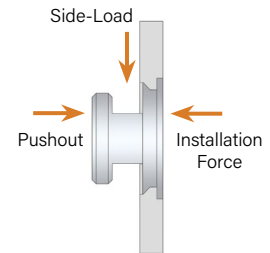

Part No.	Test Sheet Material - .032" / 0.8mm Cold-Rolled Steel HRB 67					
	Installation		Pushout		Side-Load Force Max.	
	(lbs.)	(kN)	(lbs.)	(N)	(lbs.)	(N)
TSKS-R1.5-2.5-ZI	2518	11.2	124	550	45	200
TSKS-R2.0-2.5-ZI	2518	11.2	124	550	41	180
TSKS-R2.5-2.5-ZI	2518	11.2	124	550	34	150

## PERFORMANCE DATA

### HSKC-R™/HSK4-R™/HSKS-R™ FASTENERS

#### Installation pushout and side-load

Part No.	Test Sheet Material - .047" / 1.2mm Cold-Rolled Steel HRB 67					
	Installation		Pushout		Side-Load Force Max.	
	(lbs.)	(kN)	(lbs.)	(N)	(lbs.)	(N)
HSKC-R1.5-2.5	4002	17.8	225	1000	202	900
HSKC-R1.5-3.2	5013	22.3	247	1100	191	850
HSKC-R1.5-4.0	5508	24.5	270	1200	180	800
HSKC-R2.0-2.5	4002	17.8	225	1000	202	900
HSKC-R2.0-3.2	5013	22.3	247	1100	191	850
HSKC-R2.0-4.0	5508	24.5	270	1200	180	800
HSKC-R2.5-2.5	4002	17.8	225	1000	202	900
HSKC-R2.5-3.2	5013	22.3	247	1100	191	850
HSKC-R2.5-4.0	5508	24.5	270	1200	180	800

Part No.	Test Sheet Material - .047" / 1.2mm 300 Series Stainless Steel HRB 88					
	Installation		Pushout		Side-Load Force Max.	
	(lbs.)	(kN)	(lbs.)	(N)	(lbs.)	(N)
HSK4-R1.5-2.5	7194	32	315	1400	225	1000
HSK4-R1.5-3.2	7868	35	337	1500	214	950
HSK4-R1.5-4.0	9442	42	337	1500	202	900
HSK4-R2.0-2.5	7194	32	315	1400	225	1000
HSK4-R2.0-3.2	7868	35	337	1500	214	950
HSK4-R2.0-4.0	9442	42	337	1500	202	900
HSK4-R2.5-2.5	7194	32	315	1400	225	1000
HSK4-R2.5-3.2	7868	35	337	1500	214	950
HSK4-R2.5-4.0	9442	42	337	1500	202	900

Part No.	Test Sheet Material - .047" / 1.2mm Cold-Rolled Steel HRB 67					
	Installation		Pushout		Side-Load Force Max.	
	(lbs.)	(kN)	(lbs.)	(N)	(lbs.)	(N)
HSKS-R1.5-2.5-ZI	4002	17.8	225	1000	202	900
HSKS-R1.5-3.2-ZI	5013	22.3	247	1100	191	850
HSKS-R1.5-4.0-ZI	5508	24.5	270	1200	180	800
HSKS-R2.0-2.5-ZI	4002	17.8	225	1000	202	900
HSKS-R2.0-3.2-ZI	5013	22.3	247	1100	191	850
HSKS-R2.0-4.0-ZI	5508	24.5	270	1200	180	800
HSKS-R2.5-2.5-ZI	4002	17.8	225	1000	202	900
HSKS-R2.5-3.2-ZI	5013	22.3	247	1100	191	850
HSKS-R2.5-4.0-ZI	5508	24.5	270	1200	180	800

All PEM® products meet our stringent quality standards. If you require additional industry or other specific [quality certifications](#), special procedures and/or part numbers are required. Please contact your local sales office or representative for further information.

Regulatory [compliance information](#) is available in Technical Support section of our website. Specifications subject to change without notice. See our website for the most current version of this bulletin.

**PennEngineering®**



**North America:** Danboro, Pennsylvania USA ▪ E-mail: [info@pemnet.com](mailto:info@pemnet.com) ▪ Tel: +1-215-766-8853 ▪ 800-237-4736 (USA)

**Europe:** Galway, Ireland ▪ E-mail: [europa@pemnet.com](mailto:europa@pemnet.com) ▪ Tel: +353-91-751714

**Asia/Pacific:** Singapore ▪ E-mail: [singapore@pemnet.com](mailto:singapore@pemnet.com) ▪ Tel: +65-6-745-0660

Shanghai, China ▪ E-mail: [china@pemnet.com](mailto:china@pemnet.com) ▪ Tel: +86-21-5868-3688

Visit our PEMNET™ Resource Center at [www.pemnet.com](http://www.pemnet.com) ▪ Technical support e-mail: [techsupport@pemnet.com](mailto:techsupport@pemnet.com)

## X-ON Electronics

Largest Supplier of Electrical and Electronic Components

*Click to view similar products for [Screws & Fasteners](#) category:*

*Click to view products by [PEM manufacturer](#):*

Other Similar products are found below :

[5721-1440-1/4-SS](#) [0098.0094](#) [0098.9206](#) [0098.9219](#) [0098.9221](#) [59781-6](#) [0098.9212](#) [618-00001](#) [6292-1](#) [690432-1](#) [699161-000](#) [700989](#)  
[7230-3](#) [72609-02](#) [CAPTIVE JACK SCREW](#) [73542-02](#) [CAPTIVE SHORT THUMBSCREW](#) [745564-1](#) [751-00001](#) [7680](#) [809704-1](#) [8700](#)  
[8860220](#) [9521](#) [992763-3](#) [1-18024-0](#) [A168P1](#) [1-24921-1](#) [125416-1](#) [1301810148](#) [1301810313](#) [1301810400](#) [1301830031](#) [1-306131-6](#)  
[1301810131](#) [1301830042](#) [1393160-3](#) [1458](#) [1-59781-3](#) [18029-4](#) [NBX-10953](#) [NUT-16-3P-HEX-NICKEL](#) [2079764-1](#) [20993.45098](#) [21004-1](#)  
[21009-4](#) [21014-5](#) [21021-2](#) [CA24037A01](#) [22987-4](#) [2-305927-7](#) [2327](#)