



PEM® brand SNAP-TOP® standoffs are designed for permanent installation into metal panels or PC Boards



SSA™

SNAP-TOP® STANDOFFS

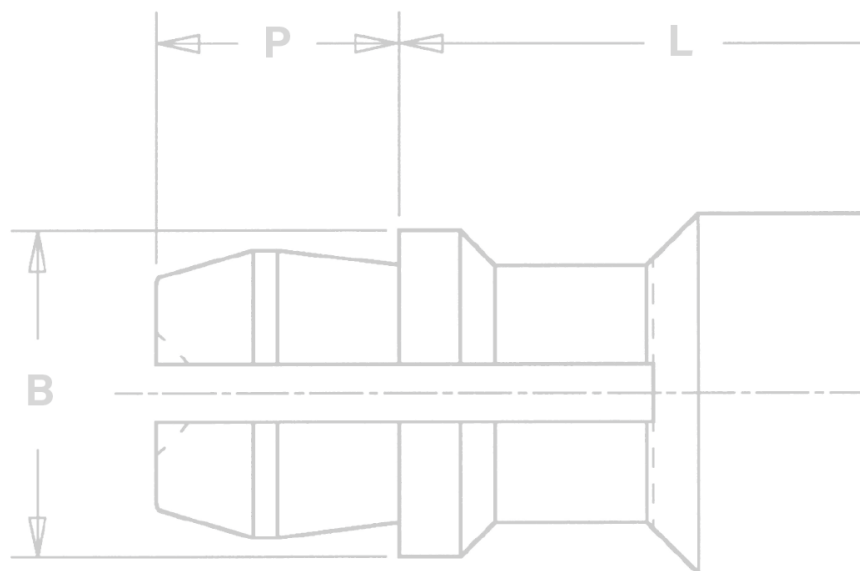

SNAP-TOP® STANDOFFS

PEM® SNAP-TOP® Standoffs are designed for permanent installation into metal panels or PC boards.

- Spring action to hold PC Boards and subassemblies securely.
- Allows for quick removal.
- Eliminates screws and other threaded hardware.
 - Less parts to handle during assembly.
 - Less risk of damaging delicate circuitry because of loose parts falling into your equipment.
- Available in three different mounting styles:
 - Self-clinching for installation into ductile materials
 - Broaching for installation into PC Board and brittle material.
 - Surface mount for installation to PC Board
- Permanently installed in the panel.

Installation forces, pushout and snap forces are listed on page 7.

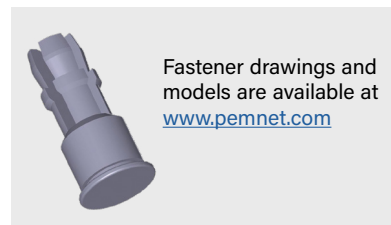
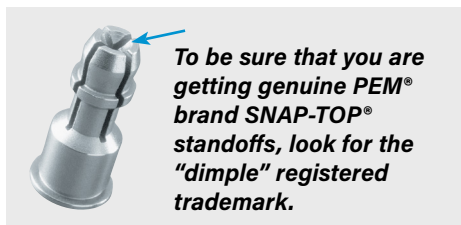
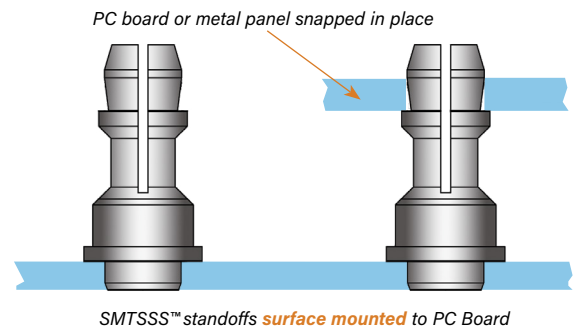
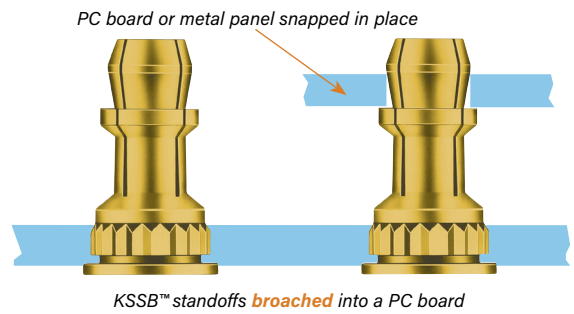
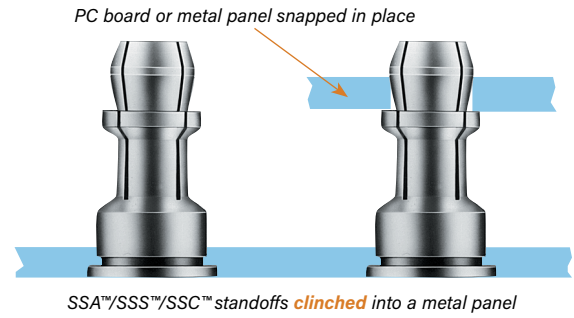

SNAP-TOP® STANDOFFS

SSA™/SSS™/SSC™ STANDOFFS FOR CLINCHING INTO METAL SHEETS

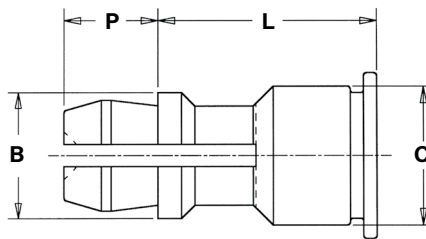
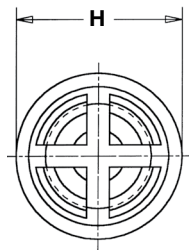

PART NUMBER DESIGNATION

SS	A	-	156	-	10	
SS	S	-	156	-	10	ZI
SS	C	-	156	-	10	
↓	↓		↓		↓	↓
Type	Material		Mounting Hole A Diameter Code		Length Code	Finish

FASTENER MATERIAL:

SSA: Aluminum
 SSS: Carbon Steel
 SSC: 400 Series Stainless Steel

FINISH:

SSA: Natural
 SSS: ZI - Zinc plated per ASTM B633, SC1 (5µm), Type III, colorless, plus clear chromate ⁽¹⁾
 SSC: Passivated and/or tested per ASTM A380

All dimensions are in inches.

UNIFIED	Type			Panel 2 (Top) Mounting Hole Diameter Code	Length Code "L" ±.005 (Length Code in 32nds of an inch)									B ±.005	C Max.	H ±.005	P ±.005	
	Fastener Material																	
	Aluminum	Carbon Steel	Stainless Steel															
	SSA	SSS	SSC	156	.250	.312	.375	.437	.500	.562	.625	.750	.875	1.00				
					8	10	12	14	16	18	20	24	28	32 ⁽²⁾	.188	.212	.250	.141

All dimensions are in millimeters.

METRIC	Type			Panel 2 (Top) Mounting Hole Diameter Code	Length Code "L" ±0.13 (Length Code in millimeters)									B ±0.13	C Max.	H ±0.13	P ±0.13
	Fastener Material																
	Aluminum	Carbon Steel	Stainless Steel														
	SSA	SSS	SSC	4MM	8	10	12	14	16	18	20	22	25 ⁽²⁾	4.78	5.39	6.35	3.58

(1) See PEM Technical Support section of our web site for related plating standards and specifications.

(2) This length not available for Type SSA aluminum fasteners.

APPLICATION DATA

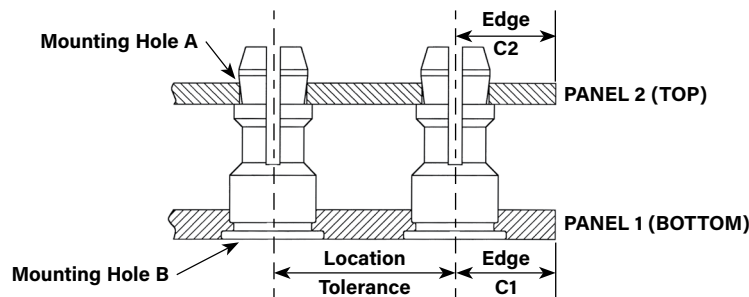

All dimensions are in inches.

UNIFIED	Panel 1							Panel 2				
	Type	Hardness Max. (2)	Bottom Mounting Hole B +.003 -.000	Panel Material	Thickness Min.	Edge Distance C ₁ Min.	Location Tolerance	Hardness Max.	Top Mounting Hole A +.003 -.000	Panel Material	Thickness Range (3)	Edge Distance C ₂ Min.
		SSA	HRB 50 / HB 82	.213	Metal	.040	.260	±.005	No Limit	.156	PC Board or Metal	.040 -.070
	SSS	HRB 60 / HB 107										
	SSC	HRB 70 / HB 125										

All dimensions are in millimeters.

METRIC	Panel 1							Panel 2				
	Type	Hardness Max. (2)	Bottom Mounting Hole B +0.08	Panel Material	Thickness Min.	Edge Distance C ₁ Min.	Location Tolerance	Hardness Max.	Top Mounting Hole A +0.08	Panel Material	Thickness Range (3)	Edge Distance C ₂ Min.
		SSA	HRB 50 / HB 82	5.41	Metal	1	6.6	±0.13	No Limit	4	PC Board or Metal	1 - 1.8
	SSS	HRB 60 / HB 107										
	SSC	HRB 70 / HB 125										

(2) HRB - Hardness Rockwell "B" Scale. HB - Hardness Brinell.

(3) Available for thicker boards on special order.

KSSB™ STANDOFFS FOR BROACHING INTO PC BOARDS

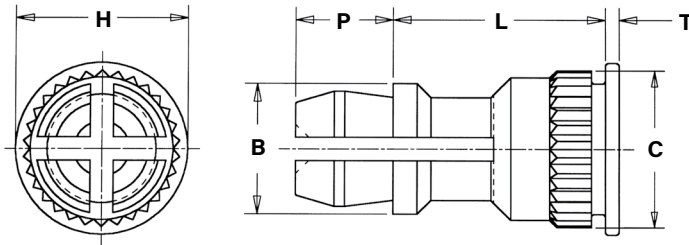

PART NUMBER DESIGNATION

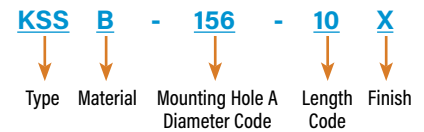

FASTENER MATERIAL:

Brass

FINISH:

Standard: X - Plain

Optional: ET - Electro-plated Tin, ASTM B545 Class B (5µm) with preservative coating, annealed ⁽¹⁾

(Optional ET finish is available on special order with additional charge.)

All dimensions are in inches.

UNIFIED	Type	Panel 2 (Top) Mounting Hole Diameter Code	Length Code "L" ±.005 (Length Code in 32nds of an inch)										B ±.005	C ±.003	H ±.005	P ±.005	T ±.005
			.250	.312	.375	.437	.500	.562	.625	.750	.875	1.00					
KSSB	156	8	10	12	14	16	18	20	24	28	32	.188	.226	.250	.141	.020	

All dimensions are in millimeters.

METRIC	Type	Panel 2 (Top) Mounting Hole Diameter Code	Length Code "L" ±0.13 (Length Code in millimeters)									B ±0.13	C ±0.08	H ±0.13	P ±0.13	T ±0.13
			8	10	12	14	16	18	20	22	25					
KSSB	4MM	8	10	12	14	16	18	20	22	25	4.78	5.74	6.35	3.58	0.51	

(1) See PEM Technical Support section of our web site for related plating standards and specifications.

APPLICATION DATA

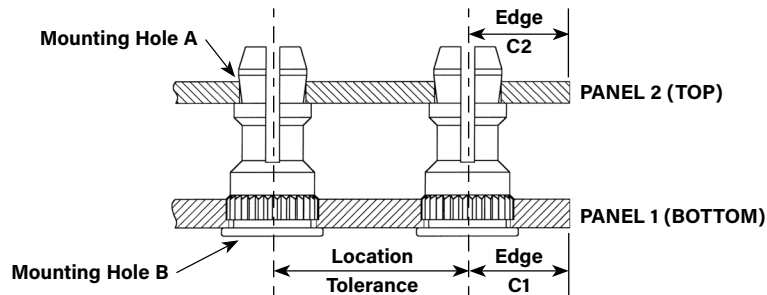

All dimensions are in inches.

UNIFIED	Type	Panel 1						Panel 2				
		Hardness Max. (2)	Bottom Mounting Hole B +.003 -.000	Panel Material	Thickness Min.	Edge Distance C ₁ Min.	Location Tolerance	Hardness Max.	Top Mounting Hole A +.003 -.000	Panel Material	Thickness Range (3)	Edge Distance C ₂ Min.
		KSSB	HRB 65 / HB 116	.213	PC Board	.050	.220	±.005	No Limit	.156	PC Board or Metal	.040 - .070

All dimensions are in millimeters.

METRIC	Type	Panel 1						Panel 2				
		Hardness Max. (2)	Bottom Mounting Hole B +0.08	Panel Material	Thickness Min.	Edge Distance C ₁ Min.	Location Tolerance	Hardness Max.	Top Mounting Hole A +0.08	Panel Material	Thickness Range (3)	Edge Distance C ₂ Min.
		KSSB	HRB 65 / HB 116	5.41	PC Board	1.27	5.59	±0.13	No Limit	4	PC Board or Metal	1 - 1.8

(2) HRB - Hardness Rockwell "B" Scale. HB - Hardness Brinell.

(3) Available for thicker boards on special order.



SNAP-TOP® STANDOFFS

SMTSSS™ REELFAST® SNAP-TOP® STANDOFFS



NOTE: REELFAST® SNAP-TOP® SMTSSS™ standoffs are for on-only applications. For removal applications, mounting hole A can be increased to reduce removal force.

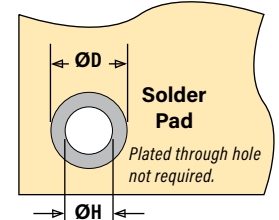
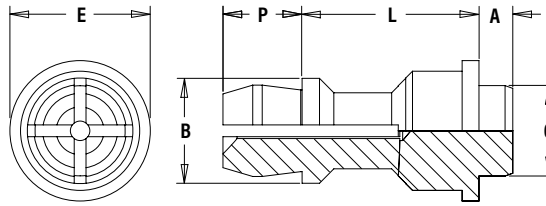

FASTENER MATERIAL:

Carbon Steel

FINISH:

ET - Electro-plated Tin, ASTM B545 Class A with clear preservative coating, annealed ⁽¹⁾⁽²⁾

(1) See PEM Technical Support section of our web site for related plating standards and specifications.

(2) Optimal solderability life noted on packaging.

All dimensions are in inches.

UNIFIED	Top Board Mounting Hole A Diameter Code	Type and Material	Length Code "L" ±.005 (Length Code in 32nds of an inch)		Min. Sheet Thickness	A Max.	C Max.	E ±.005	B ±.005	P ±.005	ØH Hole Size in Sheet +.003 -.000	ØD Min. Solder Pad
			.250	.375								
	156	SMTSSS	8	12	.060	.060	.161	.250	.188	.141	.166	.276

All dimensions are in millimeters.

METRIC	Top Board Mounting Hole A Diameter Code	Type and Material	Length Code "L" ±0.13 (Length Code in millimeters)			Min. Sheet Thickness	A Max.	C Max.	E ±0.13	B ±0.13	P ±0.13	ØH Hole Size in Sheet +0.08	ØD Min. Solder Pad
			6	8	10								
	4MM	SMTSSS	6	8	10	1.53	1.53	4.09	6.35	4.8	3.58	4.22	7

NUMBER OF PARTS PER REEL

Type, Material and Size	Length Code / Number of Parts per Reel		
SMTSSS-156	-8 / 280	-12 / 220	
SMTSSS-4MM	-6 / 300	-8 / 250	-10 / 200

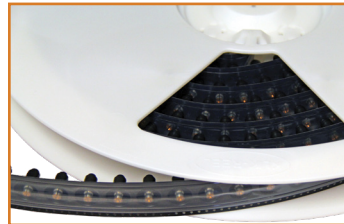

PART NUMBER DESIGNATION

SMTSS S - 156 - 12 ET
 ↓ ↓ ↓ ↓ ↓
 Type Material Mounting Hole A Length Finish
 Diameter Code Code

Packaged on 330 mm recyclable reels. Tape width is 24 mm.
 Supplied with polyimide patch for vacuum pick up.
 Reels conform to EIA-481.

APPLICATION DATA

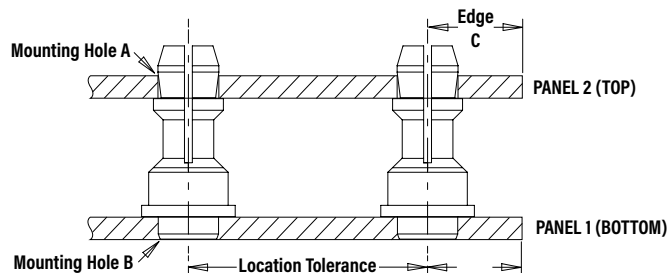

All dimensions are in inches.

UNIFIED	Panel 1					Panel 2					
	Type and Material	Hardness Max.	Bottom Mounting Hole B +.003 -.000	Panel Material	Thickness Min.	Location Tolerance	Hardness Max.	Top Mounting Hole A +.003 -.000	Panel Material	Thickness Range	Edge Distance C Min.
	SMTSSS	No Limit	.166	P.C. Board	.060	±.005	No Limit	.156	P.C. Board or Metal	.040 - .070	.100

All dimensions are in millimeters.

METRIC	Panel 1					Panel 2					
	Type and Material	Hardness Max.	Bottom Mounting Hole B +0.08	Panel Material	Thickness Min.	Location Tolerance	Hardness Max.	Top Mounting Hole A +0.08	Panel Material	Thickness Range	Edge Distance C Min.
	SMTSSS	No Limit	4.22	P.C. Board	1.53	±0.13	No Limit	4	P.C. Board or Metal	1 - 1.8	2.54

INSTALLATION

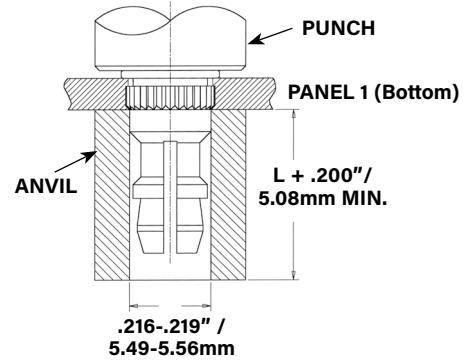
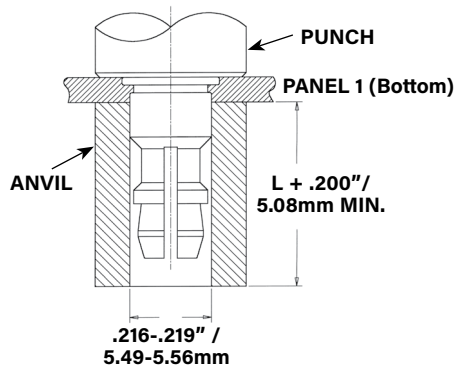

SSA™/SSS™/SSC™ Standoffs

1. Prepare properly sized mounting hole in Panel 1 (Bottom).
2. Place the fastener through the mounting hole (preferably the punch side) of the panel and into the anvil as shown in the drawing.
3. With punch and anvil surfaces parallel, apply only enough squeezing force to embed the head flush with the panel.

KSSB™ Standoffs

1. Prepare properly sized mounting hole in Panel 1 (Bottom).
2. Place the fastener through the mounting hole of the board and into the anvil as shown in the drawing.
3. With punch and anvil surfaces parallel, apply only enough squeezing force to bring the head into contact with the board.

PEMSERTER® Installation Tooling

Type	Anvil Part Number	Punch Part Number
SSA, SSS, SSC, KSSB	970200015300	975200048

SMTSSS™ Standoffs

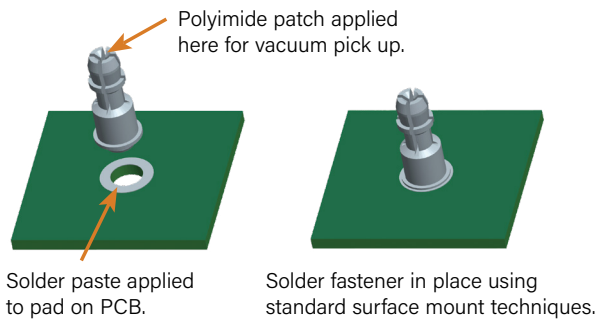

INSTALLATION NOTES

- For best results we recommend using a HAEGER® or PEMSERTER® machine for installation of PEM® self-clinching fasteners. Please check our website for more information.
- Visit the Animation Library on our website to view the installation process [for select products](#).

PERFORMANCE DATA⁽¹⁾

SSA™/SSS™/SSC™ Standoffs - Self-clinching

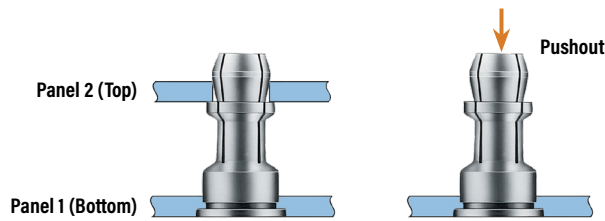

KSSB™ Standoffs - Broaching

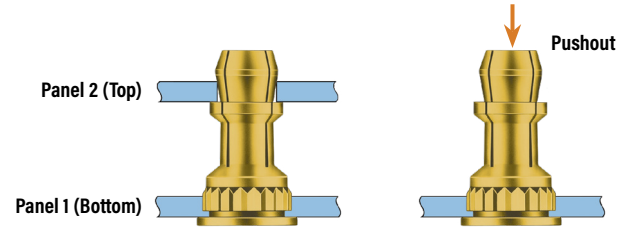

UNIFIED	Type	Panel 1 (Bottom)			Panel 2 (Top) (Removable)		
		Test Sheet Material	Installation (lbs.)	Pushout (lbs.)	Max. First on Snap Force (lbs.)	Min. First off Snap Force (lbs.)	Min. 15th off Snap Force (lbs.)
	SSA	Aluminum	1500	200	13	3	1
	SSS	Aluminum	1500	200	20	6	2
	SSC	Aluminum	1500	200	20	6	2
	SSS	Cold-rolled Steel	3600	400	20	6	2
	SSC	Cold-rolled Steel	3600	400	20	6	2
	KSSB	FR-4 Fiberglass	500	110	13	3	1

METRIC	Type	Panel 1 (Bottom)			Panel 2 (Top) (Removable)		
		Test Sheet Material	Installation (kN)	Pushout (N)	Max. First on Snap Force (N)	Min. First off Snap Force (N)	Min. 15th off Snap Force (N)
	SSA	Aluminum	6.7	890	58	13	4
	SSS	Aluminum	6.7	890	89	27	9
	SSC	Aluminum	6.7	890	89	27	9
	SSS	Cold-rolled Steel	16	1780	89	27	9
	SSC	Cold-rolled Steel	16	1780	89	27	9
	KSSB	FR-4 Fiberglass	2.2	484	58	13	4

SMTSSS™ Standoffs - Surface Mount

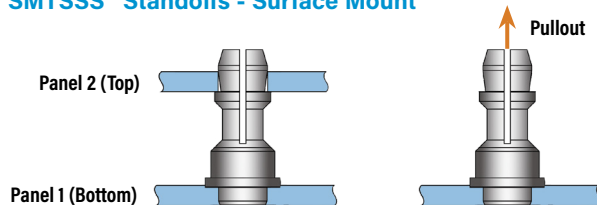

Type, Material and Size	Panel 1 (Bottom)		Panel 2 (Top)	
	Test Sheet Material	Pullout ⁽²⁾	Max. Snap-on Force	Min. Snap Retention Force
SMTSSS-156	.062" Single Layer FR-4	113 lbs.	20 lbs.	6 lbs.
SMTSSS-4MM	1.58 mm Single Layer FR-4	500 N	89 N	27 N

TESTING CONDITIONS

Oven	Quad ZCR convection oven with 4 zones
High Temp	473 °F / 245 °C
Board Finish	62% Sn, 38% Pb
Board	.062" / 1.58 mm thick, Single Layer FR-4
Screen Printer	Ragin Manual Printer
Vias	None
Spokes	2 Spoke Pattern
Paste	Alpha CVP-390 Sn96.5/3.0Ag/0.5Cu (SAC305)
Stencil	.0067" / 0.17 mm thick

(1) Published installation forces are for general reference. Actual set-up and confirmation of complete installation should be made by observing proper seating of fastener as described in the installation steps. Other performance values reported are averages when all proper installation parameters and procedures are followed. Variations in mounting hole size, sheet material, and installation procedure may affect performance. Performance testing this product in your application is recommended. We will be happy to provide technical assistance and/or samples for this purpose.

(2) With lead-free paste. Average values of 30 test points. The data presented here is for general comparison purposes only. Actual performance is dependent upon application variables. We will be happy to provide samples for you to install. If required, we can also test your installed hardware and provide you with the performance data specific to your application.

All PEM® products meet our stringent quality standards. If you require additional industry or other specific [quality certifications](#), special procedures and/or part numbers are required. Please contact your local sales office or representative for further information.

Regulatory [compliance information](#) is available in Technical Support section of our website. Specifications subject to change without notice. See our website for the most current version of this bulletin.

PennEngineering®



North America: Danboro, Pennsylvania USA ▪ E-mail: info@pemnet.com ▪ Tel: +1-215-766-8853 ▪ 800-237-4736 (USA)

Europe: Galway, Ireland ▪ E-mail: europa@pemnet.com ▪ Tel: +353-91-751714

Asia/Pacific: Singapore ▪ E-mail: singapore@pemnet.com ▪ Tel: +65-6-745-0660

Shanghai, China ▪ E-mail: china@pemnet.com ▪ Tel: +86-21-5868-3688

Visit our PEMNET™ Resource Center at www.pemnet.com ▪ Technical support e-mail: techsupport@pemnet.com

X-ON Electronics

Largest Supplier of Electrical and Electronic Components

Click to view similar products for [Standoffs & Spacers](#) category:

Click to view products by [PEM manufacturer](#):

Other Similar products are found below :

[588-6208-02](#) [599-9844-02](#) [M0516-3-N](#) [M0518-3-N](#) [M0521-3-N](#) [M0524-3-N](#) [M0532-35-N](#) [M0543-4-AL](#) [M0544-35-N](#) [M0544-3-N](#) [M0545-3-AL](#) [M0553-3-N](#) [M0608-5-SS](#) [M0609-5-SS](#) [M0651-5-SS](#) [M0653-35-N](#) [M0654-4-SS](#) [M0655-5-AL](#) [M0658-35-AL](#) [M0660-4-AL](#) [M0660-4-N](#) [M0670-35-N](#) [M0671-5-N](#) [M0671-5-SS](#) [M0722-5-N](#) [M0725-6-N](#) [M0904-B-25-AL](#) [M1273-2545-AL](#) [M1273-2545-SS](#) [M1273-3005-AL](#) [M1273-3005-SS](#) [M1274-3005-AL](#) [60187](#) [60202-SP](#) [60273](#) [60335-SP](#) [60348-SP](#) [60419-SP](#) [60425-SP](#) [60473-SP](#) [60475-SP](#) [60477-SP](#) [60489-SP](#) [60491-SP](#) [60585-SP](#) [60762-SP](#) [60763-SP](#) [60872-SP](#) [M1303-3506-AL](#) [M1307-3506-AL](#)