

UltraCMOS® Digitally Tunable Capacitor (DTC) 100-3000 MHz

### Product Description

PE64908 is a DuNE™ technology-enhanced Digitally Tunable Capacitor (DTC) based on Peregrine's UltraCMOS® technology. This highly versatile product supports a wide variety of tuning circuit topologies with emphasis on impedance matching and aperture tuning applications.

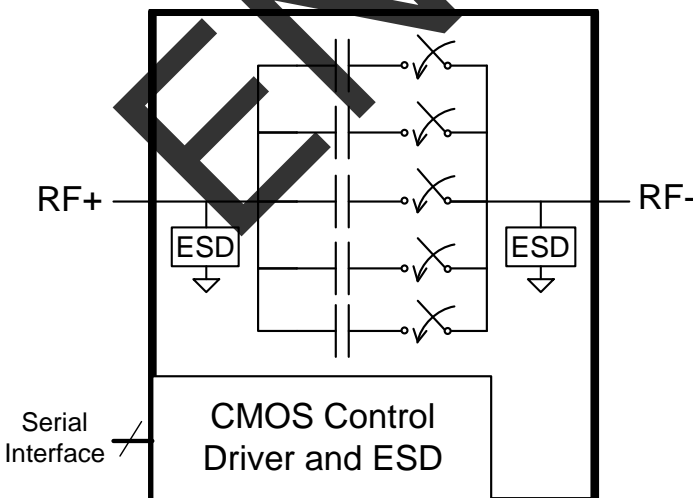
PE64908 offers high RF power handling and ruggedness while meeting challenging harmonic and linearity requirements enabled by Peregrine's HaRP™ technology. The device is controlled through the widely supported 3-wire (SPI compatible) interface. All decoding and biasing is integrated on-chip and no external bypassing or filtering components are required.

DuNE™ devices feature ease of use while delivering superior RF performance in the form of tuning accuracy, monotonicity, tuning ratio, power handling, size, and quality factor. With built-in bias voltage generation and ESD protection, DTC products provide a monolithically integrated tuning solution for demanding RF applications.

### Features

- 3-wire (SPI compatible) serial interface with built-in bias voltage generation and ESD protection
- DuNE™ technology enhanced
- 5-bit 32-state Digitally Tunable Capacitor
- Shunt configuration  $C = 2.15 \text{ pF}$  to  $7.7 \text{ pF}$  (3.6:1 tuning ratio) in discrete 180 fF steps
- High RF power handling ( $30 \text{ V}_{\text{pk}}$  RF) and linearity
- Wide power supply range (2.3 to 4.8V) for and low current consumption (typ. 140  $\mu\text{A}$  at 2.75V)
- High ESD tolerance of 2kV HBM on all pins
- Applications include:
  - Tunable antennas
  - Tunable matching networks
  - Tunable filter networks
  - Phase shifters

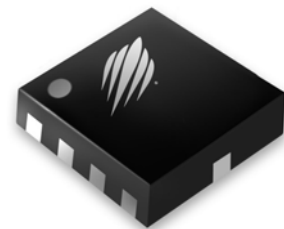
Figure 1. Functional Diagram



DOC-02169

Figure 2. Package Type

10-lead 2 x 2 x 0.55 mm QFN



**Table 1. Electrical Specifications @ 25°C, V<sub>DD</sub> = 2.75V (In shunt configuration, RF- connected to GND)**

Parameter	Condition	Min	Typ	Max	Unit
Operating frequency		100		3000	MHz
Minimum capacitance (C <sub>min</sub> )	State 00000, 100 MHz	1.93	2.15	2.37	pF
Maximum capacitance (C <sub>max</sub> )	State 11111, 100 MHz	6.93	7.70	8.47	pF
Tuning ratio	C <sub>max</sub> /C <sub>min</sub> , 100 MHz		3.61		
Step size	5 bits (32 states), 100 MHz		0.180		pF
Quality factor at C <sub>min</sub> <sup>1</sup>	698 - 960 MHz, with L <sub>S</sub> removed 1710 - 2170 MHz, with L <sub>S</sub> removed		41 24		
Quality factor at C <sub>max</sub> <sup>1</sup>	698 - 960 MHz, with L <sub>S</sub> removed 1710 - 2170 MHz, with L <sub>S</sub> removed		15 6		
Self resonant frequency <sup>5</sup>	State 00000 State 11111		3.9 2.1		GHz
Harmonics <sup>2</sup>	2fo, 3fo: 698 - 915 MHz; P <sub>IN</sub> +34 dBm, 50Ω 2fo, 3fo: 1710 - 1910 MHz; P <sub>IN</sub> +32 dBm, 50Ω			-36 -36	dBm dBm
IMD3	Bands I,II,V/VIII, +20 dBm CW @ TX freq, -15 dBm CW @ 2Tx-Rx freq, 50 Ω			-105	dBm
Third order intercept point (IP3)	Shunt configuration derived from IMD3 spec IP3 = (2P <sub>TX</sub> + P <sub>block</sub> - IMD3) / 2		65		dBm
Switching time <sup>3,4</sup>	State change to 10/90% delta capacitance between any two states			12	μs
Start-up time <sup>3</sup>	Time from V <sub>DD</sub> within specification to all performances within specification			70	μs
Wake-up time <sup>3,4</sup>	State change from Standby mode to RF state to all performances within specification			70	μs

Notes: 1. Q for a Shunt DTC based on a Series RLC equivalent circuit  
 $Q = X_C / R = (X - X_L) / R$ , where  $X = X_L + X_C$ ,  $X_L = 2\pi f * L$ ,  $X_C = -1 / (2\pi f * C)$  which is equal to removing the effect of parasitic inductance L<sub>S</sub>  
 2. In Shunt between 50Ω ports. Pulsed RF input with 4620 μs period, 50% duty cycle, measured per 3GPP TS 45.005  
 3. DC path to ground at RF- must be provided to achieve specified performance  
 4. State change activated on falling edge of SEN following data word  
 5. DTC operation above SRF is possible

Figure 3. Pin Configuration (Top View)

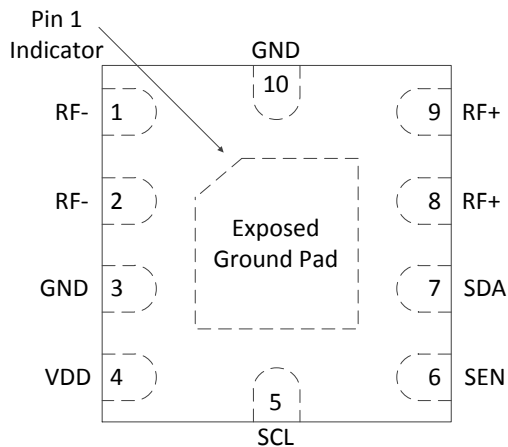


Table 2. Pin Descriptions

Pin #	Pin Name	Description
1	RF-	Negative RF port <sup>1</sup>
2	RF-	Negative RF port <sup>1</sup>
3	GND	Ground <sup>2</sup>
4	V <sub>DD</sub>	Power supply pin
5	SCL	Serial interface clock input
6	SEN	Serial interface latch enable input
7	SDA	Serial interface data input
8	RF+	Positive RF port <sup>1</sup>
9	RF+	Positive RF port <sup>1</sup>
10	GND	Ground <sup>2</sup>
Pad	GND	Exposed pad: ground for proper operation <sup>2</sup>

Notes: 1. For optimal performance, recommend tying Pins 1-2 and Pins 8-9 together on PCB  
2. For optimal performance, recommend tying Pins 3, 10 and exposed ground pad together on PCB

### Moisture Sensitivity Level

The Moisture Sensitivity Level rating for the PE64908 in the 10-lead 2 x 2 x 0.55 mm QFN package is MSL1.

Table 3. Operating Ranges

Parameter	Symbol	Min	Typ	Max	Unit
Supply voltage	V <sub>DD</sub>	2.30	2.75	4.80	V
Supply current (V <sub>DD</sub> = 2.75V)	I <sub>DD</sub>		140	200	µA
Standby current (V <sub>DD</sub> = 2.75V)	I <sub>DD</sub>		25		µA
Digital input high	V <sub>IH</sub>	1.2	1.8	3.1	V
Digital input low	V <sub>IL</sub>	0	0	0.57	V
RF input power (50Ω) <sup>1</sup> 698 - 915 MHz 1710 - 1910 MHz				+34 +32	 dBm
Peak operating RF voltage V <sub>P</sub> to V <sub>M</sub> V <sub>P</sub> to RFGND				30 30	V <sub>pk</sub> V <sub>pk</sub>
Operating temperature range	T <sub>OP</sub>	-40	+25	+85	°C
Storage temperature range	T <sub>ST</sub>	-65	+25	+150	°C

Notes: 1. Maximum power available from 50Ω source. Pulsed RF input with 4620 µs period, 50% duty cycle, measured per 3GPP TS 45.005 measured in shunt between 50Ω ports, RF- connected to GND  
2. Node voltages defined per Equivalent Circuit Model Schematic (Figure 13). When DTC is used as a part of reactive network, impedance transformation may cause the internal RF voltages (V<sub>P</sub>, V<sub>M</sub>) to exceed peak operating RF voltage even with specified RF input power levels. For operation above about +20 dBm (100 mW), the complete RF circuit must be simulated using actual input power and load conditions, and internal node voltages (V<sub>P</sub>, V<sub>M</sub> in Figure 13) monitored to not exceed 30 V<sub>pk</sub>

Table 4. Absolute Maximum Ratings

Parameter/Condition	Symbol	Min	Max	Unit
ESD Voltage HBM <sup>1</sup>	V <sub>ESD</sub>		2000	V

Note 1: Human Body Model (MIL-STD-883 Method 3015.7)

Exceeding absolute maximum ratings may cause permanent damage. Operation should be restricted to the limits in the Operating Ranges table. Operation between operating range maximum and absolute maximum for extended periods may reduce reliability.

### Electrostatic Discharge (ESD) Precautions

When handling this UltraCMOS<sup>®</sup> device, observe the same precautions that you would use with other ESD-sensitive devices. Although this device contains circuitry to protect it from damage due to ESD, precautions should be taken to avoid exceeding the specified rating.

### Latch-Up Avoidance

Unlike conventional CMOS devices, UltraCMOS<sup>®</sup> devices are immune to latch-up.

Performance Plots @ 25°C and 2.75V unless otherwise specified

Figure 4. Measured Shunt C (@ 100 MHz) vs State

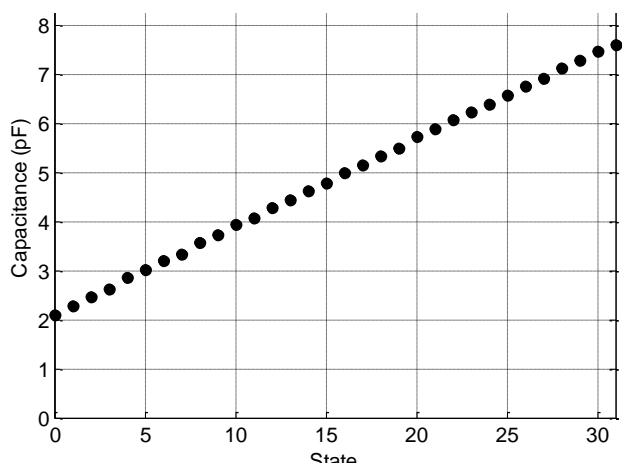


Figure 5. Measured Shunt S<sub>11</sub> (major states)

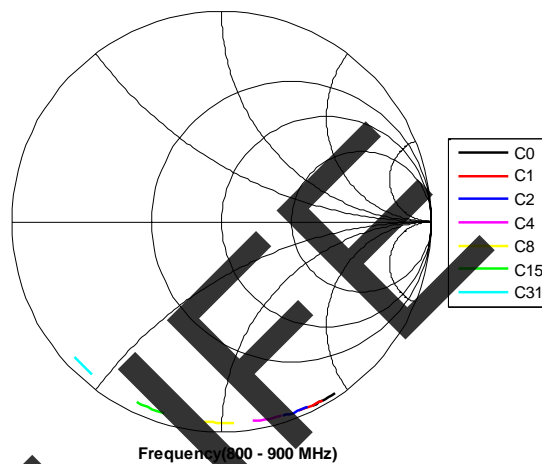


Figure 6. Measured Step Size vs State (frequency)

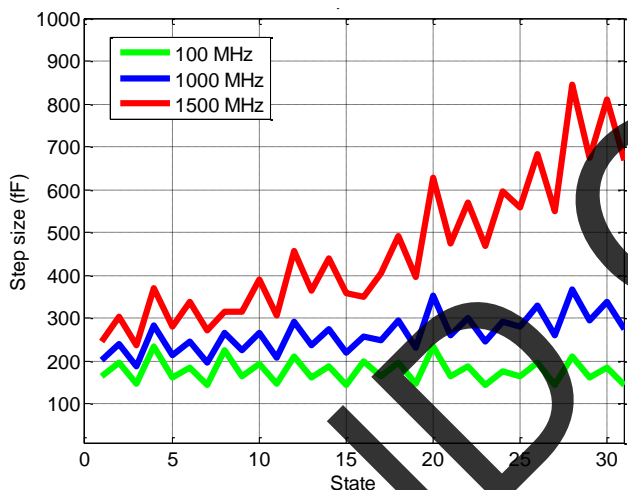


Figure 7. Measured Shunt C vs Frequency (major states)

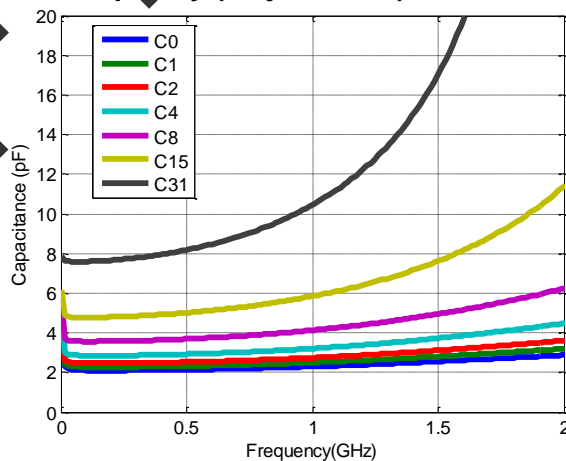


Figure 8. Measured Shunt Q vs Frequency (major states)

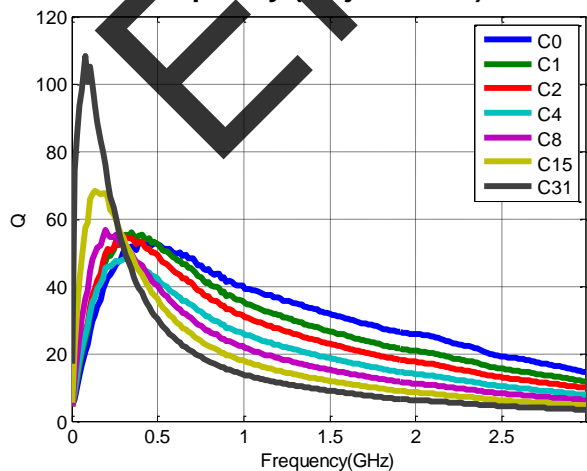
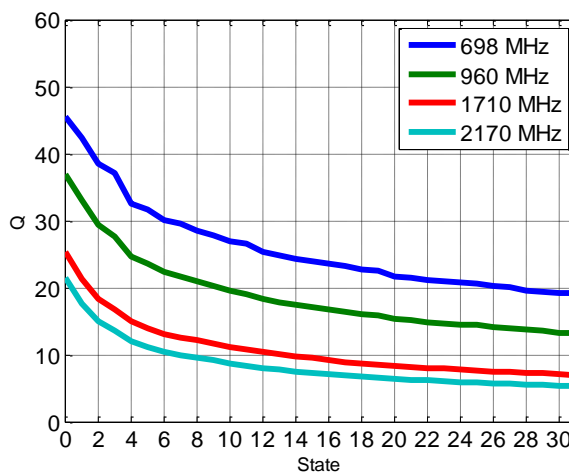


Figure 9. Measured Shunt Q vs State



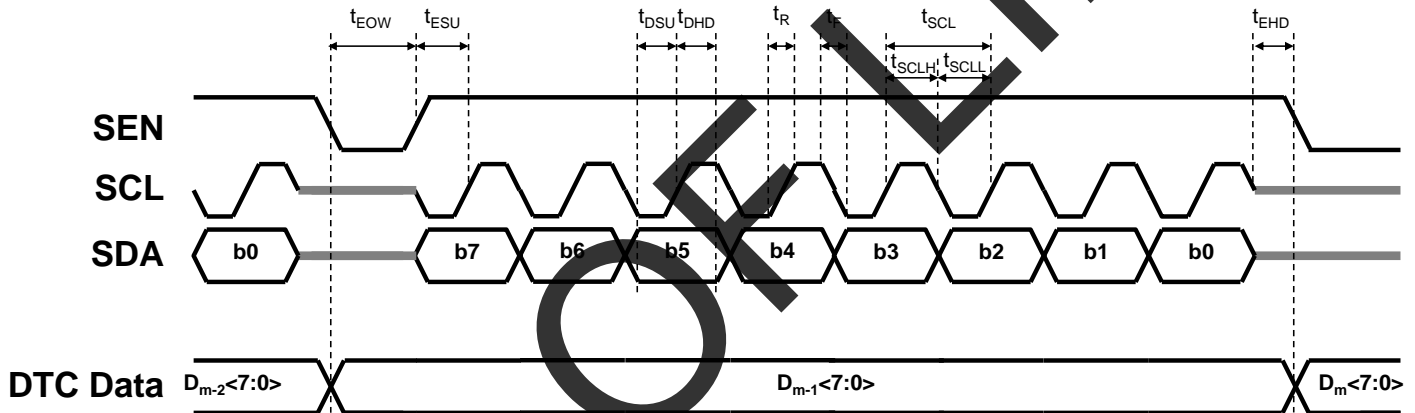
### Serial Interface Operation and Sharing

The PE64908 is controlled by a three wire SPI-compatible interface with enable active high. As shown in *Figure 10*, the serial master initiates the start of a telegram by driving the SEN (Serial Enable) line high. Each bit of the 8-bit telegram (MSB first in) is clocked in on the rising edge of SCL (Serial Clock), as shown in *Table 5* and *Figure 10*. Transitions on SDA (Serial Data) are allowed on the falling edge of SCL. The DTC activates the data on the falling edge of SEN. The DTC does not count how many bits are clocked and only maintains the last 8 bits it received.

More than 1 DTC can be controlled by one interface by utilizing a dedicated enable (SEN) line for each DTC. SDA, SCL, and  $V_{DD}$  lines may be shared as shown in *Figure 11*. Dedicated SEN lines act as a chip select such that each DTC will only respond to serial transactions intended for them. This makes each DTC change states sequentially as they are programmed.

Alternatively, a dedicated SDA line with common SEN can be used. This allows all DTCs to change states simultaneously, but requires all DTCs to be programmed even if the state is not changed.

**Figure 10. Serial Interface Timing Diagram**



**Table 5. 8-Bit Serial Programming Register Map**

b7	b6	b5	b4	b3	b2	b1	b0
0 <sup>1</sup>	0 <sup>1</sup>	STB <sup>2</sup>	d4	d3	d2	d1	d0

MSB (first in)

LSB (last in)

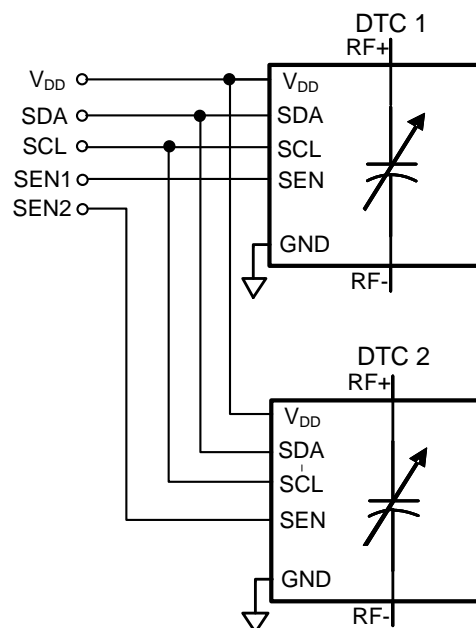
Notes: 1. These bits are reserved and must be written to 0 for proper operation  
2. The DTC is active when low (set to 0) and in low-current stand-by mode when high (set to 1)

**Table 6. Serial Interface Timing Characteristics**

$V_{DD} = 2.75V, -40^{\circ}C < T_A < +85^{\circ}C$ , unless otherwise specified

Symbol	Parameter	Min	Max	Unit
$t_{SCL}$	Serial Clock Period	38.4		ns
$t_{SCLL}$	SCL Low Time	13.2		ns
$t_{SCLH}$	SCL High Time	13.2		ns
$t_R$	SCL, SDA, SEN Rise Time		6.5	ns
$t_F$	SCL, SDA, SEN Fall Time		6.5	ns
$t_{ESU}$	SEN rising edge to SCL rising edge	19.2		ns
$t_{EHD}$	SCL rising edge to SEN falling edge	19.2		ns
$t_{DSU}$	SDA valid to SCL rising edge	13.2		ns
$t_{DHD}$	SDA valid after SCL rising edge	13.2		ns
$t_{EOW}$	SEN falling edge to SEN rising edge	38.4		ns

**Figure 11. Recommended Bus Sharing**



### Equivalent Circuit Model Description

The DTC Equivalent Circuit Model includes all parasitic elements and is accurate in both Series and Shunt configurations, reflecting physical circuit behavior accurately and providing very close correlation to measured data. It can easily be used in circuit simulation programs.

For  $V_P$  and  $V_M$  max operating limits, refer to Table 3.

Figure 12. Equivalent Circuit Model Schematic

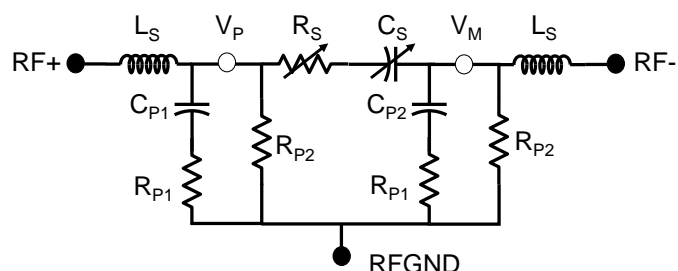


Table 7. Equivalent Circuit Model Parameters

Variable	Equation (state = 0, 1, 2...31)	Unit
C <sub>S</sub>	0.185*state + 1.6	pF
R <sub>S</sub>	20/(state+20/(state+0.7)) + 0.7	Ω
R <sub>P1</sub>	8+0.5*state	Ω
R <sub>P2</sub>	25000+3*state+3	Ω
C <sub>P1</sub>	-0.0061*state + 0.55	pF
C <sub>P2</sub>	0.0096*state + 0.61	pF
L <sub>S</sub>	0.35	nH

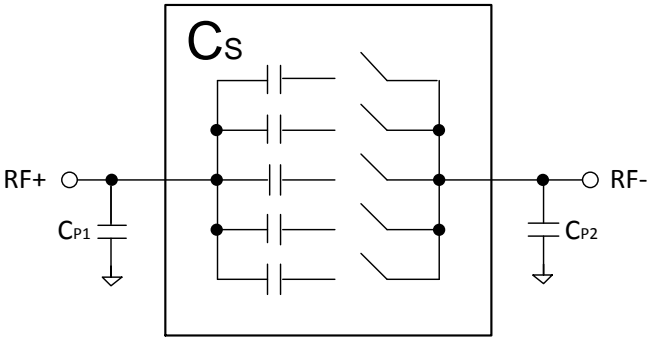
Table 8. Equivalent Circuit Data

State			DTC Core		Parasitic Elements	
Hex	Bin	Dec	C <sub>S</sub> [pF]	R <sub>S</sub> [Ω]	C <sub>P1</sub>	C <sub>P2</sub>
0x00	00000	0	1.60	1.40	0.55	0.61
0x01	00001	1	1.79	2.27	0.54	0.62
0x02	00010	2	1.97	2.83	0.54	0.63
0x03	00011	3	2.16	3.08	0.53	0.64
0x04	00100	4	2.34	3.12	0.53	0.65
0x05	00101	5	2.53	3.05	0.52	0.66
0x06	00110	6	2.71	2.93	0.51	0.67
0x07	00111	7	2.90	2.78	0.51	0.68
0x08	01000	8	3.08	2.64	0.50	0.69
0x09	01001	9	3.27	2.51	0.50	0.70
0x0A	01010	10	3.45	2.39	0.49	0.71
0x0B	01011	11	3.64	2.27	0.48	0.72
0x0C	01100	12	3.82	2.17	0.48	0.73
0x0D	01101	13	4.01	2.08	0.47	0.73
0x0E	01110	14	4.19	2.00	0.46	0.74
0x0F	01111	15	4.38	1.93	0.46	0.75
0x10	10000	16	4.56	1.86	0.45	0.76
0x11	10001	17	4.75	1.80	0.45	0.77
0x12	10010	18	4.93	1.75	0.44	0.78
0x13	10011	19	5.12	1.70	0.43	0.79
0x14	10100	20	5.30	1.65	0.43	0.80
0x15	10101	21	5.49	1.61	0.42	0.81
0x16	10110	22	5.67	1.57	0.42	0.82
0x17	10111	23	5.86	1.54	0.41	0.83
0x18	11000	24	6.04	1.51	0.40	0.84
0x19	11001	25	6.23	1.48	0.40	0.85
0x1A	11010	26	6.41	1.45	0.39	0.86
0x1B	11011	27	6.60	1.42	0.39	0.87
0x1C	11100	28	6.78	1.40	0.38	0.88
0x1D	11101	29	6.97	1.37	0.37	0.89
0x1E	11110	30	7.15	1.35	0.37	0.90
0x1F	11111	31	7.34	1.33	0.36	0.91

### Series Operation

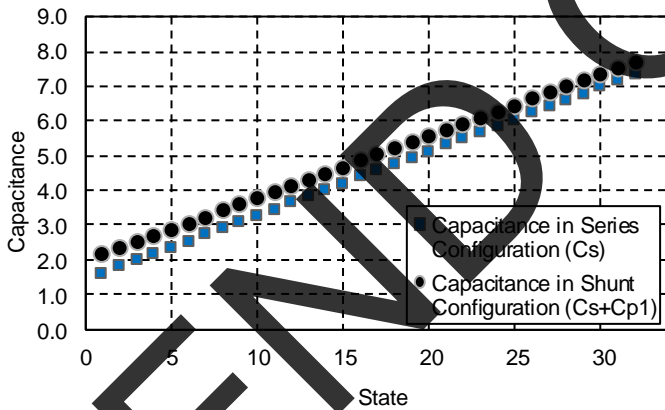
In Series configuration, the effective capacitance between RF+ and RF- ports is represented by  $C_s$  and tuning ratio as  $C_{Smax}/C_{Smin}$ .

**Figure 13. Effective Capacitance Diagram**



Shunt Configuration (looking into RF+ when RF- is grounded) will have higher total capacitance at RF+ due to parallel combination of  $C_s$  with parasitic capacitance  $C_{p1}$  ( $C_s + C_{p1}$ ), as demonstrated in Figure 14 and Table 9.

**Figure 14. Typical Capacitance vs. State**

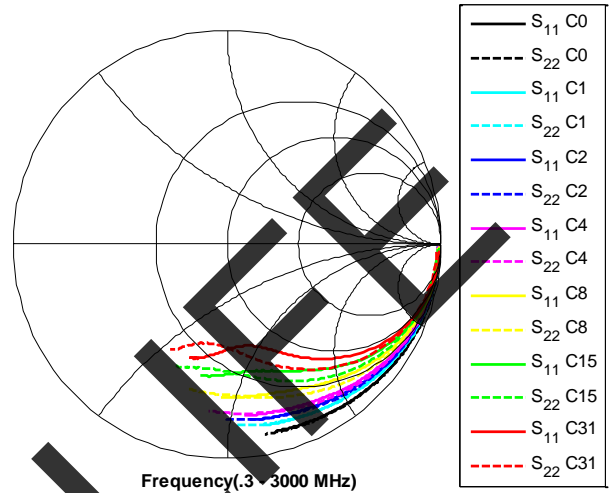


**Table 9. Effective Capacitance Summary**

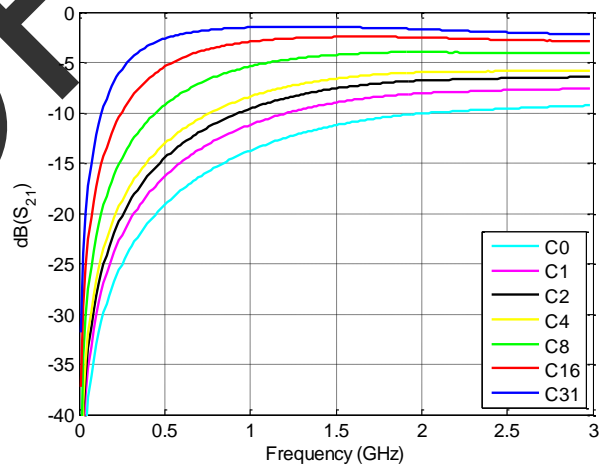
Configuration	Effective Capacitance	$C_{min}$ (state 0)	$C_{max}$ (state 31)	Tuning Ratio
Series (RF+ to RF-)	$C_s$	1.60	7.34	4.59:1
Shunt (RF+ to GND)	$C_s + C_{p1}$	2.15	7.7	3.6:1

$S_{11}$  and  $S_{21}$  for series configuration is illustrated in Figures 15 and 16.  $S_{21}$  includes mismatch and dissipative losses and is not indicative of tuning network loss. Equivalent Circuit Model can be used for simulation of tuning network loss.

**Figure 15. Measured Series  $S_{11}/S_{22}$  (major states)**



**Figure 16. Measured Series  $S_{21}$  vs. Frequency (major states)**

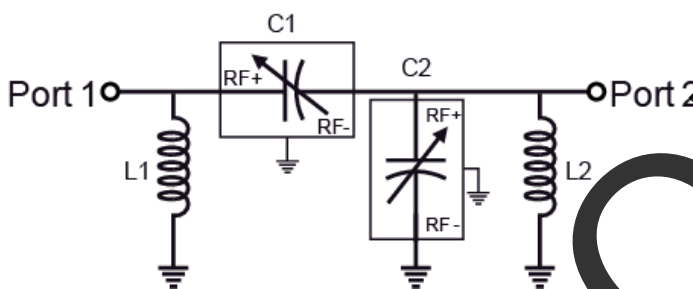


When the DTC is used as a part of a reactive network, impedance transformation may cause the internal RF voltages ( $V_P$  and  $V_M$  in Figure 12) to exceed peak operating RF voltage. The complete RF circuit must be simulated using actual input power and load conditions to ensure neither  $V_P$  nor  $V_M$  exceeds 30 Vpk.

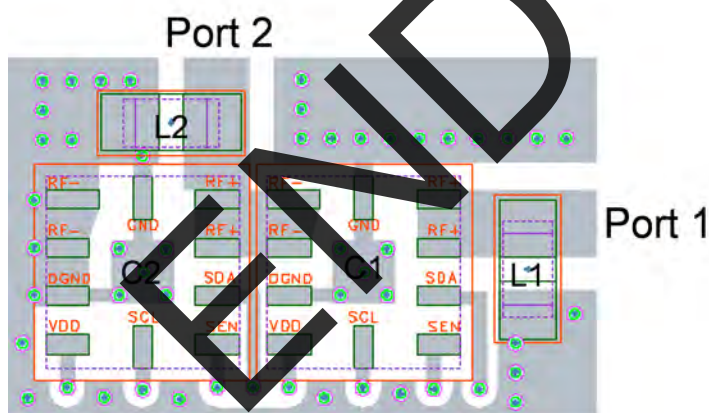
### Layout Recommendations

For optimal results, place a ground fill directly under the DTC package on the PCB. Layout isolation is desired between all control and RF lines. When using the DTC in a shunt configuration, it is important to make sure the RF-pin is solidly grounded to a filled ground plane. Ground traces should be as short as possible to minimize inductance. A continuous ground plane is preferred on the top layer of the PCB. When multiple DTCs are used together, the physical distance between them should be minimized and the connection should be as wide as possible to minimize series parasitic inductance.

**Figure 17. Recommended Schematic of Multiple DTCs**



**Figure 18. Recommended Layout of Multiple DTCs**

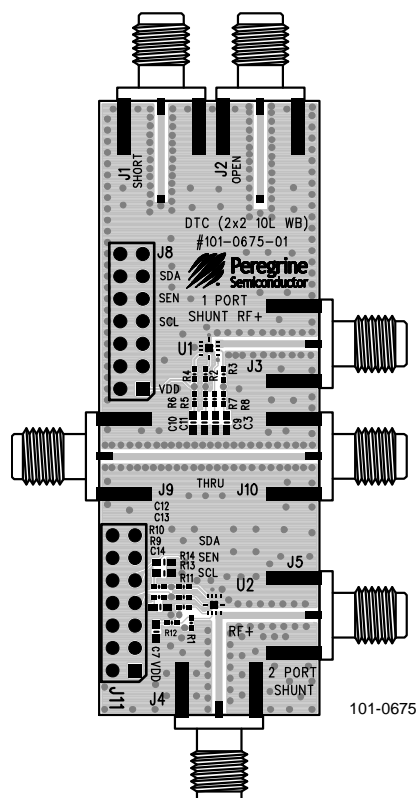


### Evaluation Board

The 101-0675 Evaluation Board (EVB) was designed for accurate measurement of the DTC impedance and loss. Two configurations are available: 1 Port Shunt (J3) and 2 Port Shunt (J4, J5). Three calibration standards are provided. The open (J2) and short (J1) standards (104 ps delay) are used for performing port extensions and accounting for electrical length and transmission line loss. The Thru (J9, J10) standard can be used to estimate PCB transmission line losses for scalar de-embedding of the 2 Port Series configuration (J4, J5).

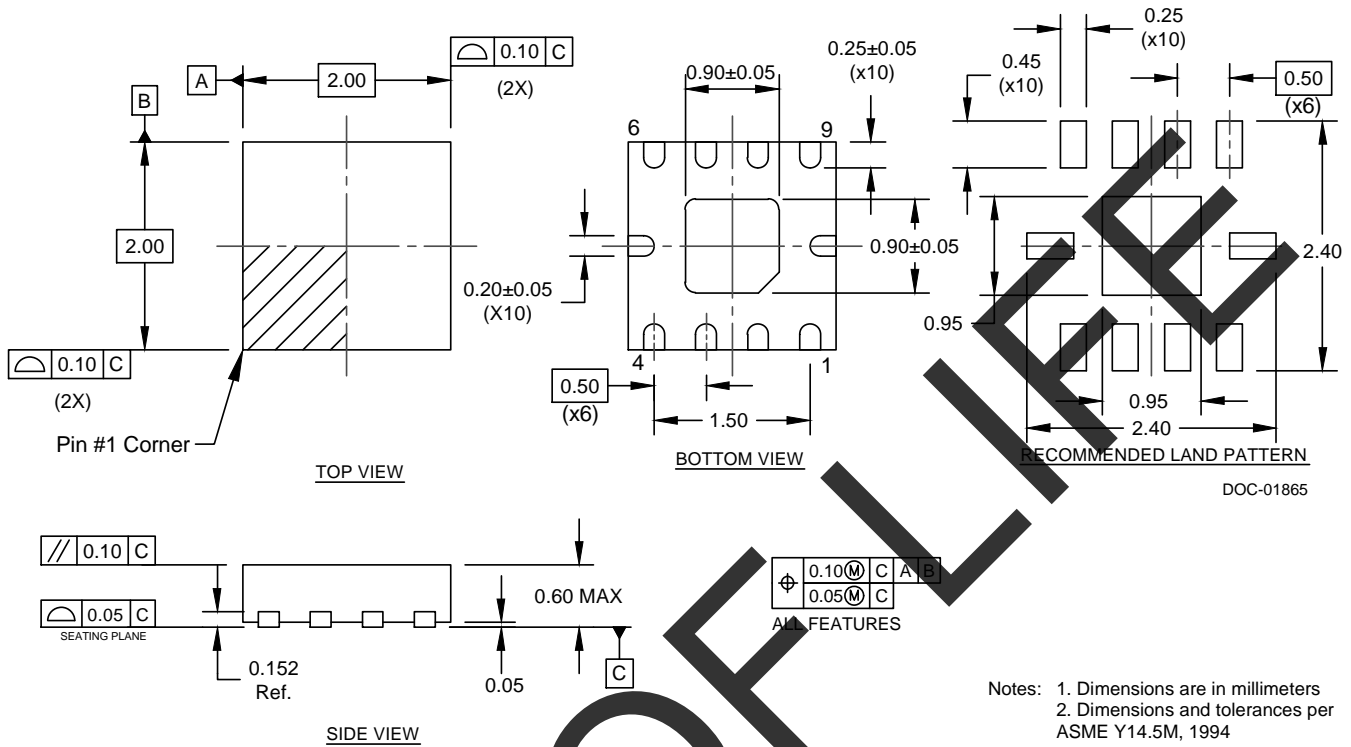
The board consists of a 4 layer stack with 2 outer layers made of Rogers 4350B ( $\epsilon_r = 3.48$ ) and 2 inner layers of FR4 ( $\epsilon_r = 4.80$ ). The total thickness of this board is 62 mils (1.57 mm). The inner layers provide a ground plane for the transmission lines. Each transmission line is designed using a coplanar waveguide with ground plane (CPWG) model using a tracewidth of 32 mils (0.813 mm), gap of 15 mils (0.381 mm), and a metal thickness of 1.4 mils (0.051 mm).

**Figure 19. Evaluation Board Layout**

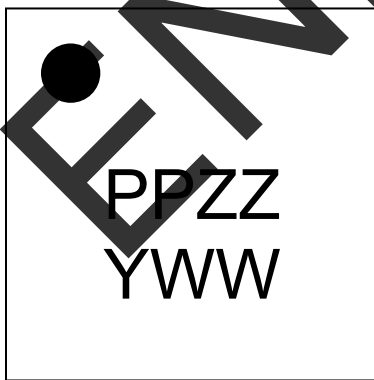




**Figure 20. Package Drawing**  
10-lead 2 x 2 x 0.55 mm QFN



**Figure 21. Top Marking Specifications**



17-0112

Marking Spec Symbol	Package Marking	Definition
PP	DK*	Part number marking for PE64908
ZZ	00-99	Last two digits of lot code
Y	0-9	Last digit of year, starting from 2009 (0 for 2010, 1 for 2011, etc)
WW	01-53	Work week

\* Note: (PP), the package marking specific to the PE64906, is shown in the figure instead of the standard Peregrine package marking symbol (P)

Figure 22. Tape and Reel Specifications

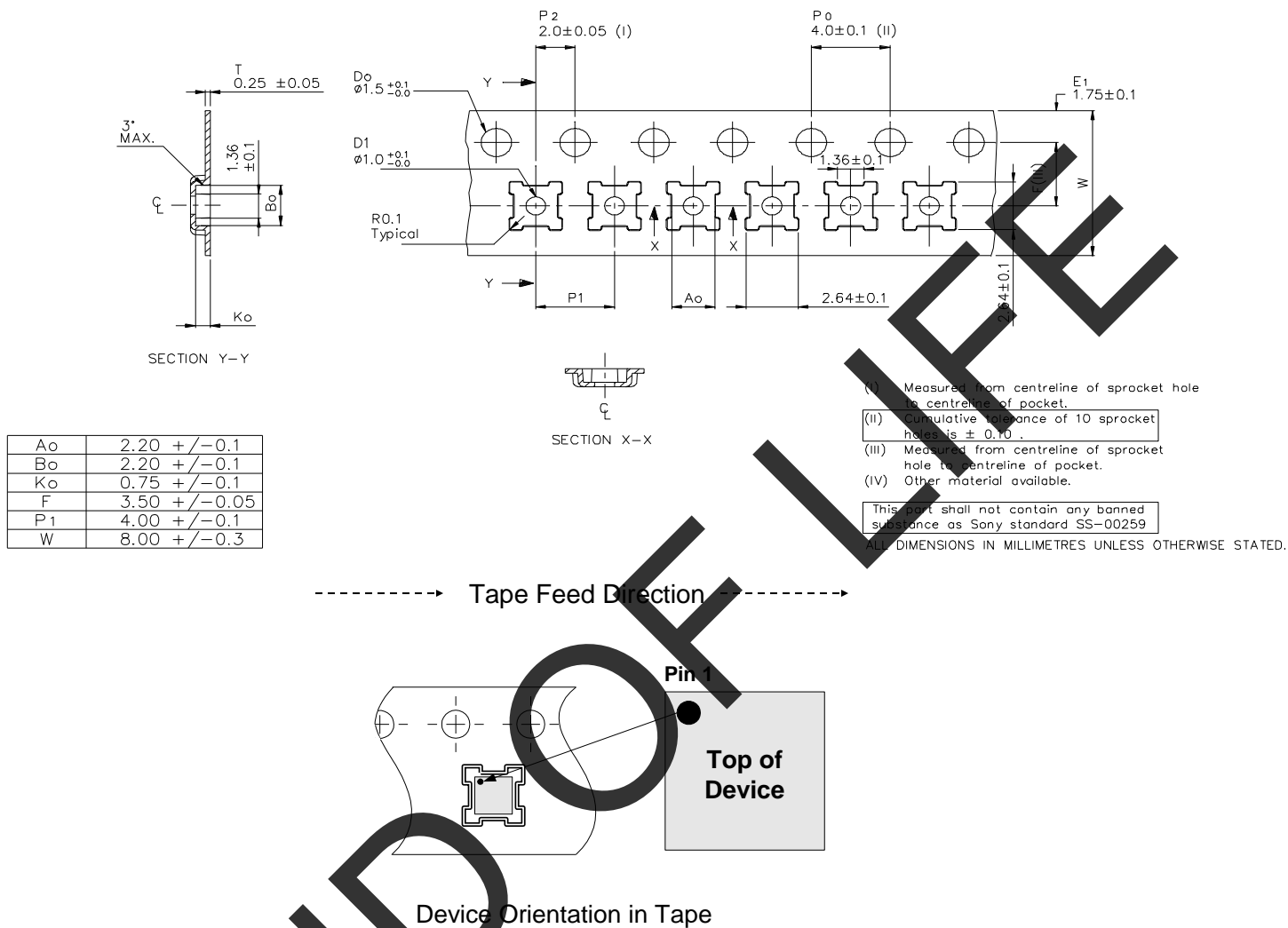


Table 10. Ordering Information

Order Code	Description	Package	Shipping Method
PE64908MLAA-Z	PE64908 DTC	10-lead 2x2 mm QFN	3,000 units/T&R
EK64908-11	PE64908 Evaluation kit	Evaluation kit	1 set/box

Sales Contact and Information

For sales and contact information please visit [www.psemi.com](http://www.psemi.com).

**Advance Information:** The product is in a formative or design stage. The datasheet contains design target specifications for product development. Specifications and features may change in any manner without notice.  
**Preliminary Specification:** The datasheet contains preliminary data. Additional data may be added at a later date. Peregrine reserves the right to change specifications at any time without notice in order to supply the best possible product.  
**Product Specification:** The datasheet contains final data. In the event Peregrine decides to change the specifications, Peregrine will notify customers of the intended changes by issuing a CNF (Customer Notification Form).  
 The information in this datasheet is believed to be reliable. However, Peregrine assumes no liability for the use of this information. Use shall be entirely at the user's own risk.

No patent rights or licenses to any circuits described in this datasheet are implied or granted to any third party. Peregrine's products are not designed or intended for use in devices or systems intended for surgical implant, or in other applications intended to support or sustain life, or in any application in which the failure of the Peregrine product could create a situation in which personal injury or death might occur. Peregrine assumes no liability for damages, including consequential or incidental damages, arising out of the use of its products in such applications.  
 The Peregrine name, logo, UltraCMOS and UTSi are registered trademarks and HaRP, MultiSwitch and DuNE are trademarks of Peregrine Semiconductor Corp. Peregrine products are protected under one or more of the following U.S. Patents: <http://patents.psemi.com>.

## X-ON Electronics

Largest Supplier of Electrical and Electronic Components

*Click to view similar products for [Interface - Specialized category](#):*

*Click to view products by [pSemi manufacturer](#):*

Other Similar products are found below :

[CY7C910-51LMB](#) [MC33689DPEWR2](#) [MC33975TEKR2](#) [MEC1632-AUE](#) [MC33978AEK](#) [NVT4555UKZ](#) [TJA1081TS,112](#) [RKSAS4](#)  
[HMC677G32](#) [LPC47N207-JV](#) [FTP-637DSL633R](#) [MAX7348AEP+](#) [SM712GX04LF04-BA](#) [DS2413P+T&R](#) [NCN5193MNTWG](#)  
[MC34978AEK](#) [MC33689DPEW](#) [MC33889BPEG](#) [NCV7381DP0R2G](#) [PCA9704PWJ](#) [S6BT112A01SSBB202](#) [MAX7347AEE+](#) [DS8113-](#)  
[RNG+T&R](#) [DS8024-RJX+T&R](#) [NCN5192MNRG](#) [DS8023-RRX+T&R](#) [DS8024-RRX+T&R](#) [ST8034HCQR](#) [XP71055](#)  
[TC7PCI3212MT,LF\(S](#) [ASI4UE-F-G1-ST](#) [HOA6241-001](#) [MEC1310-NU](#) [SC74HC4066ADTR2G](#) [TDA8035HNC1S1QL](#) [TNY380PN](#)  
[RMT3PB080](#) [AS3935-BQFT](#) [0714300268](#) [MAX9924UAUB/V+](#) [MAX3120CUA+](#) [MAX3171CAI](#) [NCN8025MTTBG](#) [DS8023-RRX](#)  
[DS2406P+T&R](#) [DS8007-ENG+](#) [DS8007A-EAG+](#) [DS2482X-101T](#) [DS1886T+](#) [DG407AK/883B](#)