

## Fast CMOS Clock Driver/Buffer

### Features

- Extremely low output skew: 0.5ns
- Monitor output pin
- Clock busing with Hi-Z state control
- TTL input and CMOS output compatible
- Extremely low static power (1mW, typ.)
- Hysteresis on all inputs
- Device models available on request
- Industrial Operation at -40°C to +85°C
- Packaging (Pb-free & Green):
  - 20-pin 209-mil wide SSOP (H)
  - 20-pin 300-mil wide SOIC (S)
  - 20-pin 150-mil wide QSOP (Q)

### Description

Pericom Semiconductor's PI49FCT805T and PI49FCT2805T are non-inverting clock drivers. Each clock driver consists of two banks of drivers, driving five outputs each from a standard TTL-compatible CMOS input.

The PI49FCT2805T features a 25-Ohm on-chip resistor for lower noise.

### Block Diagram

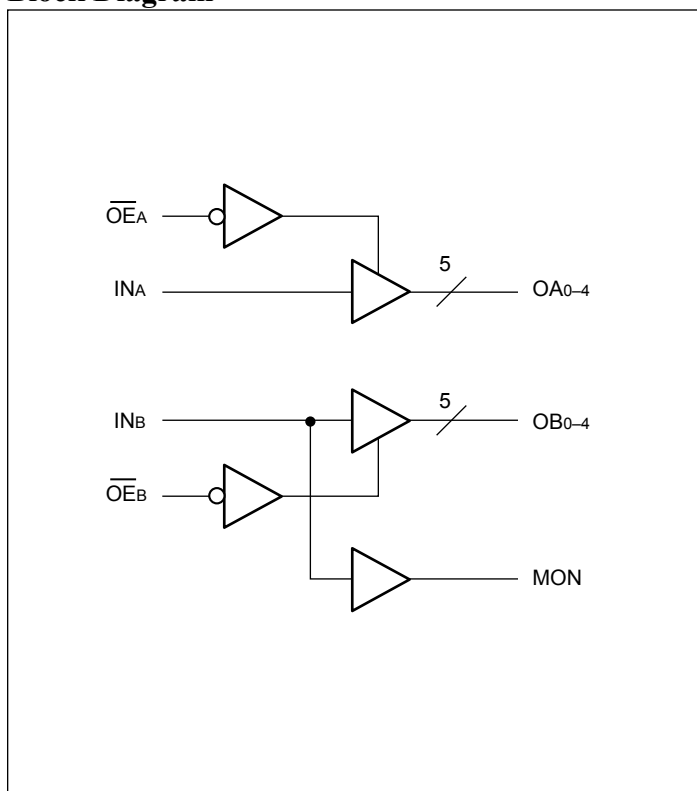

### Pin Configuration

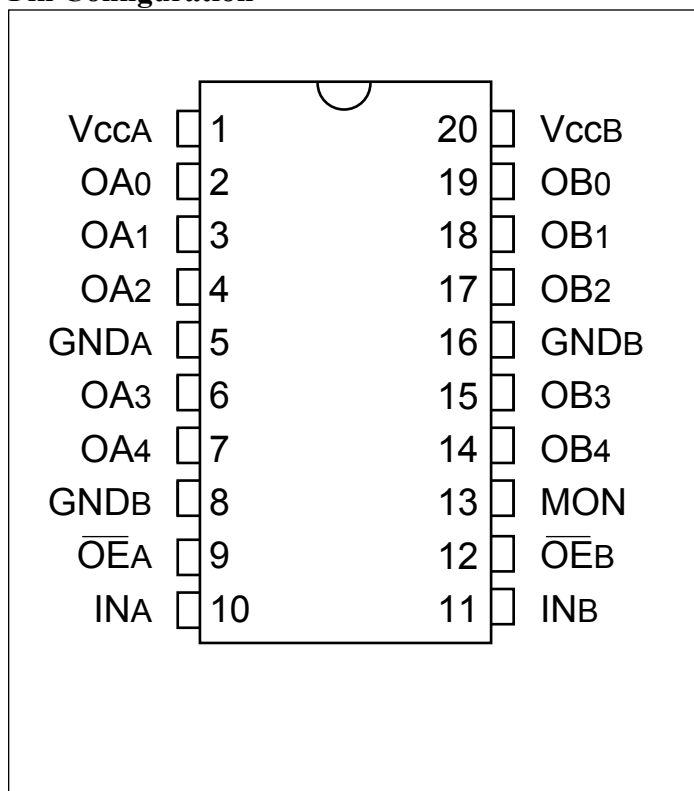

### Maximum Ratings

(Above which the useful life may be impaired. For user guidelines, not tested.)

Storage Temperature .....	-65°C to +150°C
Ambient Temperature with Power Applied .....	-40°C to +85°C
Supply Voltage to Ground Potential (Inputs & Vcc Only) .....	-0.5V to +7.0V
Supply Voltage to Ground Potential (Outputs & D/O Only) .....	-0.5V to +7.0V
DC Input Voltage .....	-0.5V to +7.0V
DC Output Current .....	120mA
Power Dissipation .....	0.5W

**Note:**

Stresses greater than those listed under MAXIMUM RATINGS may cause permanent damage to the device. This is a stress rating only and functional operation of the device at these or any other conditions above those indicated in the operational sections of this specification is not implied. Exposure to absolute maximum rating conditions for extended periods may affect reliability.

### DC Electrical Characteristics (Over the Operating Range, TA = -40°C to +85°C, VCC = 5.0V ± 5%)

Param-eters	Description	Test Conditions <sup>(1)</sup>		Min.	Typ(2)	Max.	Units
Voh	Output HIGH Voltage	Vcc = Min., Vin = Vih or Vil	Ioh = -24.0mA	2.4	3.3		V
Vol	Output LOW Current	Vcc = Min., Vin = Vih or Vil	Iol = 64mA		0.3	0.55	V
			Iol = 12mA (25Ω)		0.3	0.50	V
Vih	Input HIGH Voltage	Guaranteed Logic HIGH Level		2.0			V
Vil	Input LOW Voltage	Guaranteed Logic LOW Level				0.8	V
Iih	Input HIGH Current	Vcc = Max.	Vin = Vcc			1	μA
Iil	Input LOW Current	Vcc = Max.	Vin = GND			-1	μA
Iozh	High Impedance	Vcc = Max.	Vout = Vcc			1	μA
Iozl	Output Current		Vout = GND			-1	μA
Ii	Input HIGH Current	Vcc = Max., Vin = Vcc (Max.)				20	μA
Vik	Clamp Diode Voltage	Vcc = Min., Iin = -18mA			-0.7	-1.2	V
Ios	Short Circuit Current	Vcc = Max.(3), Vout = GND		-60	-120	-225	mA
Vh	Input Hysteresis	Vcc = 5 V			200		mV

## Capacitance

Parameters	Description	Test Conditions	Typ	Max.	Units
C <sub>IN</sub>	Input Capacitance	V <sub>IN</sub> = 0V	6	10	pF
C <sub>OUT</sub>	Output Capacitance	V <sub>OUT</sub> = 0V	8	12	pF

### Notes:

1. For Max. or Min. conditions, use appropriate value specified under Electrical Characteristics for the applicable device type.
2. Typical values are at VCC = 5.0V, +25°C ambient and maximum loading.
3. Not more than one output should be shorted at one time. Duration of the test should not exceed one second.
4. This parameter is determined by device characterization but is not production tested.

## Power Supply Characteristics

Parameters	Description	Test Conditions		Min	Typ	Max.	Units
I <sub>cc</sub>	Quiescent Power Supply Current	V <sub>cc</sub> = Max.	V <sub>in</sub> = GND or V <sub>cc</sub>		3	30	μA
D <sub>Icc</sub>	Supply Current per Input @ TTL HIGH	V <sub>cc</sub> = Max.	V <sub>in</sub> = 3.4V(3)		0.5	2.0	mA
I <sub>ccd</sub>	Supply Current per Input per MHz(4)	V <sub>cc</sub> = Max., Outputs Open, OE <sub>a</sub> = OE <sub>b</sub> = GND, Per Output Toggling, 50% Duty Cycle	V <sub>in</sub> = V <sub>cc</sub> , V <sub>in</sub> = GND		0.15	0.25	mA/MHz
I <sub>c</sub>	Total Power Supply Current	V <sub>cc</sub> = Max., Outputs Open f <sub>i</sub> = 10MHz 50% Duty Cycle OE <sub>A</sub> = OE <sub>B</sub> = GND	V <sub>in</sub> = V <sub>cc</sub> , V <sub>in</sub> = GND		7.7	14.0 <sup>5</sup>	mA
					8.0	15.0 <sup>5</sup>	
		Five Outputs Toggling V <sub>cc</sub> = Max., Outputs Open f <sub>i</sub> = 10MHz 50% Duty Cycle OE <sub>A</sub> = OE <sub>B</sub> = GND	V <sub>in</sub> = 3.4V, V <sub>in</sub> = GND		4.3	8.4 <sup>5</sup>	
					4.8	10.4 <sup>5</sup>	

### Notes:

1. For Max. or Min. conditions, use appropriate value specified under Electrical Characteristics for the applicable device.
2. Typical values are at V<sub>cc</sub> = 5.0V, +25°C ambient.
3. Per TTL driven input (V<sub>in</sub> = 3.4V); all other inputs at V<sub>cc</sub> or GND.
4. This parameter is not directly testable, but is derived for use in Total Power Supply Calculations.
5. Values for these conditions are examples of the I<sub>cc</sub> formula. These limits are guaranteed but not tested.
6. I<sub>c</sub> = I<sub>quiescent</sub> + I<sub>inputs</sub> + I<sub>dynamic</sub>  
 $I_c = I_{cc} + D_{Icc} DhNt + I_{ccd} (f_{cp}/2 + f_i N_i)$   
 I<sub>cc</sub> = Quiescent Current  
 D<sub>Icc</sub> = Power Supply Current for a TTL High Input (V<sub>in</sub> = 3.4V)  
 Dh = Duty Cycle for TTL Inputs High  
 Nt = Number of TTL Inputs at Dh  
 I<sub>ccd</sub> = Dynamic Current Caused by an Input Transition Pair (HLH or LHL)  
 f<sub>cp</sub> = Clock Frequency for Register Devices (Zero for Non-Register Devices)  
 f<sub>i</sub> = Input Frequency  
 N<sub>i</sub> = Number of Inputs at f<sub>i</sub>  
 All currents are in milliamps and all frequencies are in megahertz.

### Switching Characteristics over Operating Range

Parameters	Description	Test Conditions <sup>(1)</sup>	805T/2805T		805AT		805BT		805CT		Units
			Com.		Com.		Com.		Com.		
			Min.	Max.	Min.	Max.	Min.	Max.	Min.	Max.	
t <sub>PLH</sub> t <sub>PHL</sub>	Propagation Delay IN <sub>A</sub> to OA <sub>N</sub> , IN <sub>B</sub> to OB <sub>N</sub>	CL = 50pF RL = 500Ω	1.5	6.5	1.5	5.8	1.5	5.0	1.5	4.5	ns
t <sub>PZH</sub> t <sub>PZL</sub>	Output Enable Time OE <sub>A</sub> to OA <sub>N</sub> , OE <sub>B</sub> to OB <sub>N</sub>		1.5	8.0	1.5	8.0	1.5	8.5	1.5	6.2	
t <sub>PHZ</sub> t <sub>PLZ</sub>	Output Disable Time <sup>(4)</sup> OE <sub>A</sub> to OA <sub>N</sub> , OE <sub>B</sub> to OB <sub>N</sub>		1.5	7.0	1.5	7.0	1.5	6.0	1.5	5.0	
t <sub>SKEW(o)</sub> <sup>(3)</sup>	Skew twx two outputs of the same package (same transition)		–	0.7	–	0.5	–	0.4	–	0.4	
t <sub>SKEW(p)</sub> <sup>(3)</sup>	Skew twx two opposite transition (t <sub>PHL</sub> - t <sub>PLH</sub> ) of same output		–	1.0	–	0.7	–	0.5	–	0.5	
t <sub>SKEW(t)</sub> <sup>(3)</sup>	Skew twx two outputs of the different package at same temperature (same transition)		–	1.5	–	1.0	–	1.0	–	1.0	

**Notes:**

1. See test circuit and wave forms.
2. Minimum limits are guaranteed but not tested on Propagation Delays.
3. Skew measured at worse cast temperature (max. temp).
4. This parameter is guaranteed but not production tested.

#### Tests Circuits For All Outputs(1)

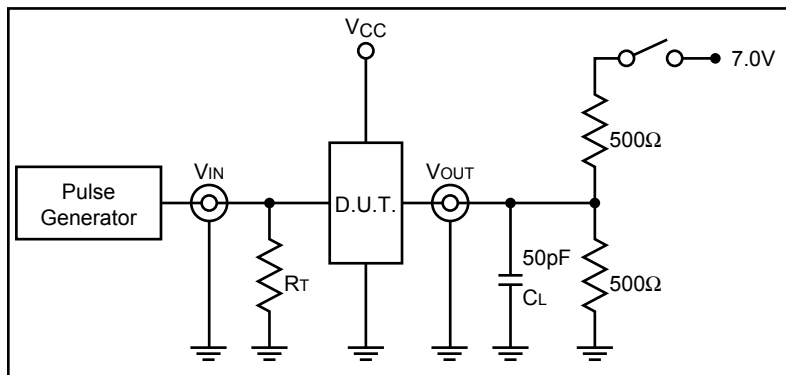

#### Switch Position

Test	Switch
Open Drain Enable LOW Disable LOW	Closed
All other inputs	Open

**Definitions:**

CL = Load capacitance: includes jig and probe capacitance.  
RT = Termination resistance: should be equal to ZOUT of the Pulse Generator.

## Switching Waveforms

Propagation Delay

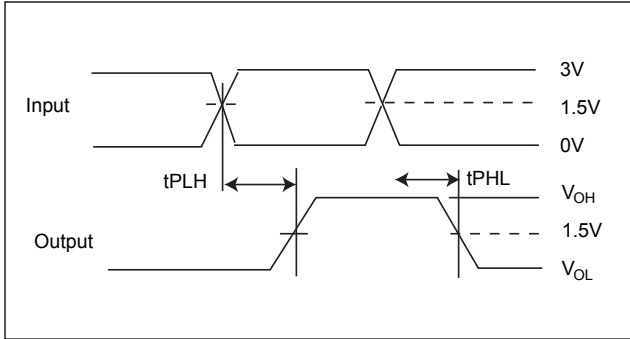

Output Skew – tsk(o)

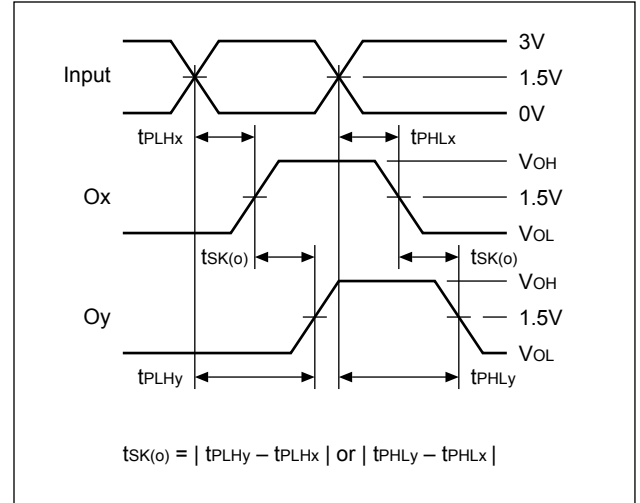

Enable and Disable Times

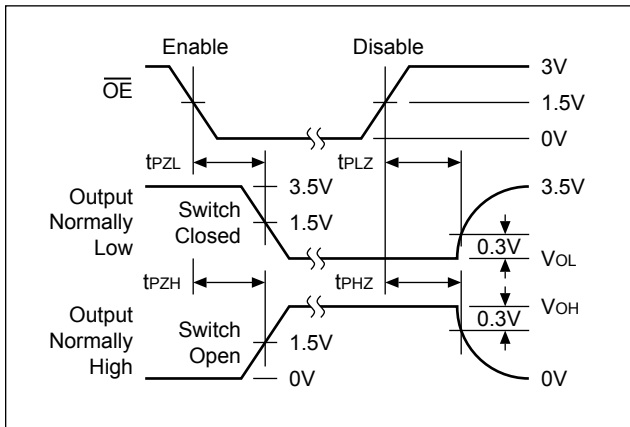

Pulse Skew – tsk(p)

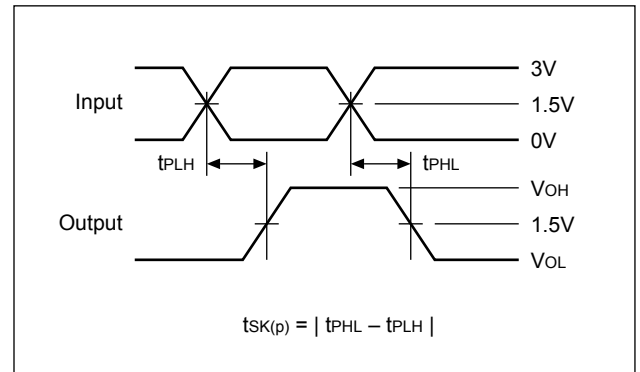

Package Skew – tsk(t)

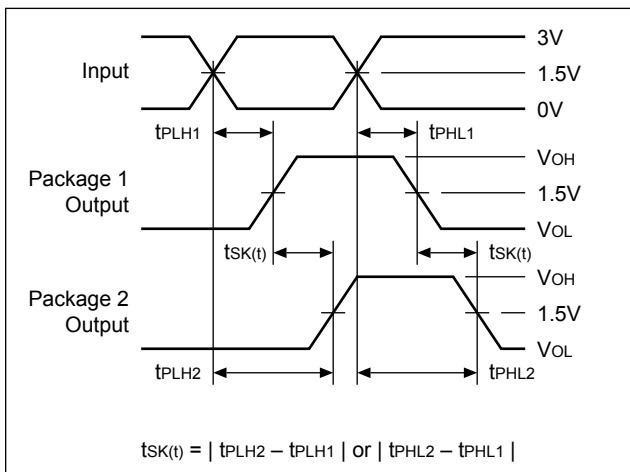

**Packaging Mechanical: 20-pin SSOP (H20)**

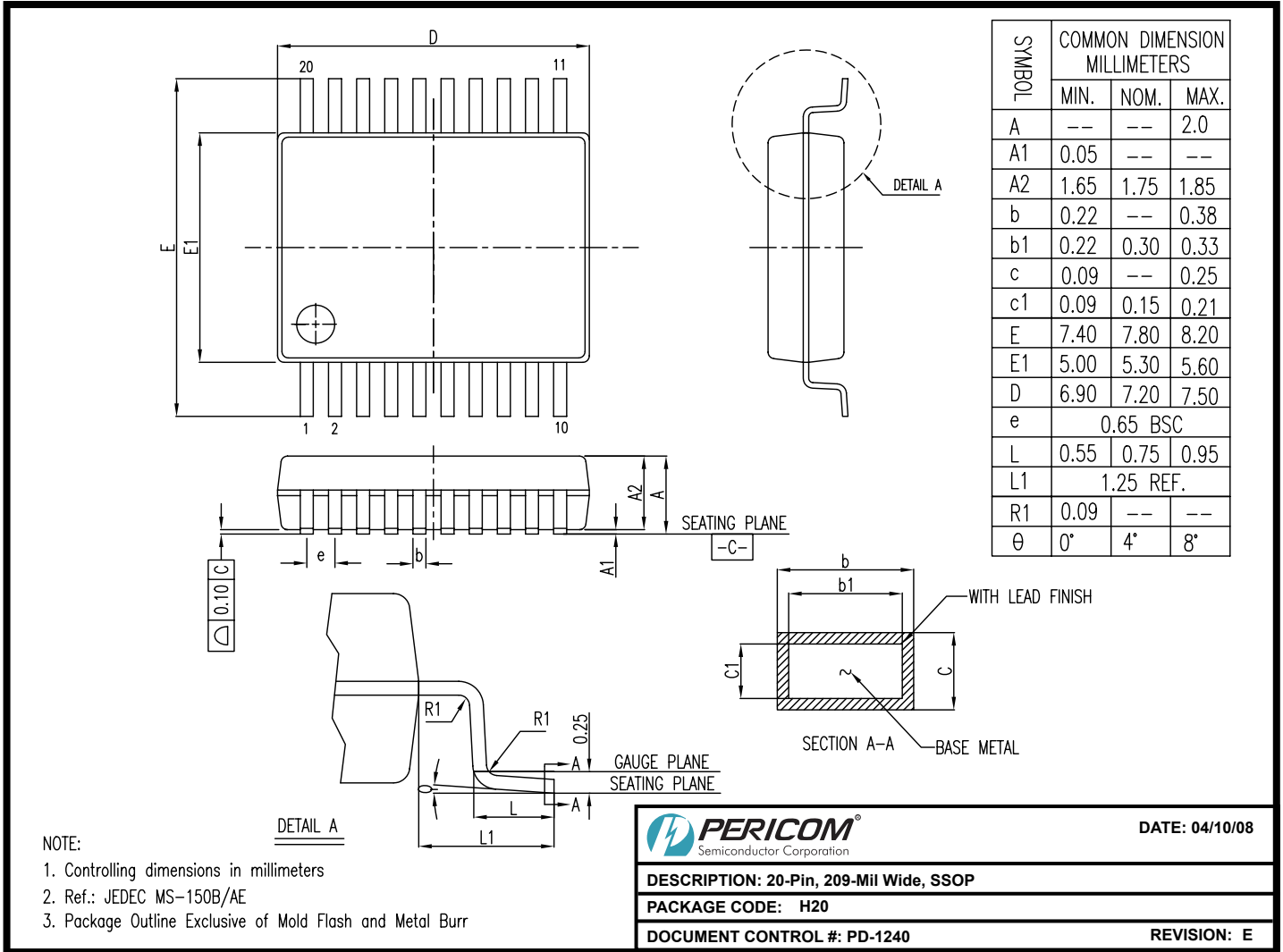

Note:

- For latest package info, please check: <http://www.pericom.com/products/packaging/mechanicals.php>

**Packaging Mechanical: 20-pin QSOP (Q20)**

DOCUMENT CONTROL NO.  
 PD - 1202

REVISION: H  
 DATE: 10/22/07

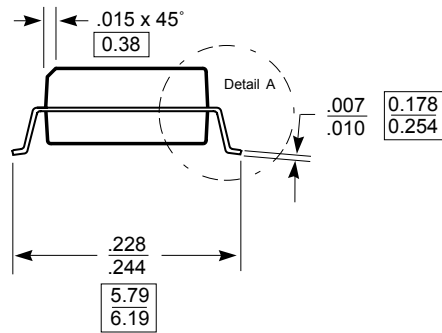
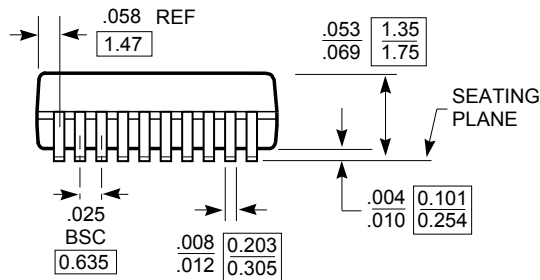
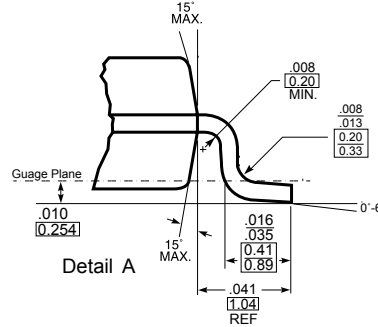
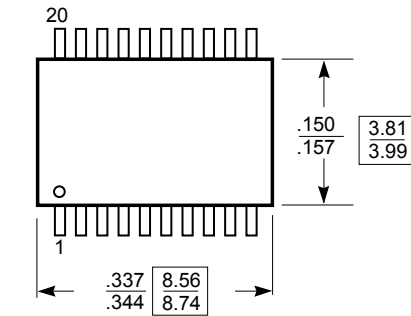

X.XX DENOTES DIMENSIONS  
 X.XX IN MILLIMETERS

- Note:
- 1) Controlling dimensions in inches.
  - 2) Ref: JEDEC MO-137B/AD
  - 3) Dimensions do not include mold flash, protrusions or gate burrs



Pericom Semiconductor Corporation  
 3545 N. 1st Street, San Jose, CA 95134  
 1-800-435-2335 • www.pericom.com

DESCRIPTION: 20-Pin, 150-Mil Wide, QSOP

PACKAGE CODE: Q

Note:

- For latest package info, please check: <http://www.pericom.com/products/packaging/mechanicals.php>

**Packaging Mechanical: 20-pin SPIC (S20)**

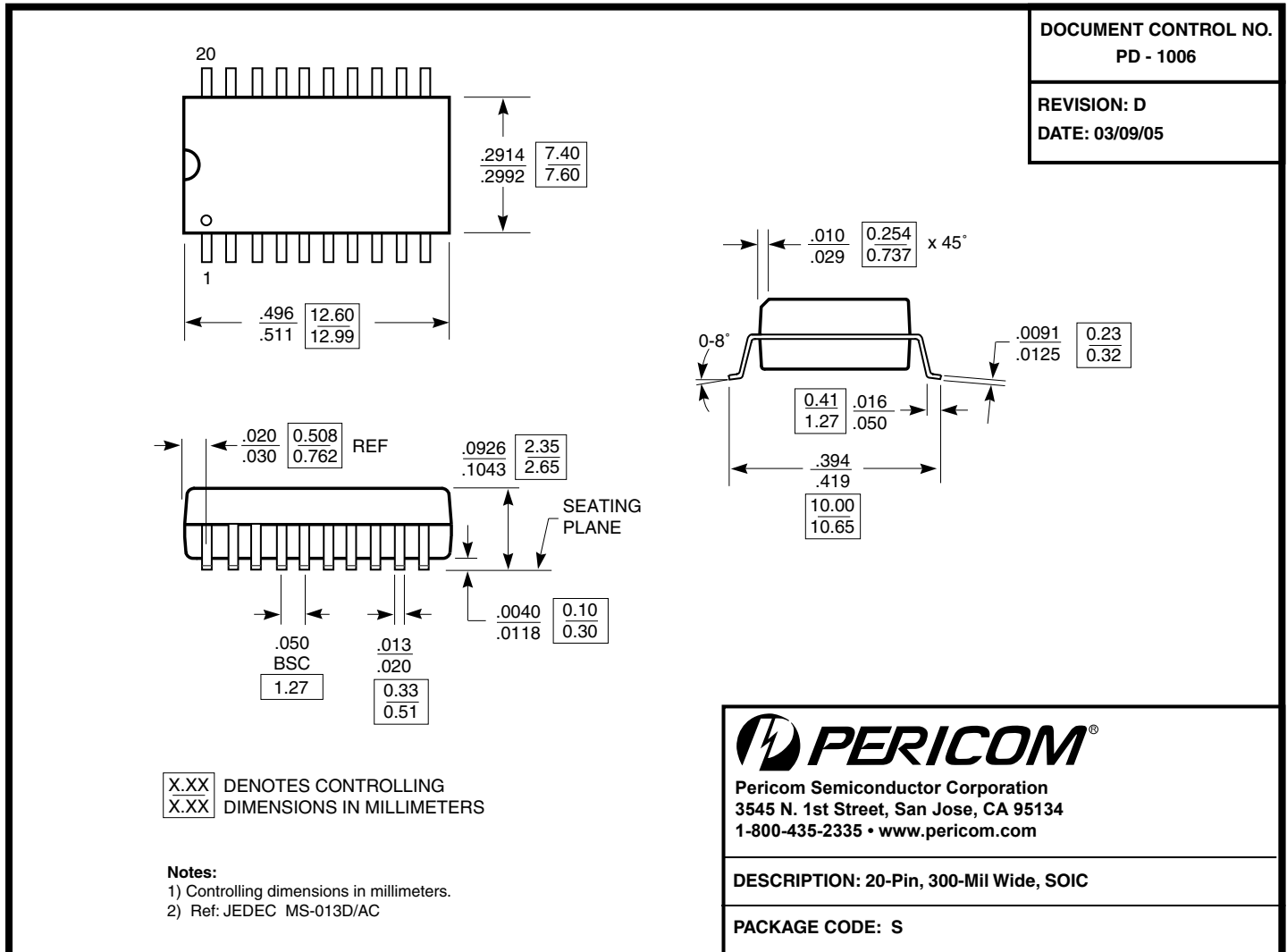

Note:

- For latest package info, please check: <http://www.pericom.com/products/packaging/mechanicals.php>



**Ordering Information<sup>(1-3)</sup>**

Ordering Code	Package Code	Speed Grade	Package Type
PI49FCT805TQE	Q	Blank	Pb-free & Green, 20-pin 150-mil QSOP
PI49FCT805ATSE	S	A	Pb-free & Green, 20pin 300-mil SOIC
PI49FCT805CTHE	H	C	Pb-free & Green, 20-pin 209-mil SOIC
PI49FCT805CTQE	Q	C	Pb-free & Green, 20-pin 150-mil QSOP

**Notes:**

1. Thermal characteristics can be found on the company web site at [www.pericom.com/packaging/](http://www.pericom.com/packaging/)
2. E = Pb-free and Green
3. Adding an X suffix = Tape/Reel

**Ordering Information for PI49FCT2805T**

Ordering Code	Package Code	Speed Grade	Package Type
PI49FCT2805TSE	S	Blank	Pb-free & Green, 20-pin 300-mil SOIC
PI49FCT2805TQE	Q	Blank	Pb-free & Green, 20-pin 150-mil QSOP

**Notes:**

1. Thermal characteristics can be found on the company web site at [www.pericom.com/packaging/](http://www.pericom.com/packaging/)
2. E = Pb-free and Green
3. Adding an X suffix = Tape/Reel

## X-ON Electronics

Largest Supplier of Electrical and Electronic Components

*Click to view similar products for [Clock Buffer](#) category:*

*Click to view products by [Pericom](#) manufacturer:*

Other Similar products are found below :

[PL133-27GI](#) [9DBV0541AKLF](#) [9DBV0941AKLF](#) [MPC962309EJ-1H](#) [NB3M8304CDG](#) [NB4N121KMNG](#) [NB7VQ58MMNG](#) [P5P2305AF-1H08SR](#) [8T39S11ANLGI](#) [8T73S1802NLGI](#) [9DBV0941AKILF](#) [MC10E111FNG](#) [MK2308S-1HILF](#) [5PB1216NDGK](#) [6V31024NLG](#) [P5I2305AF-1H08SR](#) [PL133-27GI-R](#) [9DBV0941AKILFT](#) [NB3L02FCT2G](#) [NB3L03FCT2G](#) [NB7VQ58MMNHTBG](#) [ZL40203LDG1](#) [ZL40200LDG1](#) [9DMV0141AKILFT](#) [ZL40205LDG1](#) [ZL40212LDG1](#) [ZL40201LDG1](#) [9DBV0541AKILF](#) [PI49FCT32807QE](#) [552-02SPGGI](#) [9FG1200DF-1LF](#) [MDB1900ZCQY](#) [9ZXL1530DKILF](#) [8SLVP1102ANLGI/W](#) [ZL40223LDG1](#) [5PB1203NTGK8](#) [9FG1001BGLF](#) [MDB1900ZBQY](#) [5PB1214CMGK](#) [ZL40202LDG1](#) [8L30205NLGI8](#) [5PB1204CMGK](#) [5PB1214CMGK8](#) [5PB1203NTGK](#) [5PB1206NDGK](#) [PI49FCT20802QE](#) [MAX9317AECJ+](#) [SL2305SC-1T](#) [PI6C10810HE](#) [5P1103A517NLGI](#)