

16-Bit 1.5-2.5V to 3.3V Level Shifting Transceiver with 3-State Outputs

Features

- PI74AVC164245LA is designed for low voltage operation: 1.5V - 2.5V to 3.3V
- Industrial operation at -40°C to +85°C
- Packag (Pb-free & Green available):
 - 48-pin plastic 240-mil TSSOP (A)
 - 48-pin plastic 173-mil TVSOP (K)

Description

Pericom Semiconductor's PI74AVC164245LA, a 16-bit (dual-octal) noninverting bus transceiver, contains two separate supply rails: B port (V_{CCB}), set at 3.3V, and A port (V_{CCA}), set to operate at 1.5-2.5V. This arrangement permits translation from a 1.5-2.5V to 3.3V environment and vice versa. The control pins, OE and DIR are controlled by V_{CCB}.

Truth Table (each 8-bit section)

Inputs		Operation
\overline{OE}	DIR	
L	L	B data to A bus
L	H	A data to B bus
H	X	Isolation

The PI74AVC164245LA is designed for asynchronous communication between data buses.

To ensure the high impedance state during power up or power down, the output-enable (OE) input should be tied to V_{CC} through a pullup resistor: the minimum value of the resistor is determined by the current-sinking capability of the driver.

Block Diagram

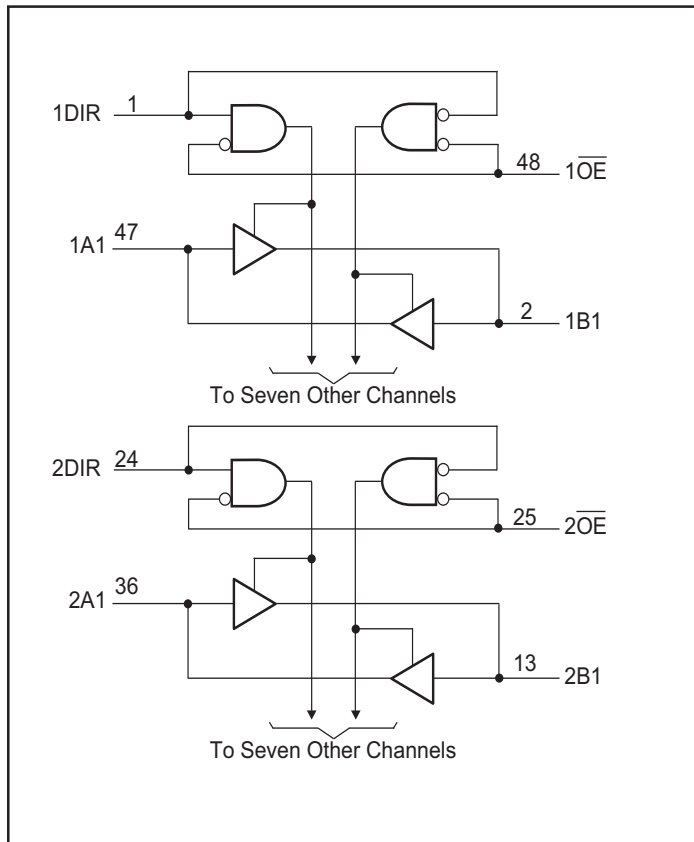

Pin Configuration

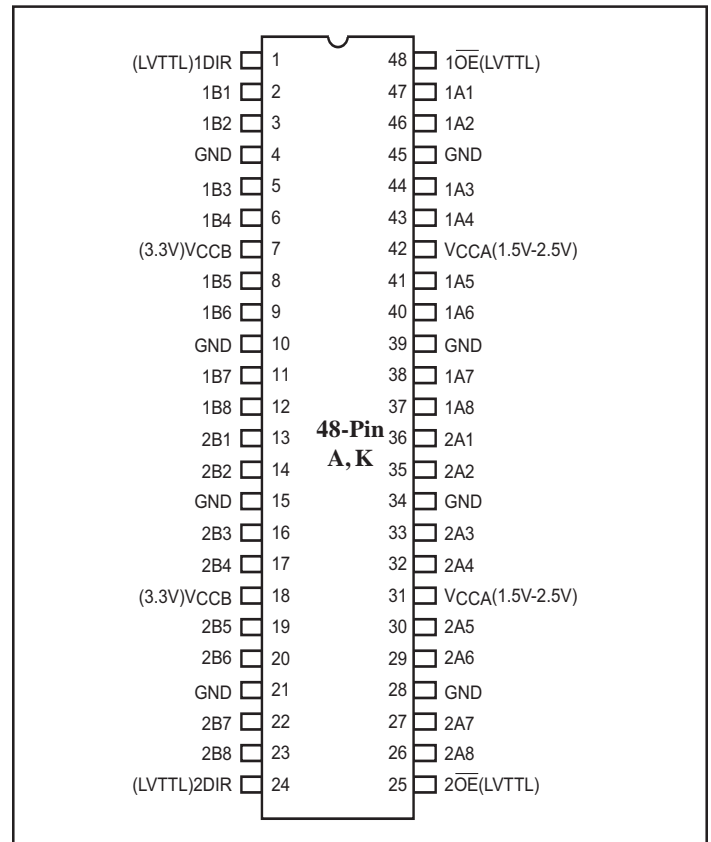

Maximum Ratings

(Absolute maximum ratings over operating free-air temperature range from V_{CCB} at 3.3V & V_{CCA} at 1.5 - 2.5V, unless otherwise noted)

Supply voltage range: V_{CCA} -0.5V to 3.8V	Continuous output current, I_O $\pm 50\text{mA}$
V_{CCB} -0.5V to 4.6V	Continuous current through each V_{CC} or GND $\pm 100\text{mA}$
Input Voltage Range, V_I Except I/O ports ⁽¹⁾ -0.5V to 4.6V	Package thermal impedance, θ_{JA} ⁽³⁾ : A package 89°C/W
I/O port A ⁽²⁾ ... -0.5V to $V_{CCA}+0.5\text{V}$	K package 58°C/W
I/O port B ⁽¹⁾ -0.5V to $V_{CCB}+0.5\text{V}$	V package 94°C/W
Input clamp current, I_{IK} ($V_I < 0$) -50mA	Storage temperature range, T_{STG} -65°C to 150°C
Output clamp current, I_{OK} ($V_O < 0$) -50mA	

Note:

Stresses greater than those listed under MAXIMUM RATINGS may cause permanent damage to the device. This is a stress rating only and functional operation of the device at these or any other conditions above those indicated in the operational sections of this specification is not implied. Exposure to absolute maximum rating conditions for extended periods may affect reliability.

Recommended Operating Conditions for V_{CCB} at 3.3V⁽⁴⁾

		Min.	Max.	Units
$V_{CCB}^{(1)}$	Supply voltage	3.0	3.6	V
V_{IH}	High-level voltage	2		
V_{IL}	Low-level voltage		0.8	
V_{IA}	Input Voltage	0	V_{CCB}	
V_{OB}	Output Voltage	0	V_{CCB}	mA
I_{OH}	High-level output current		-12	
I_{OL}	Low-level output current		12	
$\Delta t/\Delta v$	Input transition rise or fall rate		10	ns/V
T_A	Operating free-air temperature	-40	85	$^\circ\text{C}$

Recommended Operating Conditions for V_{CCA} at 2.5V⁽⁴⁾

		Min.	Max.	Units
$V_{CCA}^{(2)}$	Supply voltage	2.3	2.7	V
V_{IH}	High-level voltage	$V_{CCA} = 2.3\text{V to } 2.7\text{V}$	1.7	
V_{IL}	Low-level voltage	$V_{CCA} = 2.3\text{V to } 2.7\text{V}$	0.7	
V_{IB}	Input voltage	0	V_{CCA}	
V_{OA}	Output voltage	0	V_{CCA}	mA
I_{OH}	High-level output current	$V_{CCA} = 2.3\text{V}$	-8	
		$V_{CCA} = 2.7\text{V}$	-12	
I_{OL}	Low-level output current	$V_{CCA} = 2.3\text{V}$	8	
		$V_{CCA} = 2.7\text{V}$	12	
$\Delta t/\Delta v$	Input transition rise or fall rate		10	ns/V
T_A	Operating free-air temperature	-40	85	$^\circ\text{C}$

Notes:

1. This value is limited to 4.6V maximum.
2. This value is limited to 3.8V maximum.
3. The package thermal impedance is calculated in accordance with JESD 51.
4. To ensure proper device operation, all unused device inputs must be held at the associated V_{CC} or GND.

Recommended Operating Conditions for V_{CCA} at 1.5V⁽²⁾

		Min.	Max.	Units
$V_{CCA(1)}$	Supply voltage	1.4	1.6	V
V_{IH}	High-level voltage	$V_{CCA} = 1.4V \text{ to } 1.6V$	$0.65 \times V_{CCA}$	
V_{IL}	Low-level voltage	$V_{CCA} = 1.4V \text{ to } 1.6V$	$0.35 \times V_{CCA}$	
V_{IB}	Input voltage	0	V_{CCA}	
V_{OA}	Output voltage	0	V_{CCA}	
I_{OH}	High-level output current	$V_{CCA} = 1.4V$	-2	mA
		$V_{CCA} = 1.6V$	-6	
I_{OL}	Low-level output current	$V_{CCA} = 1.4V$	2	
		$V_{CCA} = 1.6V$	6	
$\Delta t/\Delta v$	Input transition rise or fall rate		10	ns/V
T_A	Operating free-air temperature	-40	85	°C

Electrical Characteristics (V_{CCB}) (Over recommended operating free-air temperature range for $V_{CCB} = 3.3V$)

Parameters		Test Conditions	V_{CCB}	Min.	Typ ⁽³⁾	Max.	Units
V_{OH} (A to B)	$I_{OH} = -100\mu A$		3.0V	2.8			V
			3.6V	3.4			
	$I_{OH} = -12mA$		3.0V	2.2			
			3.6V	2.8			
V_{OL} (A to B)	$I_{OL} = 100\mu A$		3.0V			0.2	V
			3.6V			0.2	
	$I_{OL} = 12mA$		3.0V			0.5	
			3.6V			0.5	
I_I	Control Inputs	$V_I = V_{CCB} \text{ or } GND$	3.6V			± 5	μA
$I_{OZ}^{(4)}$	A or B ports	$V_O = V_{CCB} \text{ or } GND$	3.6V			± 10	
I_{CC}		$V_I = V_{CCB} \text{ or } GND, I_O = 0$	3.6V			20	
$\Delta I_{CC}^{(5)}$		One input at $V_{CCB} - 0.6V$, Other inputs at $V_{CCB} \text{ or } GND$	3.0V to 3.6V			500	
C_I	Control Inputs	$V_I = V_{CCB} \text{ or } GND$	3.3V		4.5		pF
C_{IO}	A or B ports	$V_O = V_{CCB} \text{ or } GND$	3.3V		6.5		

Notes:

1. Value limited to 4.6V maximum..
2. To ensure proper device operation, all unused device inputs must be held at the associated V_{CC} or GND.
3. Typical values are measured at $V_{CC} = 3.3V, T_A = 25^\circ C$
4. For I/O ports, the parameter I_{OZ} includes the input leakage current.
5. This is the increase in supply current for each input that is at one of the specified TTL voltage levels rather than at 0 or the associated V_{CC} .

Electrical Characteristics (V_{CCA}) (Over recommended operating free-air temperature range for V_{CCA} = 2.5V)

Parameters		Test Conditions	V _{CCA}	Min.	Typ. ⁽²⁾	Max.	Units
V _{OH} (B to A)		I _{OH} = -100μA	2.3V to 2.7V	V _{CC} -0.1			V
		I _{OH} = -8mA	2.3V	1.7			
		I _{OH} = -12mA	2.7V	2.0			
V _{OL} (B to A)		I _{OL} = 100μA	2.3V to 2.7V			0.2	V
		I _{OL} = 8mA	2.3V			0.4	
		I _{OL} = 12mA	2.7V			0.5	
I _I	Control Inputs	V _I = V _{CCA} or GND	2.7V			±5	μA
I _{OZ} ⁽³⁾	A or B ports	V _O = V _{CCA} or GND	2.7V			±10	
I _{CC}		V _I = V _{CCA} or GND, I _O = 0	2.7V			30	
ΔI _{CC} ⁽¹⁾		One input at V _{CCA} -0.6V, Other inputs at V _{CCA} or GND	2.3V to 2.7V			500	
C _I	Control Inputs	V _I = V _{CCA} or GND	2.5V		4.5		pF
C _{IO}	A or B ports	V _O = V _{CCA} or GND	2.5V		6.5		

Electrical Characteristics (V_{CCA}) (Over recommended operating free-air temperature range for V_{CCA} = 1.5V)

Parameters		Test Conditions	V _{CCA}	Min.	Typ. ⁽²⁾	Max.	Units
V _{OH} (B to A)		I _{OH} = -100μA	1.4V to 1.6V	V _{CC} -0.1			V
		I _{OH} = -2mA	1.4V	1.1			
		I _{OH} = -6mA	1.6V	1.3			
V _{OL} (B to A)		I _{OL} = 100μA	1.4V			0.2	V
		I _{OL} = 2mA	1.6V			0.3	
		I _{OL} = 6mA	1.6V			0.4	
I _{OZ} ⁽³⁾	A or B ports	V _O = V _{CCA} or GND	1.6V			±5	μA
I _{CC}		V _I = V _{CCA} or GND, I _O = 0	1.6V			±20	
ΔI _{CC} ⁽¹⁾		One input at V _{CCA} -0.6V, Other inputs at V _{CCA} or GND	1.4V to 1.6V			300	
C _I	Control Inputs	V _I = V _{CCA} or GND	1.5V		4.5		pF
C _{IO}	A or B ports	V _O = V _{CCA} or GND	1.5V		6.5		

Notes:

1. The increase in supply current for each input at one of the specified TTL voltage levels rather than at the associated V_{CC}.
2. Typical values are measured at V_{CC} = 2.5V or 1.5V, T_A = 25°C
3. For I/O ports, the parameter I_{OZ} includes the input leakage current.

Switching Characteristics

(Over recommended operating free-air temperature range, $C_L = 30\text{pF}$ (unless otherwise noted), see Figures 1, 2, 3)

Parameter	From (Input)	To (Output)	PI74AVC164245LA				Units
			$V_{CCB} = 3.3\text{V} \pm 0.3\text{V}$				
			$V_{CCA} = 1.5\text{V} \pm 0.10\text{V}$		$V_{CCA} = 2.5\text{V} \pm 0.2\text{V}$		
			Min.	Max.	Min.	Max.	
t_{PD}	A	B	1.0	3.5	1.0	3.0	ns
	B	A	1.0	3.5	1.0	2.8	
t_{EN}	\overline{OE}	B	1.7	4.5	1.2	3.5	
t_{DIS}	\overline{OE}	B	1.5	4.5	1.0	3.5	
t_{EN}	\overline{OE}	A	1.7	4.5	1.2	3.5	
t_{DIS}	\overline{OE}	A	2.0	4.5	1.5	3.5	
$t_{sk(o)}^{(1)}$						0.3	
$t_{sk(b)}^{(1)}$						0.25	

Note:

1. This is the skew between any two outputs of the same package, and switching in the same direction. For $t_{sk(o)}$, Output 1 and Output 2 are any two outputs. For $t_{sk(b)}$, Output 1 and Output 2 are in the same bank. These parameters are warranted but not production tested.

Operating Characteristics, $T_A = 25^\circ\text{C}$

Parameters		Test Conditions	$V_{CCA} = 2.5\text{V}$ $V_{CCB} = 3.3\text{V}$	Units
			Typical	
C_{PD} Power Dissipation Capacitance	Outputs Enabled (A or B)	$C_L = 30\text{pF}$, $F = 10\text{MHz}$	56	pF
			6	

Parameter Measurement Information, $V_{CCA} = 1.5V \pm 0.10V$

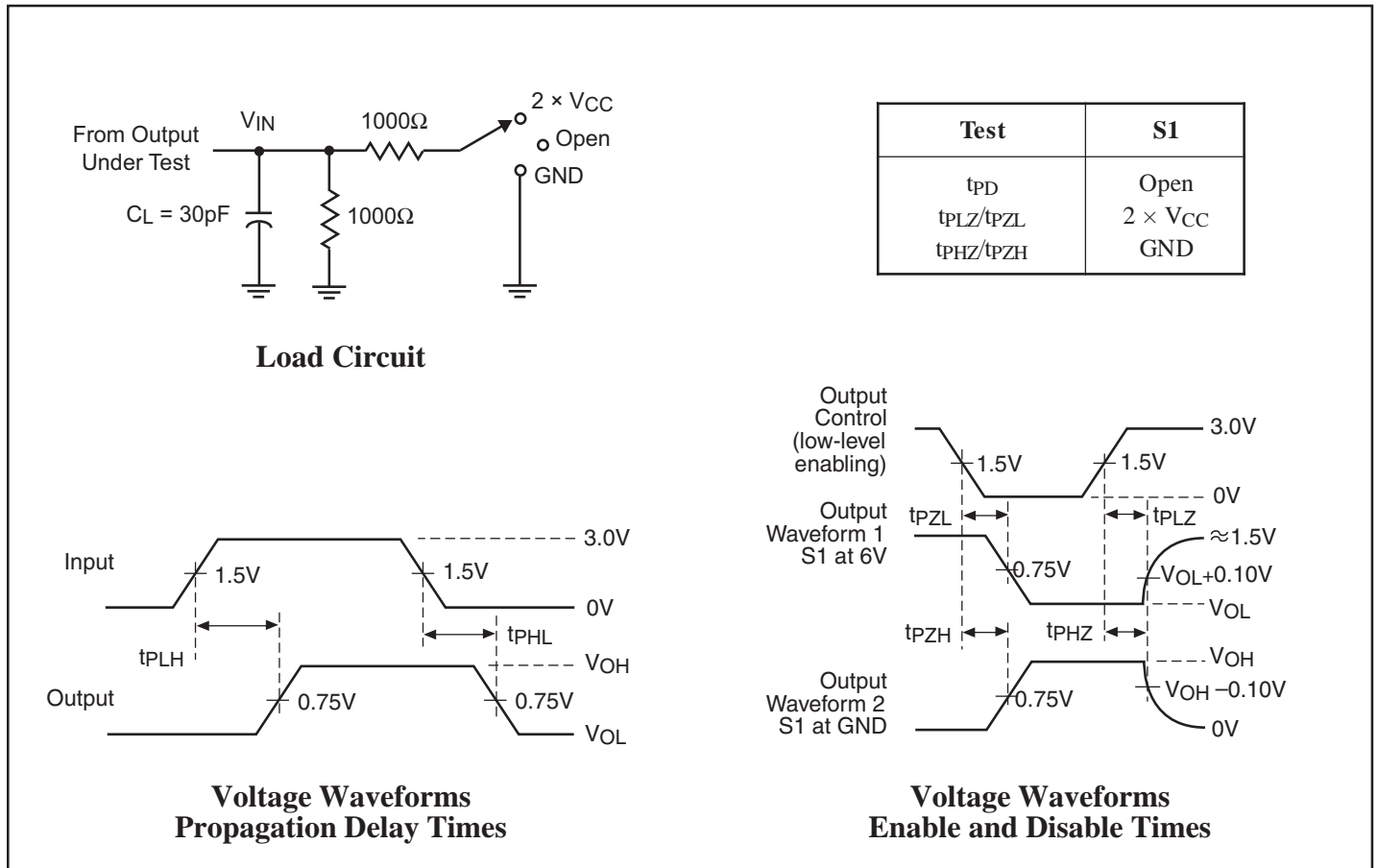

Figure 1. Load Circuit and Voltage Waveforms

Notes:

- C_L includes probe and jig capacitance.
- Waveform 1 is for an output with internal conditions such that the output is low except when disabled by the output control.
Waveform 2 is for an output with internal conditions such that the output is high except when disabled by the output control.
- All input pulses are supplied by generators having the following characteristics: $PRR \leq 10Mz$, $Z_O = 50\Omega$, $t_R \leq 2.5ns$, $t_F \leq 2.5ns$.
- The outputs are measured one at a time with one transition per measurement.
- t_{PLZ} and t_{PHZ} are the same as t_{DIS} .
- t_{PZL} and t_{PZH} are the same as t_{EN} .
- t_{PLH} and t_{PHL} are the same as t_{PD} .

Parameter Measurement Information, $V_{CCA} = 2.5V \pm 0.2V$

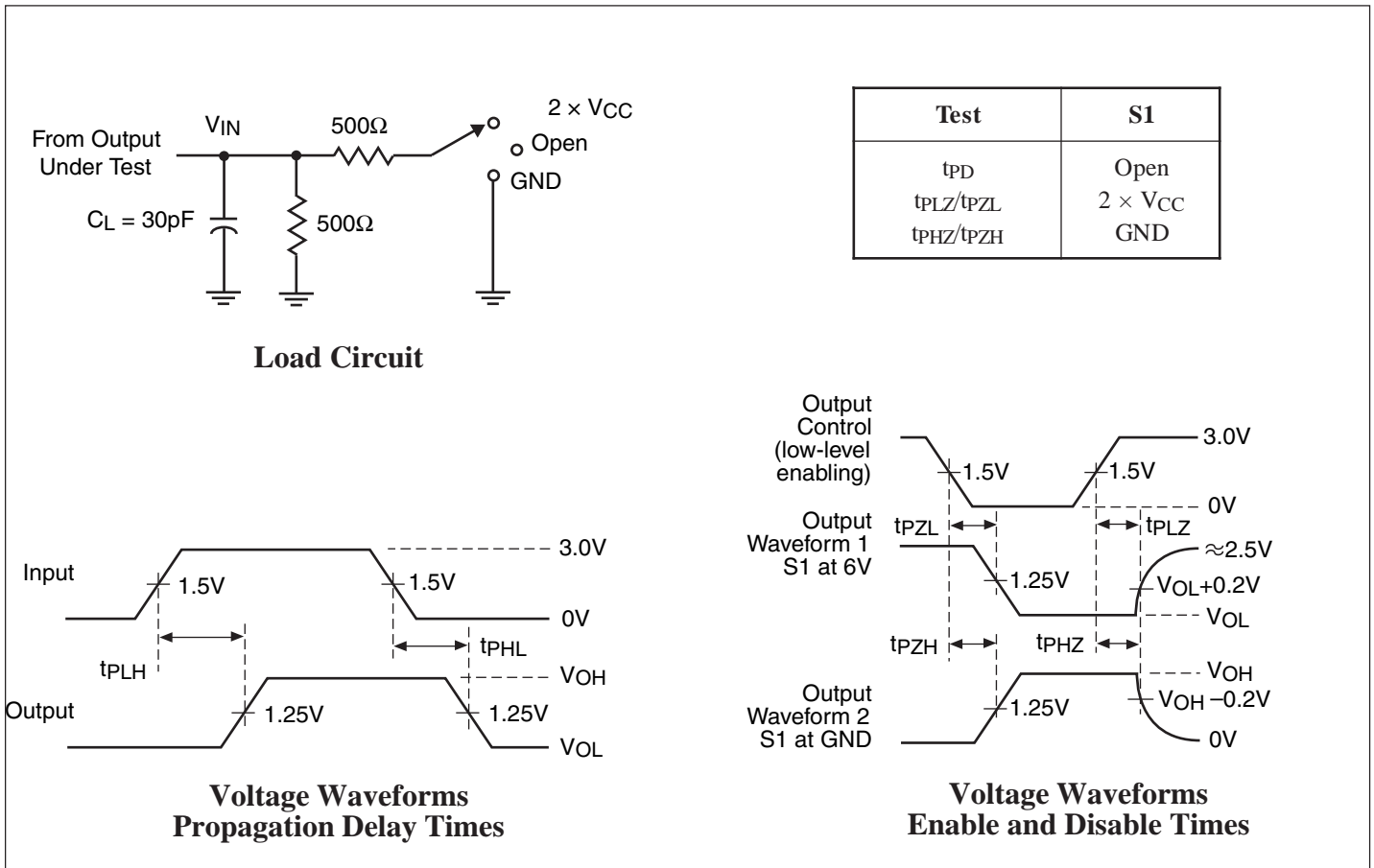

Figure 2. Load Circuit and Voltage Waveforms

Notes:

- C_L includes probe and jig capacitance.
- Waveform 1 is for an output with internal conditions such that the output is low except when disabled by the output control.
- Waveform 2 is for an output with internal conditions such that the output is high except when disabled by the output control.
- All input pulses are supplied by generators having the following characteristics: $PRR \leq 10\text{Mz}$, $Z_O = 50\Omega$, $t_R \leq 2.5\text{ns}$, $t_F \leq 2.5\text{ns}$.
- The outputs are measured one at a time with one transition per measurement.
- t_{PLZ} and t_{PHZ} are the same as t_{DIS}.
- t_{PZL} and t_{PZH} are the same as t_{EN}.
- t_{PLH} and t_{PHL} are the same as t_{PD}.

Parameter Measurement Information, $V_{CCB} = 3.3V \pm 0.3V$

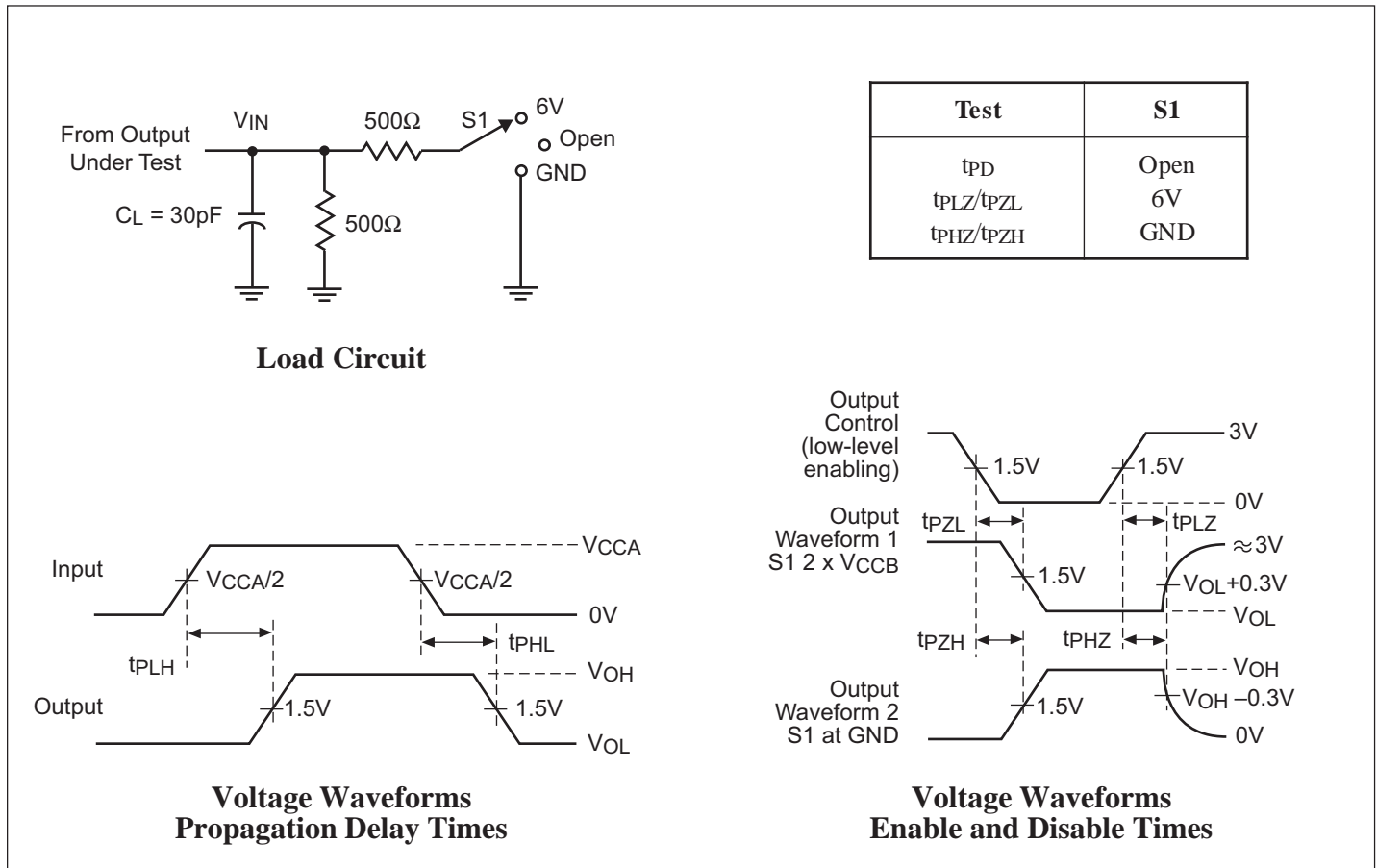

Figure 3. Load Circuit and Voltage Waveforms

Notes:

- C_L includes probe and jig capacitance.
- Waveform 1 is for an output with internal conditions such that the output is low except when disabled by the output control.
Waveform 2 is for an output with internal conditions such that the output is high except when disabled by the output control.
- All input pulses are supplied by generators having the following characteristics: $PRR \leq 10\text{Mz}$, $Z_O = 50\Omega$, $t_R \leq 2.5\text{ns}$, $t_F \leq 2.5\text{ns}$.
- The outputs are measured one at a time with one transition per measurement.
- t_{PLZ} and t_{PHZ} are the same as t_{DIS} .
- t_{PZL} and t_{PZH} are the same as t_{EN} .
- t_{PLH} and t_{PHL} are the same as t_{PD} .

Packaging Mechanical: 48-Pin TSSOP (A)

DOCUMENT CONTROL NO.
 PD - 1501

REVISION: G
 DATE: 03/09/05

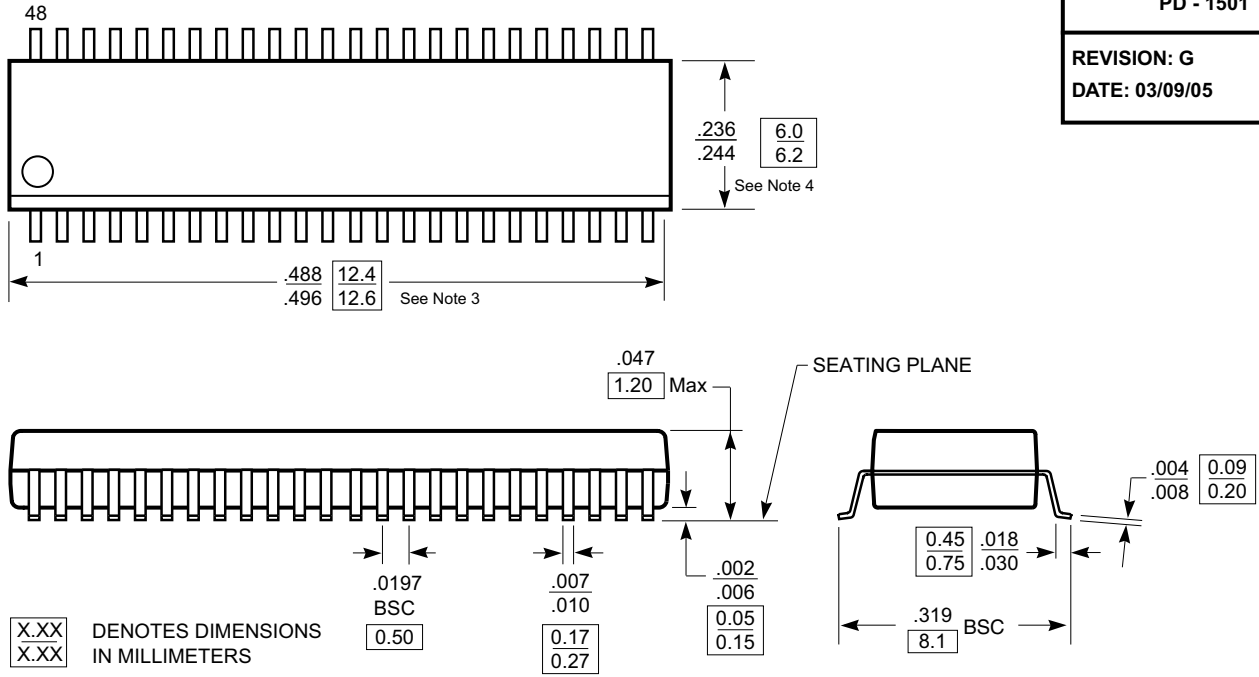

- Note:**
- Controlling dimensions in millimeters.
 - Ref: JEDEC MO-153F/ED
 - Dimension does not include mold flash, protrusions or gate burrs. Mold flash, protrusions and gate burrs shall not exceed 0.15mm per side.
 - Dimension does not include interlead flash or protrusion. Interlead flash or protrusion shall not exceed 0.25mm per side.



Pericom Semiconductor Corporation
 3545 N. 1st Street, San Jose, CA 95134
 1-800-435-2335 • www.pericom.com

DESCRIPTION: 48-Pin 240-Mil Wide TSSOP

PACKAGE CODE: A

Packaging Mechanical: 48-Pin TVSOP (K)

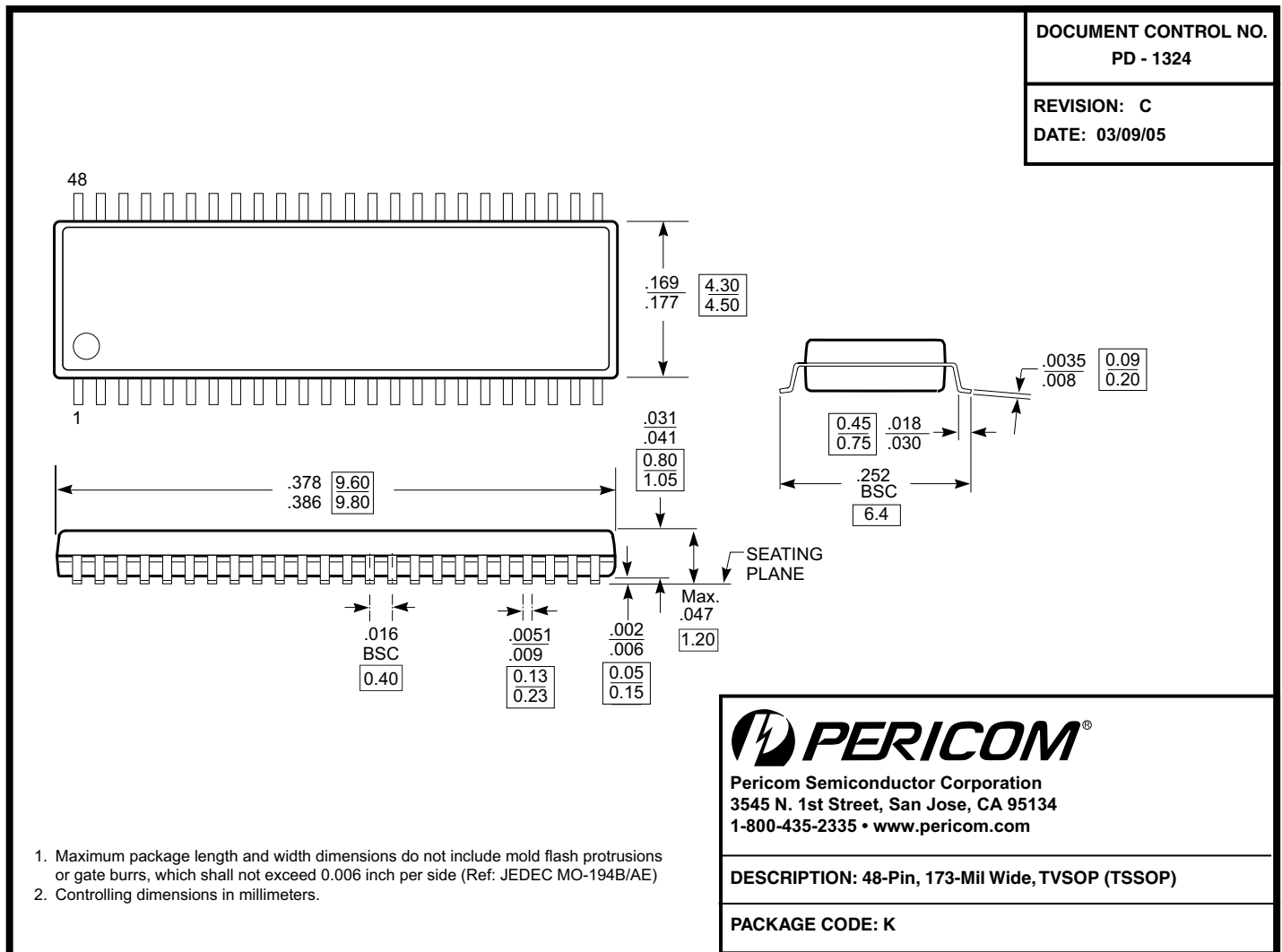

Ordering Information

Ordering Code	Package Code	Speed Grade	Package Description
PI74AVC164245LAAE	A	A	Pb-free & Green, 48-pin, 240-mil wide plastic TSSOP
PI74AVC164245LAKE	K	A	Pb-free & Green, 48-pin, 173-mil wide plastic TVSOP

Notes:

- Thermal characteristics can be found on the company web site at www.pericom.com/packaging/

X-ON Electronics

Largest Supplier of Electrical and Electronic Components

Click to view similar products for [Bus Transceivers](#) category:

Click to view products by [Pericom](#) manufacturer:

Other Similar products are found below :

[74LS645N](#) [DS8838](#) [FXL4TD245UMX](#) [IDT74CBTLV3257PGG](#) [74LVT245BBT20-13](#) [5962-8683401DA](#) [PCA9617ADMR2G](#) [5962-8953501KA](#) [5962-86834012A](#) [5962-7802301Q2A](#) [5962-7802002MFA](#) [5962-7802001MFA](#) [74VHCV245FT\(BJ\)](#) [NCV7349D13R2G](#) [TC74VCX164245\(EL,F](#) [MC74LCX245MNTWG](#) [TC7WPB8306L8X,LF\(S](#) [TC7WPB9307FC\(TE85L](#) [74FCT16245CTPVG8](#) [74FCT16543CTPVG](#) [74FCT245CTPYG8](#) [MM74HC245AMTCX](#) [74LVCH16245APVG](#) [74LVX245MTC](#) [5962-9221405M2A](#) [NTS0102DP-Q100H](#) [74ALVC16245MTDX](#) [74ALVCH32245BF](#) [74FCT163245APVG](#) [74FCT245ATPYG8](#) [74FCT245CTQG](#) [74FCT3245AQG](#) [74LCXR162245MTX](#) [74VHC245M](#) [74VHC245MX](#) [TC7WPB9306FC\(TE85L](#) [TC7WPB9306FK\(T5L,F](#) [JM38510/65553BRA](#) [ST3384EBDR](#) [74LVC1T45GF,132](#) [74AVC4TD245BQ,115](#) [PQJ7980AHN/C0JL,51](#) [MC100EP16VBDG](#) [FXL2TD245L10X](#) [74LVC1T45GM,115](#) [TC74AC245P\(F\)](#) [PSB21150F S LLHR](#) [SNJ54LS245FK](#) [SNJ54AHC245J](#) [SNJ54ABT245AFK](#)