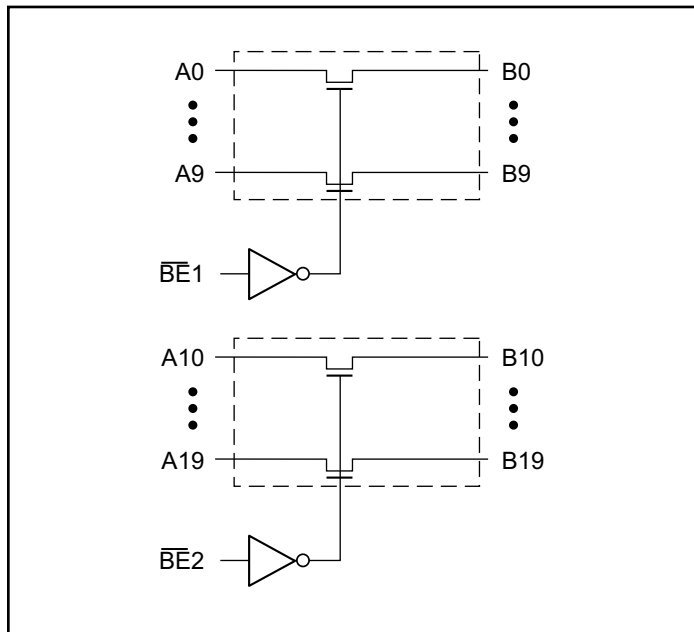

**20-Bit, 2-Port Bus Switch**
**Features**

- Near-Zero propagation delay
- 5Ω or 25Ω switches connect inputs to outputs
- Direct bus connection when switches are ON
- 32X384 function with flow through pinout make board layout easier
- Ultra-low quiescent power (0.2μA typical)
  - Ideally suited for notebook applications
- Industrial operating temperature: -40°C to +85°C
- Packaging (Pb-free & Green):
  - 48-pin 240-mil wide plastic TSSOP (A)

**Block Diagram**

**Truth Table<sup>(1)</sup>**

Function	BEx	A19-A0
Disconnect	H	Hi-Z
Connect	$\overline{L}$	B19-B0

**Note:**

1. H = High Voltage Level, L = Low Voltage Level, Hi-Z = High Impedance

**Description**

Pericom Semiconductor's PI5C16861 is configured as a 20-bit, 2-port bus switch designed with a low On-Resistance (5Ω) allowing inputs to be connected directly to outputs. The bus switch creates no additional propagational delay or additional ground bounce noise. The switches are turned ON by the Bus Enable (BĒx) input signal.

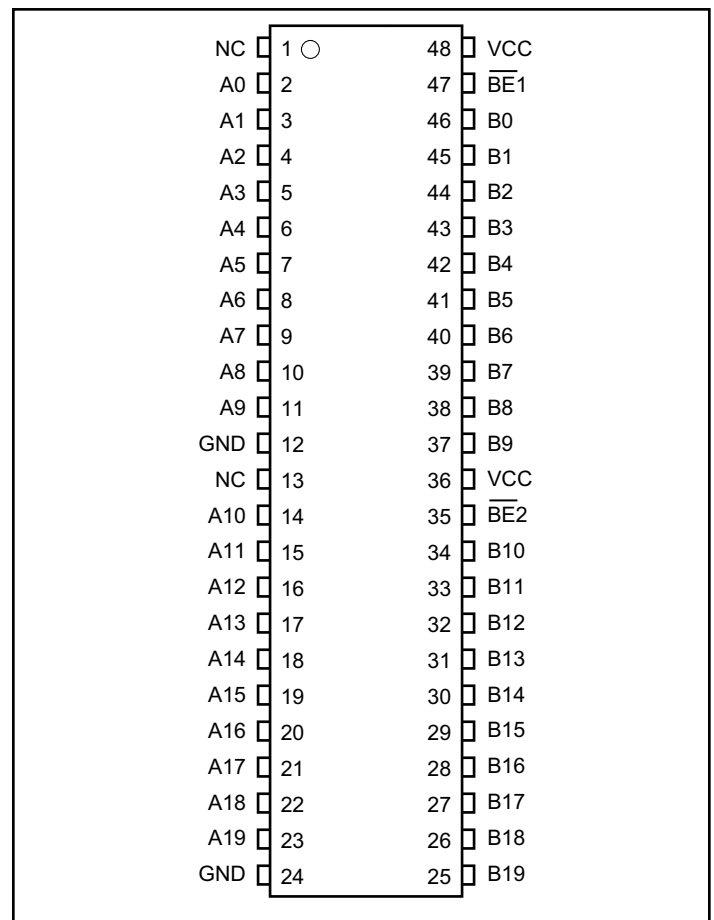
**Pin Configuration**

**Pin Description**

Pin Name	Description
BEx	Bus Enable Inputs (Active LOW)
A19-A0	Bus A
B19-B0	Bus B

### Maximum Ratings

(Above which the useful life may be impaired. For user guidelines, not tested.)

Storage Temperature .....	-65°C to +150°C
Ambient Temperature with Power Applied .....	-40°C to +85°C
Supply Voltage to Ground Potential (Inputs & V <sub>CC</sub> Only).....	-0.5V to +7.0V
Supply Voltage to Ground Potential (Outputs & D/O Only) ...	-0.5V to +7.0V
DC Input Voltage .....	-0.5V to +7.0V
DC Output Current.....	120mA
Power Dissipation .....	0.5W

**Note:**

Stresses greater than those listed under MAXIMUM RATINGS may cause permanent damage to the device. This is a stress rating only and functional operation of the device at these or any other conditions above those indicated in the operational sections of this specification is not implied. Exposure to absolute maximum rating conditions for extended periods may affect reliability.

### DC Electrical Characteristics (Over the Operating Range, T<sub>A</sub> = -40°C to +85°C, V<sub>CC</sub> = 5V ±10%)

Parameters	Description	Test Conditions <sup>(1)</sup>	Min.	Typ. <sup>(2)</sup>	Max.	Units
V <sub>IH</sub>	Input HIGH Voltage	Guaranteed Logic HIGH Level	2.0			V
V <sub>IL</sub>	Input LOW Voltage	Guaranteed Logic LOW Level	-0.5		0.8	
I <sub>IH</sub>	Input HIGH Current	V <sub>CC</sub> = Max., V <sub>IN</sub> = V <sub>CC</sub>			±1	μA
I <sub>IL</sub>	Input LOW Current	V <sub>CC</sub> = Max., V <sub>IN</sub> = GND			±1	
I <sub>OZH</sub>	High Impedance Output Current	0 ≤ A, B ≤ V <sub>CC</sub>			±1	
V <sub>IK</sub>	Clamp Diode Voltage	V <sub>CC</sub> = Min., I <sub>IN</sub> = -18mA		-0.7	-1.2	V
I <sub>ON</sub>	Short Circuit Current <sup>(3)</sup>	A (B) = 0V, B (A) = V <sub>CC</sub>	100			mA
V <sub>H</sub>	Input Hysteresis at Control Pins			150		mV
R <sub>ON</sub>	Switch On-Resistance <sup>(4)</sup>	V <sub>CC</sub> = Min., V <sub>IN</sub> = 0.0V		5	7	Ω
		V <sub>CC</sub> = Min., V <sub>IN</sub> = 2.4V		10	15	

**Notes:**

- For Max. or Min. conditions, use appropriate value specified under Electrical Characteristics for the applicable device type.
- Typical values are at V<sub>CC</sub> = 5.0V, T<sub>A</sub> = 25°C ambient and maximum loading.
- Not more than one output should be shorted at one time. Duration of the test should not exceed one second.
- Measured by the voltage drop between A and B pin at indicated current through the switch. On-Resistance is determined by the lower of the voltages on the two (A,B) pins.

### Capacitance (T<sub>A</sub> = 25°C, f = 1 MHz)

Parameters <sup>(1)</sup>	Description	Test Conditions	Typ.	Units
C <sub>IN</sub>	Input Capacitance	V <sub>IN</sub> = 0V	6	pF
C <sub>OFF</sub>	A/B Capacitance, Switch Off		6	
C <sub>ON</sub>	A/B Capacitance, Switch On		8	

**Notes:**

- This parameter is determined by device characterization but is not production tested.

**Power Supply Characteristics**

Parameters	Description	Test Conditions <sup>(1)</sup>		Min.	Typ. <sup>(2)</sup>	Max.	Units
I <sub>CC</sub>	Quiescent Power Supply Current	V <sub>CC</sub> = Max.	V <sub>IN</sub> = GND or V <sub>CC</sub>		0.1	10	μA
ΔI <sub>CC</sub>	Supply Current per Input @ TTL HIGH	V <sub>CC</sub> = Max.	V <sub>IN</sub> = 3.4V <sup>(3)</sup>			2.5	mA
I <sub>CCD</sub>	Supply Current per Input per MHz <sup>(4)</sup>	V <sub>CC</sub> = Max., A and B Pins Open $\overline{\text{BEx}}$ = GND, Control Input Toggling 50% Duty Cycle				0.25	mA/ MHz

**Notes:**

- For Max. or Min. conditions, use appropriate value specified under Electrical Characteristics for the applicable device.
- Typical values are at V<sub>CC</sub> = 5.0V, +25°C ambient.
- Per TTL driven input (V<sub>IN</sub> = 3.4V, control inputs only); A and B pins do not contribute to I<sub>CC</sub>.
- This current applies to the control inputs only and represent the current required to switch internal capacitance at the specified frequency. The A and B inputs generate no significant AC or DC currents as they transition. This parameter is not tested, but is guaranteed by design.

**PI5C16861 Switching Characteristics over Operating Range**

Parameters	Description	Conditions	PI5C16861		Unit
			Com.		
			Min.	Max.	
t <sub>PLH</sub> t <sub>PHL</sub>	Propagation Delay <sup>(1,2)</sup> Ax to Bx, Bx to Ax	C <sub>L</sub> = 50pF R <sub>L</sub> = 500Ω		1.25	ns
t <sub>PZH</sub> t <sub>PZL</sub>	Bus Enable Time $\overline{\text{BEx}}$ to Ax or Bx		1.5	6.5	
t <sub>PHZ</sub> t <sub>PLZ</sub>	Bus Disable Time $\overline{\text{BEx}}$ to Ax or Bx		1.5	5.5	

**Notes:**

- This parameter is guaranteed but not tested on Propagation Delays.
- The bus switch contributes no propagational delay other than the RC delay of the On-Resistance of the switch and the load capacitance. The time constant for the switch alone is of the order of 0.25ns for 50pF load. Since this time constant is much smaller than the rise/fall times of typical driving signals, it adds very little propagational delay to the system. Propagational delay of the bus switch when used in a system is determined by the driving circuit on the driving side of the switch and its interaction with the load on the driven side.

Packaging Mechanical: 48-pin BSQOP (B)

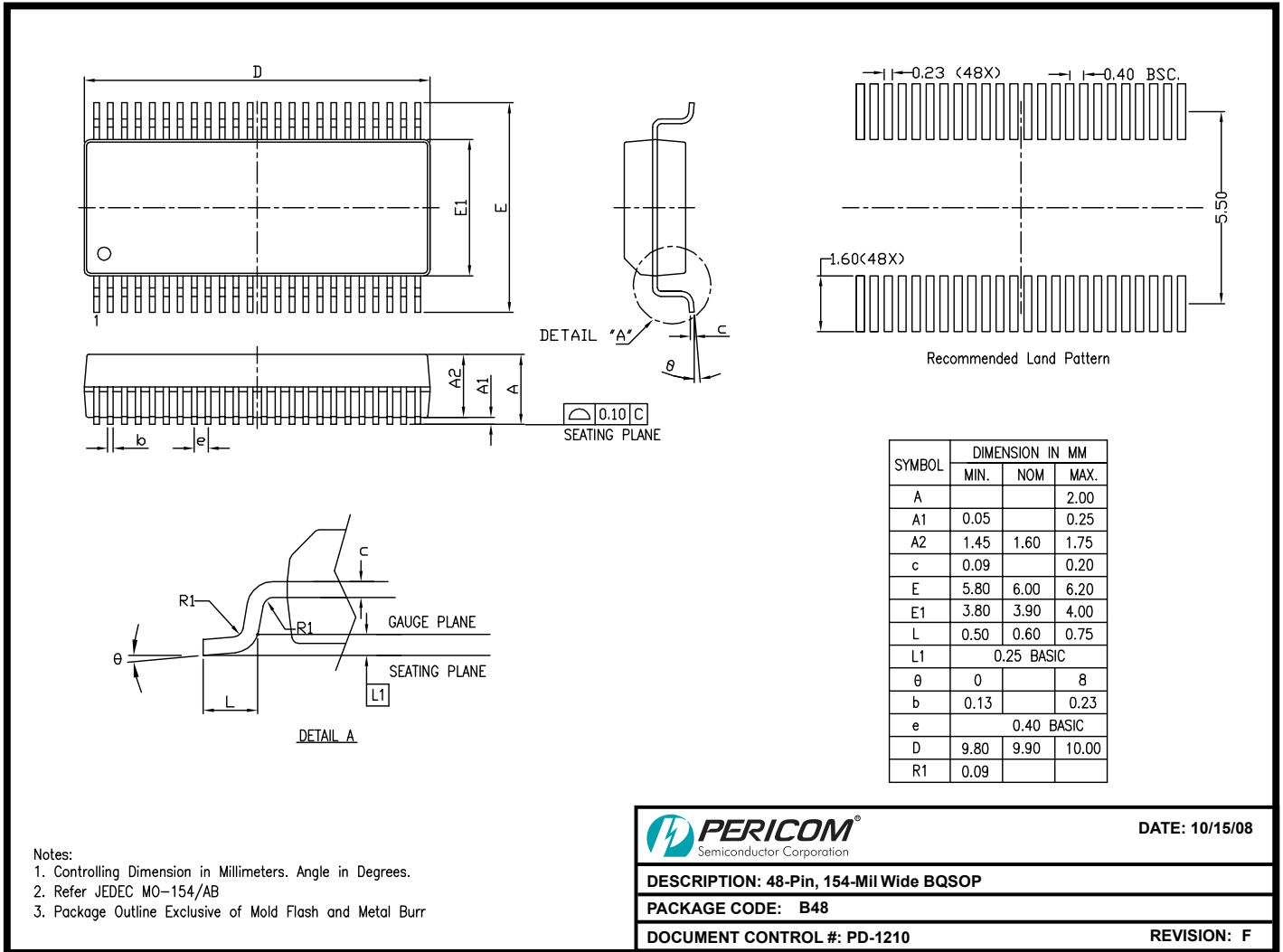

SYMBOL	DIMENSION IN MM		
	MIN.	NOM.	MAX.
A			2.00
A1	0.05		0.25
A2	1.45	1.60	1.75
c	0.09		0.20
E	5.80	6.00	6.20
E1	3.80	3.90	4.00
L	0.50	0.60	0.75
L1	0.25 BASIC		
θ	0		8
b	0.13		0.23
e	0.40 BASIC		
D	9.80	9.90	10.00
R1	0.09		

**Notes:**  
 1. Controlling Dimension in Millimeters. Angle in Degrees.  
 2. Refer JEDEC MO-154/AB  
 3. Package Outline Exclusive of Mold Flash and Metal Burr

**PERICOM**  
Semiconductor Corporation

DATE: 10/15/08

DESCRIPTION: 48-Pin, 154-Mil Wide BQSOP

PACKAGE CODE: B48

DOCUMENT CONTROL #: PD-1210

REVISION: F

Ordering Information

Ordering Code	Package Type	Package Description
PI5C16861AE	A	Pb-free & Green, 48-Pin, TSSOP

Notes:

- Thermal characteristics can be found on the company web site at [www.pericom.com/packaging/](http://www.pericom.com/packaging/)
- E = Pb-free & Green
- Adding an X suffix = Tape/Reel

## X-ON Electronics

Largest Supplier of Electrical and Electronic Components

*Click to view similar products for [Digital Bus Switch ICs](#) category:*

*Click to view products by [Pericom](#) manufacturer:*

Other Similar products are found below :

[MT8986AE1](#) [MT90812AP1](#) [MT90869AG2](#) [CA91L8260B-100CEV](#) [TC7MPB9307FT\(EL\)](#) [MT8986AP1](#) [72V8985JG8](#) [732757E](#)  
[ZL50020QCG1](#) [ZL50012QCG1](#) [PI3C32X384BE](#) [PI5C3861QEX](#) [ZL50023GAG2](#) [MT8986AL1](#) [MT8981DP1](#) [PI3VT3245-ALE](#)  
[ZL50016GAG2](#) [TC7MBL3257CFT\(EL\)](#) [PI3CH800QE](#) [MT90823AB1](#) [ZL50075GAG2](#) [PI5C32X245BEX](#) [PI5C3126QEX](#) [PI5C3125QEX](#)  
[PI3VT3245-AQE](#) [PI3CH800QEX](#) [PI3C3384QE](#) [PI3C3305UEX](#) [PI3B3861QEX](#) [PI3B3861QE](#) [PI3B32X245BEX](#) [PI3B3245QEX](#)  
[PI3B3245QE](#) [PI3CH800ZHEX](#) [PI3CH1000LE](#) [PI3CH400ZBEX](#) [728981JG8](#) [TC7MBL3257CFK\(EL\)](#) [728985JG8](#) [PI3CH401LE](#)  
[PI3CH401LEX](#) [FST3126DR2G](#) [QS34X245Q3G8](#) [QS3VH125S1G8](#) [TC7WBL3305CFK\(5L,F](#) [74CB3Q3125DBQRE4](#) [74FST6800PGG8](#)  
[74CB3Q3244DBQRE4](#) [74CBTLV3125PGG8](#) [TC7MBL3125CFT\(EL\)](#)