

## Electronic device circuit breaker - ECP-E 2A - 0900210

Please be informed that the data shown in this PDF Document is generated from our Online Catalog. Please find the complete data in the user's documentation. Our General Terms of Use for Downloads are valid (<http://phoenixcontact.com/download>)



Electronic device circuit breaker, number of positions: 1, connection method: Screw connection, width: 12.5 mm, fuse type: electronic, fuse type: Automatic device, mounting type: on base element, Color: black

### Your advantages

- ✔ Can be plugged onto TMCP SOCKET M base
- ✔ Design width of just 12.5 mm
- ✔ The operating or error state is indicated by a multi-color LED as well as an integrated status output (12)



### Key Commercial Data

Packing unit	5 pc
GTIN	
GTIN	4046356103992

### Technical data

#### General

Installation instructions	When mounted in rows without convection cooling, the nominal device current should only be led to a maximum of 80% due to the thermal effect during continuous operation (100% operating factor). Special precautionary measures must be taken in systems or machines, to prevent components from restarting (e.g., use of a safety PLC). Parallel connection of multiple circuit breakers is not permitted.
Mounting type	on base element
Color	black
Number of positions	1
Overvoltage category	II
Insulating material	PA66/6
Flammability rating according to UL 94	V0

#### Electrical data

Fuse	electronic
Fuse type	Automatic device

# Electronic device circuit breaker - ECP-E 2A - 0900210

## Technical data

### Electrical data

Rated surge voltage	0.5 kV
Operating voltage	24 V DC
	24 V DC (at 50 °C (UL 2367, UL 508, ANSI/ISA 12.12.01))
	18 V DC ... 32 V DC
Nominal current $I_N$	2 A
Required backup fuse	not required, integrated failsafe element
Dielectric strength	max. 32 V DC (Load circuit)
Degree of pollution	2
Overvoltage category	II
Insulating material group	I
Switching capacity $I_{CN}$	Active current limitation
Closed-circuit current range $I_0$	typ. 25 mA $\pm$ 5 mA (When switched on)

### Dimensions

Height	60 mm
Width	12.5 mm
Depth	70 mm
Height NS 35/7,5	144 mm
Height NS 35/15	151.5 mm
Complete module height	115 mm
Complete module width	38 mm
Complete module depth	112.5 mm

### Ambient conditions

Degree of protection	IP30 (Actuation area)
Ambient temperature (operation)	0 °C ... 50 °C (non-condensing)

### Connection data

Connection method	Screw connection
-------------------	------------------

### Standards and Regulations

Standards/specifications	UL 2367
	UL 508
	CSA 22.2 No. 14

### Environmental Product Compliance

REACH SVHC	Lead 7439-92-1
China RoHS	Environmentally Friendly Use Period = 50 years
	For details about hazardous substances go to tab "Downloads", Category "Manufacturer's declaration"

## Drawings

# Electronic device circuit breaker - ECP-E 2A - 0900210

Block diagram

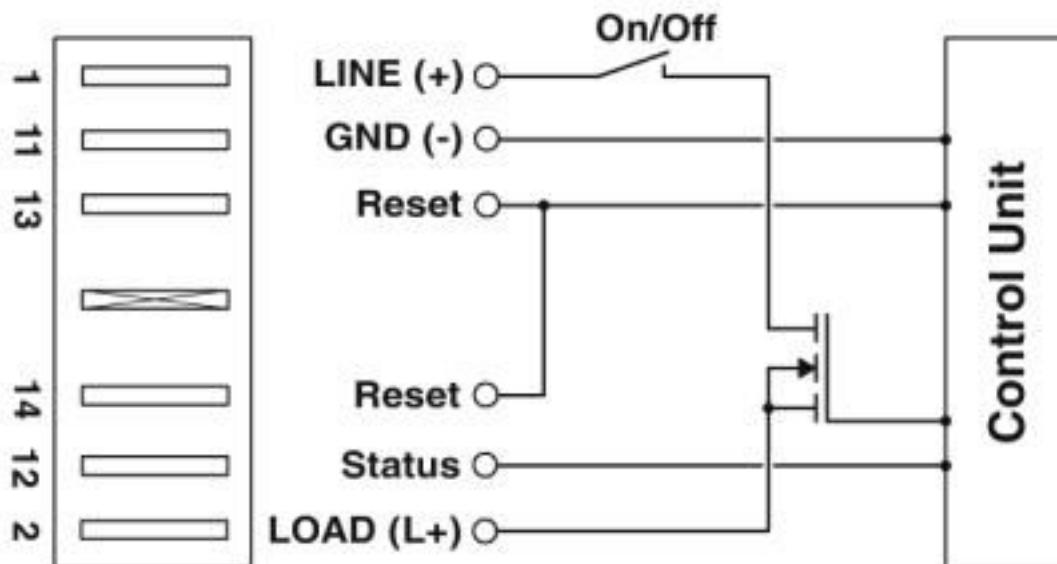

Diagram

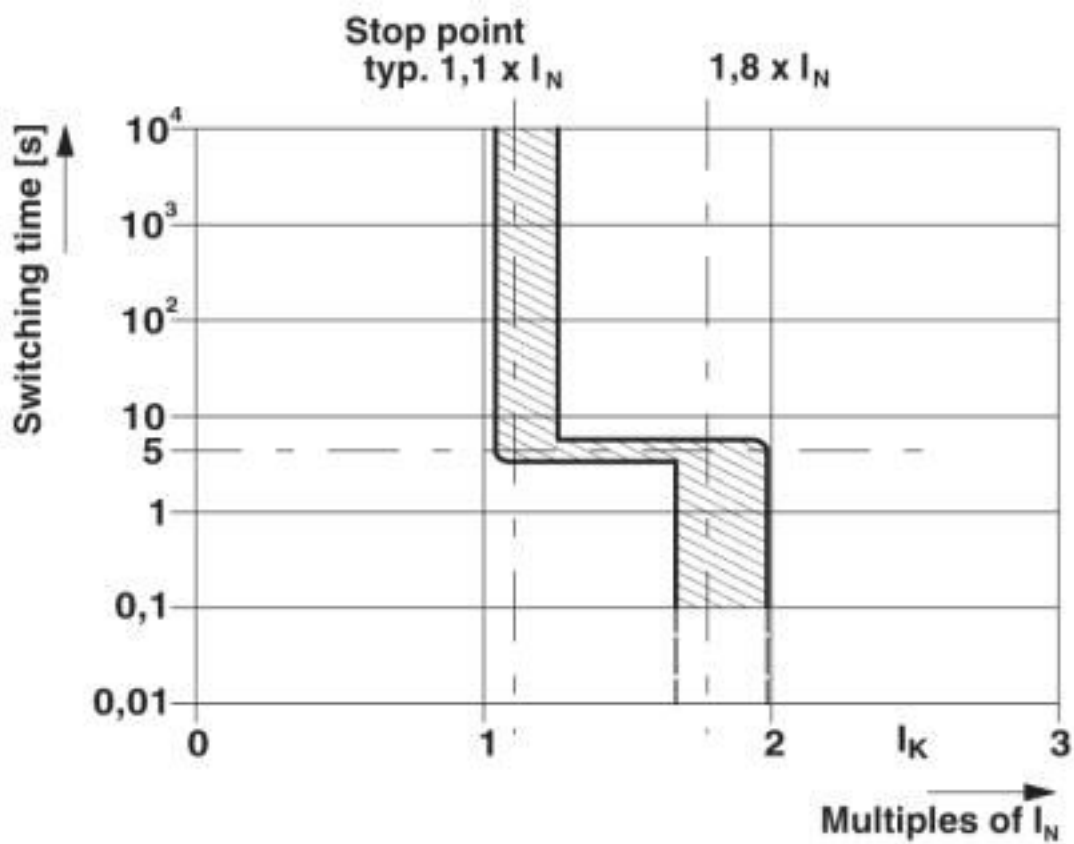

# Electronic device circuit breaker - ECP-E 2A - 0900210

## Classifications

### eCl@ss

eCl@ss 10.0.1	27140401
eCl@ss 4.0	27141100
eCl@ss 4.1	27141100
eCl@ss 5.0	27141100
eCl@ss 5.1	27141100
eCl@ss 6.0	27141100
eCl@ss 7.0	27141116
eCl@ss 8.0	27141116
eCl@ss 9.0	27141116

### ETIM

ETIM 2.0	EC000899
ETIM 3.0	EC000899
ETIM 4.0	EC000899
ETIM 5.0	EC000899
ETIM 6.0	EC000899
ETIM 7.0	EC000899

### UNSPSC

UNSPSC 6.01	30211812
UNSPSC 7.0901	39121411
UNSPSC 11	39121411
UNSPSC 12.01	39121411
UNSPSC 13.2	39121410
UNSPSC 18.0	39121410
UNSPSC 19.0	39121410
UNSPSC 20.0	39121410
UNSPSC 21.0	39121410

## Approvals

### Approvals

---

Approvals

UL Recognized

---

Ex Approvals

UL Recognized / CSA

---

### Approval details

# Electronic device circuit breaker - ECP-E 2A - 0900210

## Approvals

UL Recognized		<a href="http://database.ul.com/cgi-bin/XYV/template/LISEXT/1FRAME/index.htm">http://database.ul.com/cgi-bin/XYV/template/LISEXT/1FRAME/index.htm</a>	FILE E 317172
---------------	--	---	---------------

## Accessories

### Accessories

#### Marker pen

Marker pen - X-PEN 0,35 - 0811228



Marker pen without ink cartridge, for manual labeling of markers, labeling extremely wipe-proof, line thickness 0.35 mm

#### Terminal marking

Zack marker strip - ZB 6:UNBEDRUCKT - 1051003



Zack marker strip, Strip, white, unlabeled, can be labeled with: PLOTMARK, CMS-P1-PLOTTER, mounting type: snap into tall marker groove, for terminal block width: 6.2 mm, lettering field size: 6.15 x 10.5 mm, Number of individual labels: 10

Zack marker strip - ZB 6/WH-100:UNBEDRUCKT - 5060935



Zack marker strip, Strip, white, unlabeled, can be labeled with: PLOTMARK, CMS-P1-PLOTTER, mounting type: snap into tall marker groove, for terminal block width: 6.2 mm, lettering field size: 6.15 x 10.5 mm, Number of individual labels: 10

## Additional products

Box mounting base - TMCP SOCKET M - 0916589



Modular socket element, 2-position, for holding two circuit breakers, each with a single position

## Electronic device circuit breaker - ECP-E 2A - 0900210

### Accessories

End cover - TMCP CONNECT LR - 0916592



End cover, width: 6 mm, Color: black

---

Phoenix Contact 2020 © - all rights reserved  
<http://www.phoenixcontact.com>

PHOENIX CONTACT GmbH & Co. KG  
Flachsmarktstr. 8  
32825 Blomberg  
Germany  
Tel. +49 5235 300  
Fax +49 5235 3 41200  
<http://www.phoenixcontact.com>

## X-ON Electronics

Largest Supplier of Electrical and Electronic Components

*Click to view similar products for [Circuit Breakers](#) category:*

*Click to view products by [Phoenix Contact](#) manufacturer:*

Other Similar products are found below :

[LUGZX66-1-61-20.0-44](#) [M39019/01-201S](#) [M39019/01-221](#) [M39019/01-323](#) [M39019/01-333](#) [M39019/01-336](#) [M39019/02-248](#) [M39019/02-311](#) [M39019/02-316](#) [M39019/04-249S](#) [M39019/05-246S](#) [M39019/06-254S](#) [M55629/1-016](#) [M55629/1-018](#) [M55629/1-021](#) [M55629/1-033](#) [M55629/1-036](#) [M55629/1-046](#) [M55629/1-048](#) [M55629/1-058](#) [M55629/1-067](#) [M55629/1-070](#) [M55629/1-079](#) [M55629/1-084](#) [M55629/1-085](#) [M55629/1-101](#) [M55629/1-109](#) [M55629/11-102](#) [M55629/1-120](#) [M55629/12-045](#) [M55629/12-046](#) [M55629/1-330](#) [M55629/1-366](#) [M55629/1-387](#) [M55629/1-401](#) [M55629/1-450](#) [M55629/2-022](#) [M55629/2-030](#) [M55629/2-072](#) [M55629/2-082](#) [M55629/2-099](#) [M55629/2-101](#) [M55629/2-102](#) [M55629/21-BM-BM](#) [M55629/21-HM-HM](#) [M55629/21-NS-NS](#) [M55629/22-NR-NR-NR](#) [M55629/22-RS-RS-RS](#) [M55629/2-347](#) [M55629/2-401](#)