

# EV-T2G3C-3AC20A-8,0M2,5ESBK01 - AC charging cable



1051542

<https://www.phoenixcontact.com/pl/produkty/1051542>

Please be informed that the data shown in this PDF document is generated from our Online Catalog. Please find the complete data in the user documentation. Our General Terms of Use for Downloads are valid.



CHARX connect comfort, AC charging cable, with vehicle charging connector and open cable end, for charging electric vehicles (EV) with alternating current (AC) via type 2 vehicle charging inlets, with protective cap, Type 2, IEC 62196-2, housing: black, gray, PHOENIX CONTACT logo, cable: 8 m, black, straight, NOTE: Cable management may be required.

## Product Description

AC charging cable with vehicle charging connector and free cable end for charging electric vehicles (EV) with alternating current (AC) via type 2 vehicle charging inlets, for installation at charging stations for e-mobility (EVSE)

## Your advantages

- Complete product range
- Convenient handling due to the ergonomic, triple award-winning design
- Available with your logo on request – for consistent branding of your charging station
- Longitudinal water tightness reliably prevents water ingress
- Developed and produced in accordance with the IATF 16949 automotive standard and ISO 9001
- Tested in accordance with automotive standards LV124, LV214, and LV215-2
- Tested in accordance with EV Ready 37 requirements
- Laser-marked mating face in accordance with DIN EN 17186

## Commercial Data

Item number	1051542
Packing unit	1 pc
Minimum order quantity	1 pc
Sales Key	XWBAAC
Product Key	XWBAAC
GTIN	4055626673547
Weight per Piece (including packing)	2,343 g
Weight per Piece (excluding packing)	2,343 g
Customs tariff number	85444290
Country of origin	PL

# EV-T2G3C-3AC20A-8,0M2,5ESBK01 - AC charging cable



1051542

<https://www.phoenixcontact.com/pl/produkty/1051542>

## Technical Data

### Product properties

Product type	AC charging cable
Product family	CHARX connect comfort
Application	for charging electric vehicles (EV) with alternating current (AC) via type 2 vehicle charging inlets for installation at charging stations for electromobility (EVSE)
Type	AC charging cable with vehicle charging connector and open cable end
Design	with protective cap
Locking type	No locking option for U-lock
Affixed logo	PHOENIX CONTACT logo
Charging mode	Mode 3, Case C
Charging standard	Type 2

### Electrical properties

Type of signal transmission	Pulse width modulation
Note on the connection method	Crimp connection, cannot be disconnected
Coding	680 $\Omega$ (between PE and PP)
Type of charging current	AC 3-phase
Charging power	16.63 kW
Charging current	20 A

### Power contact

Number	5 (L1, L2, L3, N, PE)
Rated voltage	480 V AC
Rated current	20 A

### Signal contact

Number	2 (CP, PP)
Rated voltage	30 V AC
Rated current	2 A

### Dimensions

#### Vehicle charging connector

Width	70 mm
Height	137 mm
Depth	215.9 mm

### Material specifications

Color (Housing)	black (9005) gray (7042) black (9005)
-----------------	---

# EV-T2G3C-3AC20A-8,0M2,5ESBK01 - AC charging cable



1051542

<https://www.phoenixcontact.com/pl/produkty/1051542>

Material (Vehicle charging connector)	black (9005)
	black (9005)
	Plastic
	TPE-U
	Silver

## Cable/line

Cable length	8 m
Wiring standards/regulations	prEN 50620 / DIN EN 50620
Wiring certifications	VDE
Cable weight	max. 250 kg/km
Cable type	Class 5
Cable type	straight
Cable structure	5 x 2.5 mm <sup>2</sup> + 1 x 0.5 mm <sup>2</sup>
External cable diameter	12.8 mm ±0.4 mm
Outer sheath, material	TPE-U
Stripping length of the sheath	70 mm ±5 mm
Cable resistance	≤ 0.00798 Ω/m (based on a power core, at an ambient temperature of 20°C)
Bending radius	min. 192 mm (15x diameter)

## Mechanical properties

### Mechanical data

Insertion/withdrawal cycles	> 10000
Insertion force	< 100 N
Withdrawal force	< 100 N

## Environmental and real-life conditions

### Ambient conditions

Degree of protection Vehicle charging connector	IP44 (plugged in; when plugged in and ready to operate, the degree of protection is only ensued if both plug-in components are original products from Phoenix Contact or suitable standard-compliant products)
	IP54
Ambient temperature (operation)	-40 °C ... 50 °C
Ambient temperature (storage/transport)	-40 °C ... 80 °C
Altitude	5000 m (above sea level)

## Standards and regulations

### Connection in accordance with standard

Normative cable length restrictions	NOTE: Cable management may be required. Cable management is required in the US if the cable length exceeds 7.5 m (IEC 61851-1).
-------------------------------------	--

### Standards

# EV-T2G3C-3AC20A-8,0M2,5ESBK01 - AC charging cable



1051542

<https://www.phoenixcontact.com/pl/produkty/1051542>

Standards/regulations

IEC 62196-2

# EV-T2G3C-3AC20A-8,0M2,5ESBK01 - AC charging cable

1051542

<https://www.phoenixcontact.com/pl/produkty/1051542>

## Drawings

Schematic diagram

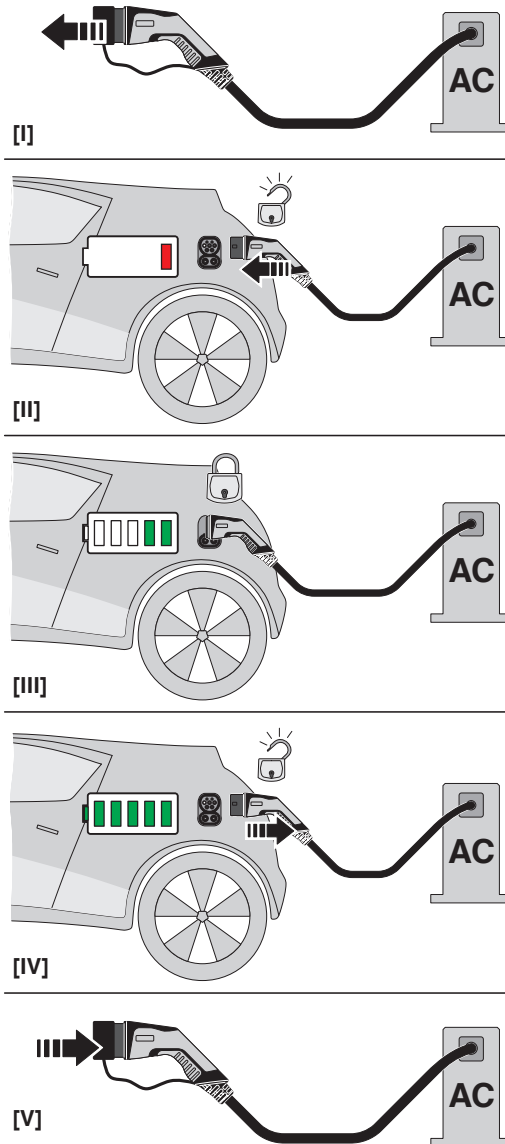

Operating instructions

# EV-T2G3C-3AC20A-8,0M2,5ESBK01 - AC charging cable

1051542

<https://www.phoenixcontact.com/pl/produkty/1051542>

Schematic diagram

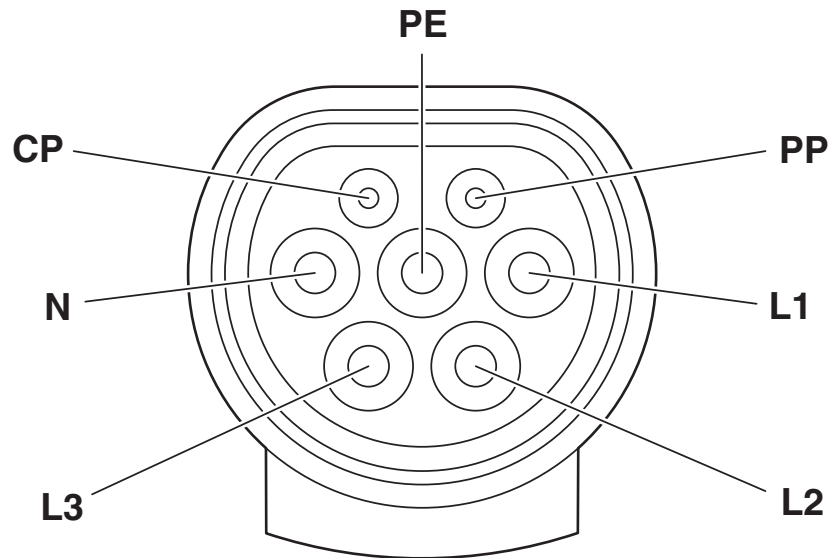

Pin assignment of the Vehicle Connector

Schematic diagram

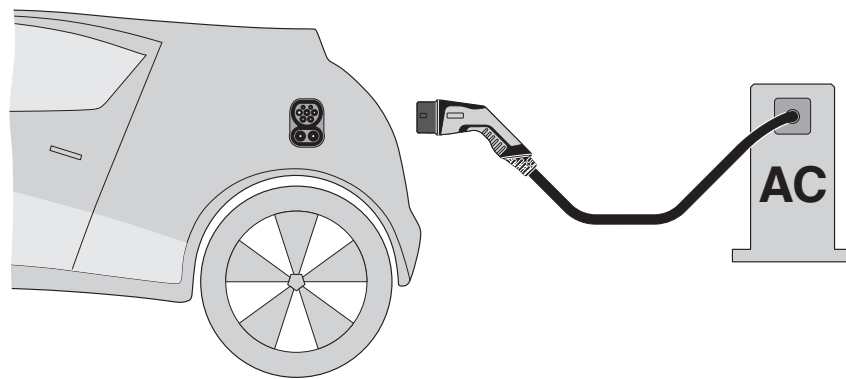

Terminology definition

# EV-T2G3C-3AC20A-8,0M2,5ESBK01 - AC charging cable



1051542

<https://www.phoenixcontact.com/pl/produkty/1051542>

Dimensional drawing

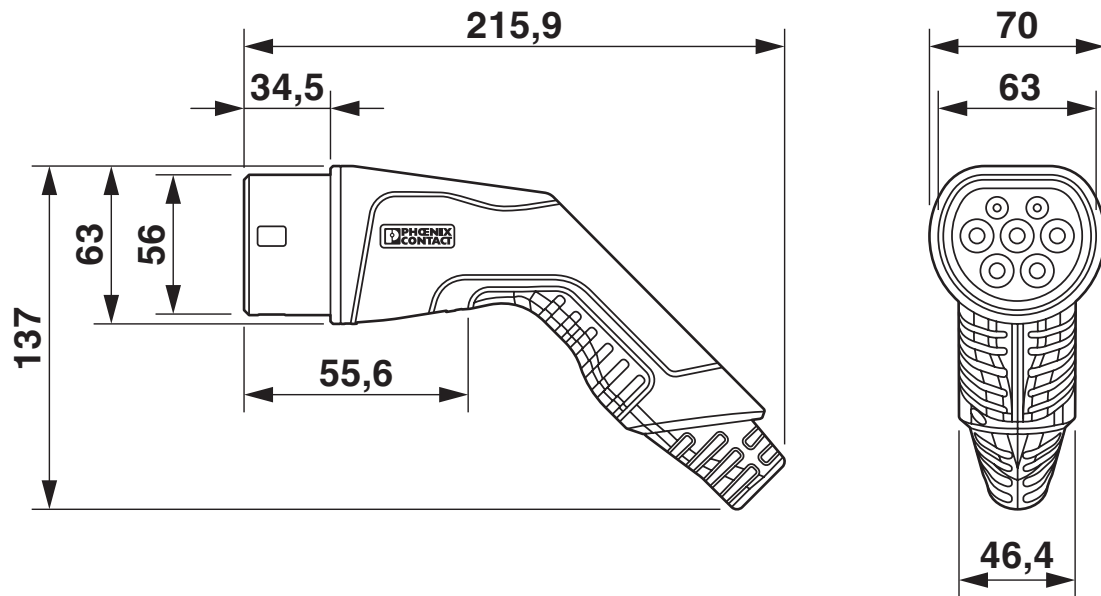

Make sure that the vehicle charging connector is placed in an appropriate charging connector holder, which ensures a minimum protection rating of IP24 in accordance with IEC 61851-1, for the entire time between charging. To create this charging connector holder, use the dimensions of the vehicle charging connector. Detailed dimensions can also be found in the Download area.

# EV-T2G3C-3AC20A-8,0M2,5ESBK01 - AC charging cable



1051542

<https://www.phoenixcontact.com/pl/produkty/1051542>

## Approvals

 <b>IECEE CB Scheme</b> Approval ID: DE1-65898/M1	Nominal Voltage $U_N$	Nominal Current $I_N$	Cross Section AWG	Cross Section $\text{mm}^2$
	480 V	20 A	-	-

 <b>VDE Zeichengenehmigung</b> Approval ID: 40045387	Nominal Voltage $U_N$	Nominal Current $I_N$	Cross Section AWG	Cross Section $\text{mm}^2$
	480 V	20 A	-	-



# EV-T2G3C-3AC20A-8,0M2,5ESBK01 - AC charging cable



1051542

<https://www.phoenixcontact.com/pl/produkty/1051542>

## Classifications

### ECLASS

ECLASS-9.0	27144705
ECLASS-10.0.1	27144705
ECLASS-11.0	27144705

### ETIM

ETIM 8.0	EC002897
----------	----------

### UNSPSC

UNSPSC 21.0	39121500
-------------	----------

# EV-T2G3C-3AC20A-8,0M2,5ESBK01 - AC charging cable



1051542

<https://www.phoenixcontact.com/pl/produkty/1051542>

## Environmental Product Compliance

REACH SVHC	Lead 7439-92-1
China RoHS	Environmentally Friendly Use Period = 10;
	For information on hazardous substances, refer to the manufacturer's declaration available under "Downloads"

# EV-T2G3C-3AC20A-8,0M2,5ESBK01 - AC charging cable



1051542

<https://www.phoenixcontact.com/pl/produkty/1051542>

## Accessories

### EV-T2AC-PARK - Charging connector holder

1624148

<https://www.phoenixcontact.com/pl/produkty/1624148>



CHARX connect, Charging connector holder, Accessories, for vehicle charging connectors on charging stations (EVSE), Type 2, IEC 62196-2, Front mounting, housing: black, PHOENIX CONTACT logo

---

### EV-LABEL-C - Label

1309766

<https://www.phoenixcontact.com/pl/produkty/1309766>



CHARX connect, Label, Accessories, for AC type 2 vehicle charging connector, DIN EN 17186

# EV-T2G3C-3AC20A-8,0M2,5ESBK01 - AC charging cable

1051542

<https://www.phoenixcontact.com/pl/produkty/1051542>

## CHARX SEC-1000 - AC charging controller

1139034

<https://www.phoenixcontact.com/pl/produkty/1139034>



CHARX control modular, AC charging controller, IEC 61851-1, operating mode: Stand-Alone, Client, interface: CHARX control modular system bus, Connectable peripheral devices: Energy meter, RFID, DC residual current detection, DIN rail mounting

---

## CHARX SEC-3000 - AC charging controller

1139022

<https://www.phoenixcontact.com/pl/produkty/1139022>



CHARX control modular, AC charging controller, with Embedded Linux system, IEC 61851-1, operating mode: Stand-Alone, Client, Server, interface: Ethernet (2 x), CHARX control modular system bus, MICRO-USB type C, communication protocol: OCPP 1.6J, Modbus/TCP, MQTT, Connectable peripheral devices: Energy meter, RFID, DC residual current detection, DIN rail mounting

# EV-T2G3C-3AC20A-8,0M2,5ESBK01 - AC charging cable



1051542

<https://www.phoenixcontact.com/pl/produkty/1051542>

## CHARX SEC-3050 - AC charging controller

1139018

<https://www.phoenixcontact.com/pl/produkty/1139018>



CHARX control modular, AC charging controller, with Embedded Linux system, IEC 61851-1, ISO 15118, operating mode: Stand-Alone, Client, Server, interface: Ethernet (2x), CHARX control modular system bus, MICRO-USB type C, communication protocol: OCPP 1.6J, Modbus/TCP, MQTT, Connectable peripheral devices: Energy meter, RFID, DC residual current detection, DIN rail mounting

---

## CHARX SEC-3100 - AC charging controller

1139012

<https://www.phoenixcontact.com/pl/produkty/1139012>



CHARX control modular, AC charging controller, with Embedded Linux system, IEC 61851-1, operating mode: Stand-Alone, Client, Server, interface: Ethernet (2 x), Cellular communication (4G/2G), CHARX control modular system bus, MICRO-USB type C, communication protocol: OCPP 1.6J, Modbus/TCP, MQTT, Connectable peripheral devices: Energy meter, RFID, DC residual current detection, DIN rail mounting

# EV-T2G3C-3AC20A-8,0M2,5ESBK01 - AC charging cable



1051542

<https://www.phoenixcontact.com/pl/produkty/1051542>

## CHARX SEC-3150 - AC charging controller

1138965

<https://www.phoenixcontact.com/pl/produkty/1138965>



CHARX control modular, AC charging controller, with Embedded Linux system, IEC 61851-1, ISO 15118, operating mode: Stand-Alone, Client, Server, interface: Ethernet (2x), Cellular communication (4G/2G), CHARX control modular system bus, MICRO-USB type C, communication protocol: OCPP 1.6J, Modbus/TCP, MQTT, Connectable peripheral devices: Energy meter, RFID, DC residual current detection, DIN rail mounting

---

## EEM-EM357 - Measuring instrument

2908588

<https://www.phoenixcontact.com/pl/produkty/2908588>



Three-phase power meter for active power measurement with direct measurement in networks of up to 500 V / 80 A, with S0 output, with digital input and RS-485 interface, certified in accordance with the MID directive

# EV-T2G3C-3AC20A-8,0M2,5ESBK01 - AC charging cable

1051542

<https://www.phoenixcontact.com/pl/produkty/1051542>

## EV-CC-AC1-M3-CC-SER-HS - AC charging controller

1622459

<https://www.phoenixcontact.com/pl/produkty/1622459>



The EV-CC-AC1-M3-CBC-SER-HS charging controller with housing for DIN rail mounting is used for charging electric vehicles at 3-phase AC networks according to IEC 61851-1, Mode 3. Optimized for charging stations with permanently mounted Vehicle Connector. All charging functions and comprehensive configuration settings are already integrated.

---

## EV-CC-AC1-M3-CC-SER-PCB - AC charging controller

1622460

<https://www.phoenixcontact.com/pl/produkty/1622460>



The EV-CC-AC1-M3-CC-SER-PCB charging controller as a PCB for charging electric vehicles on a 3-phase AC power grid according to IEC 61851-1, Mode 3. Optimized for charging stations with permanently mounted Vehicle Connector. All charging functions and comprehensive configuration settings are already integrated.

# EV-T2G3C-3AC20A-8,0M2,5ESBK01 - AC charging cable

1051542

<https://www.phoenixcontact.com/pl/produkty/1051542>

## EV-CC-AC1-M3-CC-SER-PCB-XC-25X - AC charging controller

1627742

<https://www.phoenixcontact.com/pl/produkty/1627742>



The EV-CC-AC1-M3-CC-SER-PCB charging controller as a PCB for charging electric vehicles on a 3-phase AC power grid according to IEC 61851-1, Mode 3. Optimized for charging stations with permanently mounted Vehicle Connector. All charging functions and comprehensive configuration settings are already integrated.

---

## EV-CC-AC1-M3-CC-SER-PCB-MSTB - AC charging controller

1627367

<https://www.phoenixcontact.com/pl/produkty/1627367>



The EV-CC-AC1-M3-CC-SER-PCB-MSTB charging controller as a PCB for charging electric vehicles according to IEC 61851-1, Mode 3, optimized for charging stations with permanently mounted Vehicle Connector. Connection via PCB connector on header.



# EV-T2G3C-3AC20A-8,0M2,5ESBK01 - AC charging cable

1051542

<https://www.phoenixcontact.com/pl/produkty/1051542>

## EM-CP-PP-ETH - AC charging controller

2902802

<https://www.phoenixcontact.com/pl/produkty/2902802>



EV charge control is used to charge electrical vehicles on the 3-phase AC mains power supply according to IEC 61851-1 Mode 3. All necessary control functions are integrated. Additional functions are available for various charging applications.

---

## VAL-EV-T1/T2 264/12.5/3+1 - Lightning/surge arrester type 1/2

1180149

<https://www.phoenixcontact.com/pl/produkty/1180149>



CHARX protect advanced: Plug-in lightning surge/surge protective device, in accordance with Type 1/2 / Class I/II, for 3-phase power supply networks with separate N and PE (5-conductor system: L1, L2, L3, N, PE). Specifically designed for use in e-mobility.

# EV-T2G3C-3AC20A-8,0M2,5ESBK01 - AC charging cable

1051542

<https://www.phoenixcontact.com/pl/produkty/1051542>

## VAL-EV-T1/T2 264/12.5/3+1-R - Lightning/surge arrester type 1/2

1180150

<https://www.phoenixcontact.com/pl/produkty/1180150>



CHARX protect advanced: Plug-in lightning surge/surge protective device, in accordance with Type 1/2 / Class I/II, for 3-phase power supply networks with separate N and PE (5-conductor system: L1, L2, L3, N, PE), with remote indication contact. Specifically designed for use in e-mobility.

---

## VAL-EV-T2 280/3+1 - Type 2 surge arrester

1180144

<https://www.phoenixcontact.com/pl/produkty/1180144>



CHARX protect basic: Plug-in surge protective device, in accordance with Type 2/Class II, for 3-phase power supply networks with separate N and PE (5-conductor system: L1, L2, L3, N, PE). Specifically designed for use in e-mobility.

# EV-T2G3C-3AC20A-8,0M2,5ESBK01 - AC charging cable



1051542

<https://www.phoenixcontact.com/pl/produkty/1051542>

## VAL-EV-T2 280/3+1-R - Type 2 surge arrester

1180145

<https://www.phoenixcontact.com/pl/produkty/1180145>



CHARX protect basic: Plug-in surge protective device, in accordance with Type 2/Class II, for 3-phase power supply networks with separate N and PE (5-conductor system: L1, L2, L3, N, PE), with remote indication contact. Specifically designed for use in e-mobility.

---

## G-INS-M20-M68N-PNES-BK - Cable gland

1424481

<https://www.phoenixcontact.com/pl/produkty/1424481>



Cable gland, material for screw connection: PA, external cable diameter 10 mm .  
.. 14 mm, shielding: no, connecting thread: M20 x 1.5, color: jet black RAL 9005

---

Phoenix Contact 2023 © - all rights reserved  
<https://www.phoenixcontact.com>

PHOENIX CONTACT Sp. z o.o.  
ul. Bierutowska 57-59, Budynek nr 3/A  
51-317 Wrocław  
71/ 39 80 410  
[pxcpl@phoenixcontact.pl](mailto:pxcpl@phoenixcontact.pl)

## X-ON Electronics

Largest Supplier of Electrical and Electronic Components

*Click to view similar products for [Specialised Cables category](#):*

*Click to view products by [Phoenix Contact manufacturer](#):*

Other Similar products are found below :

[706000D02F200](#) [910640](#) [96CB-L2020PIB2](#) [AC172](#) [ACL-SSI-4](#) [1300150047](#) [1300660036](#) [1300660042](#) [1302260080](#) [1300150079](#)  
[1300220119](#) [1301240492](#) [1365323-1](#) [1589946-2](#) [1971465-2](#) [20240400003](#) [20886510030](#) [2-22733-8](#) [3011-03](#) [SSM005PCODY012Q](#) [CCS-](#)  
[FCB-5](#) [CCSFCBF2](#) [VMMP6R](#) [427492400-3](#) [05AD05X](#) [10075358-F0200YYLF](#) [1052015-1-10](#) [540012](#) [RTPADPTR02](#) [636083-1](#) [83010-](#)  
[0157](#) [VMMP2BK](#) [VMMP1BK](#) [ENP2205M030](#) [5-1589943-0](#) [N12601](#) [1300660038](#) [1300150101](#) [1300140041](#) [1300660049](#) [1300300014](#)  
[1300150058](#) [1300150050](#) [1300150031](#) [1300140064](#) [1200900023](#) [00-4951](#) [XW2Z100JF1](#) [1200900047](#) [C200H-CN220-EU](#)