

STEP3-PS/1AC/24DC/0.63/PT

Power supply unit

Data sheet
109397_en_00

© PHOENIX CONTACT 2020-04-15



1 Description

The STEP POWER power supplies with Push-in connection technology are the professional solution for intelligent building automation. The compact devices are economical, space-saving, and flexible in application.

Features

- Device design for use in surface-mounted or flush-mounted distributors (VDE 0603-1, DIN 43871)
- Energy savings with the highest level of efficiency in no-load and part-load operation (Efficiency Level VI)
- Space savings in the control cabinet due to the narrow design combined with increased performance (up to 100%)
- Can be used throughout the world, thanks to the wide range input and comprehensive international approval package
- Approval for household purposes (DIN EN 60335-1) allows use in domestic applications
- Quick and easy startup with tool-free Push-in connection technology at a 45° angle with double terminal points
- Flexible assembly – can be snapped onto the DIN rail or screwed onto a level surface

Technical data (short form)

Input voltage range	100 V AC ... 240 V AC -15 % ... +10 % 110 V DC ... 250 V DC -20 % ... +40 %
Mains buffering	typ. 20 ms (120 V AC) typ. 90 ms (230 V AC)
Nominal output voltage (U_N)	24 V DC
Nominal output current (I_N)	0.63 A
Output power (P_N)	15 W
Efficiency Level	VI
Efficiency (for nominal values)	> 86 % (120 V AC) > 87 % (230 V AC)
Residual ripple	typ. 100 mV _{pp}
MTBF (IEC 61709, SN 29500)	> 3500000 h (25 °C) > 1800000 h (40 °C) > 1200000 h (50 °C)
Ambient temperature (operation)	-10 °C ... 70 °C (Derating: > 50 °C; 2 %/K)
Startup type tested	-25 °C
Dimensions W/H/D	18 mm / 90 mm / 55 mm
Horizontal pitch (DIN 43880)	1 Div.
Weight	70 g



All technical specifications are nominal and refer to a room temperature of 25 °C and 70% relative humidity at 100 m above sea level.

2 Table of contents

1	Description	1
2	Table of contents	2
3	Ordering data	4
4	Technical data	4
5	Safety and installation notes	11
6	High-voltage test (HIPOT)	12
6.1	High-voltage dielectric test (dielectric strength test)	12
6.2	High-voltage dielectric test during the manufacturing process	12
6.3	High-voltage dielectric test performed by the customer	12
6.3.1	Performing high-voltage testing	12
7	Design	13
7.1	Rating plate	13
7.2	Device connections and functional elements	13
7.3	Block diagram	14
7.4	Device dimensions	15
8	Mounting/remove	15
8.1	Convection	15
8.2	Mounting position	16
8.3	Installation height	16
8.4	Keep-out areas	16
8.5	Mounting the power supply unit	17
8.5.1	Mounting on a DIN rail (integrated snap-on foot)	17
8.5.2	Screw fixing to the mounting surface (mounting flanges)	17
8.6	Removing the power supply unit	18
8.6.1	DIN rail end mounting (integrated snap-on foot)	18
8.6.2	Removal from the mounting surface (mounting flanges)	18
9	Device connection terminal blocks	19
9.1	AC input terminal blocks	19
9.2	Primary side connection and fuse protection	19
9.2.1	1AC supply network	19
9.2.2	3AC supply network	19
9.2.3	DC supply network	20
9.3	DC output terminal blocks	20
9.3.1	Wiring principle for DC output terminals	20
9.3.2	Protection of the secondary side	20
10	Function elements	21
10.1	Display element – DC OK LED	21
11	Output characteristic curves	21

12	Connection versions	22
12.1	Increasing power	22
12.1.1	Series operation	22
12.1.2	Parallel operation	22
12.2	Redundant operation	22
12.3	Fundamental prerequisites for parallel operation (power increase, redundancy operation)	23
13	Derating	23
13.1	Ambient temperature	23
13.2	Installation height	23
13.3	Position-dependent derating	24
13.3.1	Normal mounting position	24
13.3.2	Rotated mounting position 90° Z-axis	24
13.3.3	Rotated mounting position 180° Z-axis	25
13.3.4	Rotated mounting position 270° Z-axis	25
13.3.5	Rotated mounting position 90° X-axis	26
13.3.6	Rotated mounting position 270° X-axis	26
14	Application example	27
14.1	Power supply in a surface-mounted or flush-mounted distributor	27
15	Disposal and recycling	27

3 Ordering data

Description	Type	Order No.	Pcs./Pkt.
Primary-switched power supply unit, STEP POWER, Push-in technology, DIN rail mounting, input: 1-phase, output: 24 V DC / 0.63 A	STEP3-PS/1AC/24DC/0.63/PT	1088495	1
Accessories	Type	Order No.	Pcs./Pkt.
Redundancy module, 5 ... 24 V DC, 2x 5 A, 1x 10 A	STEP-DIODE/5-24DC/2X5/1X10	2868606	1



The range of accessories is being continuously extended. The current range of accessories can be found in the download area for the product.

4 Technical data

Input data	
	Unless otherwise stated, all data applies for 25°C ambient temperature, 230 V AC input voltage, and nominal output current (I_N).
Input voltage range	100 V AC ... 240 V AC -15 % ... +10 % 110 V DC ... 250 V DC -20 % ... +40 %
Frequency range (f_N)	50 Hz ... 60 Hz \pm 10 %
Network type	Star network
Current consumption	0.29 A (100 V AC) 0.16 A (240 V AC) 0.16 A (110 V DC) 0.07 A (250 V DC)
Discharge current to PE	< 0.25 mA
Mains buffering time	typ. 20 ms (120 V AC) typ. 90 ms (230 V AC)
Switch-on time	typ. 2 s
Inrush current	typ. 30 A (25 °C)
Inrush current integral (I^2t)	typ. 0.14 A ² s
	During the first few microseconds, the current flow into the filter capacitors is excluded.
	The SCCR (short-circuit current rating) value of the power supply unit corresponds to the SCCR value of the backup fuse.

Input protection , AC/DC (to be connected externally upstream)

Input current I_{IN} Input protection	Circuit breaker					Neozed fuse or equivalent	Power switch
	A	B	C	D	K		
Characteristics						gG	$\leq 13 \times I_{IN}$ (maximum magnetic tripping)
6 A	-	✓	✓	✓	✓	-	-
8 A	-	✓	✓	✓	✓	-	-
10 A	-	✓	✓	✓	✓	-	-
13 A	-	✓	✓	✓	✓	-	-
16 A	-	✓	✓	✓	✓	-	-
20 A	-	✓	✓	✓	✓	-	-

Protective circuit

Type of protection Transient surge protection

Protective circuit/component Varistor

Electric strength of the insulation

Housing

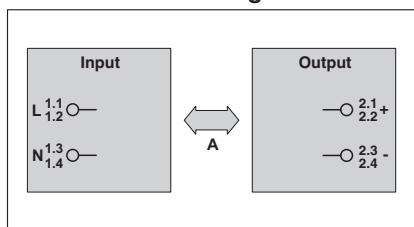

A

Type test (IEC/EN 61010-1:2010, section 6.8)

4 kV AC

Production test

3.75 kV AC

POWER factor

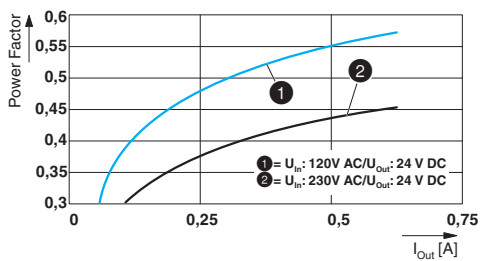

Crest factor

120 V AC

230 V AC

typ. 3,24

typ. 4.17

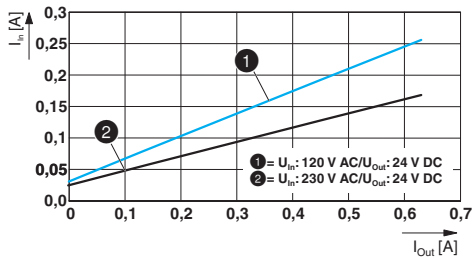
Input current vs. output current**Input connection data**

Connection method	Push-in technology
Stripping length	10 mm
Conductor cross section, solid	0.2 mm ² ... 2.5 mm ²
Conductor cross section, flexible	0.2 mm ² ... 2.5 mm ²
Conductor cross section flexible, with ferrule with plastic sleeve	0.2 mm ² ... 1 mm ²
Conductor cross section flexible, with ferrule without plastic sleeve	0.5 mm ² ... 2.5 mm ²
Conductor cross section AWG (Cu)	24 ... 14

Output data

Nominal output voltage (U_N)	24 V DC
Nominal output current (I_N)	0.63 A
Control deviation	< 0.5 % (Static load change 10 % ... 90 %) < 4 % (Dynamic load change 10 % ... 90 %, (10 Hz)) < 0.1 % (change in input voltage ± 10 %)
Short-circuit-proof	yes
No-load proof	yes
Residual ripple	typ. 100 mV _{PP}
Connection in parallel	yes, for increasing power and redundancy with diode
Connection in series	yes, for increased efficiency
Feedback voltage resistance	$\leq 35 \text{ V DC}$
Protection against overvoltage at the output (OVP)	< 35 V DC
Rise time	typ. 100 ms ($U_{Out} = 10 \text{ % ... 90 \text{ %}}$)

Output connection data

Connection method	Push-in technology
Stripping length	10 mm
Conductor cross section, solid	0.2 mm ² ... 2.5 mm ²
Conductor cross section, flexible	0.2 mm ² ... 2.5 mm ²
Conductor cross section flexible, with ferrule with plastic sleeve	0.2 mm ² ... 1 mm ²
Conductor cross section flexible, with ferrule without plastic sleeve	0.5 mm ² ... 2.5 mm ²
Conductor cross section AWG (Cu)	24 ... 14

LED signaling

$U_{Out} > 0,9 \times U_N$ ($U_N = 24$ V DC)	LED lights up green
$U_{Out} < 0,9 \times U_N$ ($U_N = 24$ V DC)	LED off

Reliability

MTBF (IEC 61709, SN 29500)	230 V AC
	> 3500000 h (25 °C)
	> 1800000 h (40 °C)
	> 1200000 h (50 °C)

General data

Degree of protection	IP20
Protection class	II (in closed control cabinet)
Efficiency Level	VI
Flammability rating UL 94	V0 (Housing, terminal blocks, base latches)
Housing material	Polycarbonate
Foot latch material	Polyamid
Dimensions W / H / D (state of delivery)	18 mm / 90 mm / 55 mm
Horizontal pitch	1 Div. (DIN 43880)
Weight	70 g

Power dissipation

	120 V AC	230 V AC
No load	< 0.1 W	< 0.1 W
Nominal load	< 2.5 W	< 2.3 W

Efficiency

	120 V AC	230 V AC
	> 86 % (120 V AC)	> 86.7 % (230 V AC)

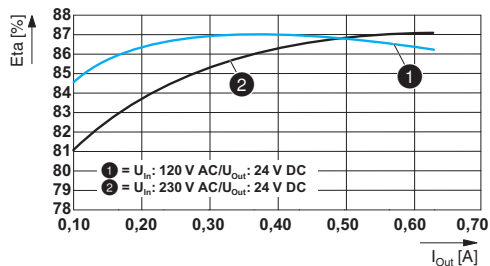

Ambient conditions

Ambient temperature (operation) -10 °C ... 70 °C (Derating: > 50 °C; 2 %/K)



The ambient temperature (operation) refers to IEC 61010 surrounding air temperature.

Ambient temperature (start-up type tested) -25 °C

Ambient temperature (storage/transport) -40 °C ... 85 °C

Max. permissible relative humidity (operation) ≤ 95 % (at 25 °C, non-condensing)

Installation height ≤ 4000 m (> 2000 m, Derating: 10 %/1000 m)

Vibration (operation) < 15 Hz, amplitude ±2.5 mm (according to IEC 60068-2-6)
15 Hz ... 150 Hz, 2.3g, 90 min.

Shock 18 ms, 30g, in each space direction (according to IEC 60068-2-27)

Degree of pollution 2

Climatic class 3K3 (EN 60721)

Overvoltage category

EN 61010-1 II (≤ 4000 m)

EN 62477-1 III (≤ 2000 m)

Standards

Electrical safety IEC 61010-1 (SELV)

Safety extra-low voltage IEC 61010-1 (SELV)
IEC 61010-2-201 (PELV)

Safe isolation IEC 61558-2-16

Low-voltage power supplies, DC output EN 61204-3

Safety requirements for electrical equipment for measurement, control, and laboratory use IEC 61010-1

Safety of electrical devices for household use and similar purposes DIN EN 60335-1

Approvals

UL UL 1310 Class 2 Power Units
UL/C-UL Listed UL 61010-1
UL/C-UL Listed UL 61010-2-201
UL/C-UL Listed ANSI/UL 121201 Class I, Division 2, Groups A, B, C, D (Hazardous Location)

Temperature class (ANSI/UL 121201)

Temp code T4 (-10...+70 °C; >50 °C, Derating: 2 %/K)



Current approvals/permissions for the product can be found in the download area under phoenixcontact.net/products

Electromagnetic compatibility		
Conformance with EMC Directive 2014/30/EU		
Noise emission according to EN 61000-6-3 (residential and commercial) and EN 61000-6-4 (industrial)		
CE basic standard	Minimum normative requirements	Higher requirements in practice (covered)
Conducted noise emission EN 55016	EN 61000-6-4 (Class A)	EN 61000-6-3 (Class B)
Noise emission EN 55016	EN 61000-6-4 (Class A)	EN 61000-6-3 (Class B)
Harmonic currents EN 61000-3-2	not required	EN 61000-3-2 (Class A)
Flicker EN 61000-3-3	not required	0 kHz ... 2 kHz
EN 61000-6-2:2005		
CE basic standard	Minimum normative requirements of EN 61000-6-2 (CE) (immunity for industrial environments)	Higher requirements in practice (covered)
Electrostatic discharge EN 61000-4-2		
Housing contact discharge	4 kV (Test Level 2)	6 kV (Test Level 3)
Housing air discharge	8 kV (Test Level 3)	8 kV (Test Level 3)
Comments	Criterion B	Criterion A
Electromagnetic HF field EN 61000-4-3		
Frequency range	80 MHz ... 1 GHz	80 MHz ... 1 GHz
Test field strength	10 V/m (Test Level 3)	10 V/m (Test Level 3)
Frequency range	1.4 GHz ... 6 GHz	1 GHz ... 6 GHz
Test field strength	3 V/m (Test Level 2)	10 V/m (Test Level 3)
Comments	Criterion A	Criterion A
Fast transients (burst) EN 61000-4-4		
Input	asymmetrical 2 kV (Test Level 3)	asymmetrical 4 kV (Test Level 4)
Output	asymmetrical 1 kV (Test Level 2)	asymmetrical 2 kV (Test Level 3)
Comments	Criterion B	Criterion A
Surge voltage load (surge) EN 61000-4-5		
Input	symmetrical 1 kV (Test Level 3) asymmetrical 2 kV (Test Level 3)	symmetrical 2 kV (Test Level 4) asymmetrical 4 kV (Test Level 4)
Output	symmetrical 0.5 kV (Test Level 2) asymmetrical 1 kV (Test Level 2)	symmetrical 1 kV (Test Level 3) asymmetrical 2 kV (Test Level 3)
Comments	Criterion B	Criterion A

EN 61000-6-2:2005			
CE basic standard		Minimum normative requirements of EN 61000-6-2 (CE) (immunity for industrial environments)	Higher requirements in practice (covered)
Conducted interference EN 61000-4-6			
	Input/output	asymmetrical	asymmetrical
	Frequency range	0.15 MHz ... 80 MHz	0.15 MHz ... 80 MHz
	Voltage	10 V (Test Level 3)	10 V (Test Level 3)
	Comments	Criterion A	Criterion A
Voltage dips EN 61000-4-11			
Input voltage (230 V AC , 50 Hz)			
	Voltage dip	70 % , 25 periods (Class 3)	70 % , 25 periods (Class 3)
	Comments	Criterion C	Criterion A
	Voltage dip	40 % , 10 periods (Class 3)	40 % , 10 periods (Class 3)
	Comments	Criterion C	Criterion A
	Voltage dip	0 % , 1 period (Class 3)	0 % , 1 period (Class 3)
	Comments	Criterion B	Criterion A

Key

Criterion A	Normal operating behavior within the specified limits.
Criterion B	Temporary impairment to operational behavior that is corrected by the device itself.
Criterion C	Temporary adverse effects on the operating behavior, which the device corrects automatically or which can be restored by actuating the operating elements.

5 Safety and installation notes

Symbols used

Instructions and possible hazards are indicated by corresponding symbols in this document.



This is the safety alert symbol. It is used to alert you to potential personal injury hazards. Obey all safety measures that follow this symbol to avoid possible personal injuries.

There are different categories of personal injury that are indicated by a signal word.



WARNING

This indicates a hazardous situation which, if not avoided, could result in death or serious injury.



CAUTION

This indicates a hazardous situation which, if not avoided, could result in minor or moderate injury.

The following symbols are used to indicate potential damage, malfunctions, or more detailed sources of information.



NOTE

This symbol together with the signal word NOTE and the accompanying text alert the reader to a situation which may cause damage or malfunction to the device, hardware/software, or surrounding property.



This symbol and the accompanying text provide the reader with additional information or refer to detailed sources of information.

Safety notes and warning instructions



WARNING: Danger to life by electric shock!

- Only skilled persons may install, start up, and operate the device.
- Never carry out work when voltage is present.
- Establish connection correctly and ensure protection against electric shock.
- Cover termination area after installation in order to avoid accidental contact with live parts (e. g., installation in control cabinet).



NOTE

- Observe the national safety and accident prevention regulations.
- Assembly and electrical installation must correspond to the state of the art.
- The power supply is a built-in device and is designed for mounting in a control cabinet.
- The IP20 degree of protection of the device is intended for use in a clean and dry environment.
- Observe mechanical and thermal limits.
- Horizontal mounting position (normal mounting position)
- Mount the power supply unit in the standard installation position. Position of the L/N connection terminal blocks at bottom.
- Ensure that the primary-side wiring and secondary-side wiring are the correct size and have sufficient fuse protection.
- For the connection parameters for wiring the power supply, such as the required stripping length with and without ferrule, refer to the technical data section.
- Use copper cables for operating temperatures of >75 °C (ambient temperature <55 °C)
>90 °C (ambient temperature <75 °C).
- The power supply is approved for the connection to TN, TT and IT power grids (star networks) with a maximum phase-to-phase voltage of 240 V AC
- Protect the device against foreign bodies penetrating it, e.g., paper clips or metal parts.
- The power supply is maintenance-free. Repairs may only be carried out by the manufacturer. The warranty no longer applies if the housing is opened.
- The power supply may only be used for its intended use.

6 High-voltage test (HIPOT)

This protection class II power supply is subject to the Low Voltage Directive and is factory tested. During the HIPOT test (high-voltage test), the insulation between the input circuit and output circuit is tested for the prescribed electric strength values, for example. The test voltage in the high-voltage range is applied at the input and output terminal blocks of the power supply. The operating voltage used in normal operation is a lot lower than the test voltage used.



High-voltage tests can be performed as described.

The test voltage should rise and fall in ramp form. The relevant rise and fall time of the ramp should be at least two seconds.

6.1 High-voltage dielectric test (dielectric strength test)

In order to protect the user, power supplies (as electric components with a direct connection to potentially hazardous voltages) are subject to more stringent safety requirements. For this reason, permanent safe electrical isolation between the hazardous input voltage and the touch-proof output voltage as safety extra-low voltage (SELV) must always be ensured.

In order to ensure permanent safe isolation of the AC input circuit and DC output circuit, high-voltage testing is performed as part of the safety approval process (type test) and manufacturing (routine test).

6.2 High-voltage dielectric test during the manufacturing process

During the power supply manufacturing process, a high-voltage test is performed as part of the dielectric test in accordance with the specifications of IEC/UL/EN 61010-1. Routine manufacturing tests are inspected regularly by a certification authority.

6.3 High-voltage dielectric test performed by the customer

Apart from routine and type tests to guarantee electrical safety, the end user does not have to perform another high-voltage test on the power supply as an individual component. According to EN 60204-1 (Safety of machinery - Electrical equipment of machines) the power supply can be disconnected during the high-voltage test and only installed once the high-voltage test has been completed.

6.3.1 Performing high-voltage testing

If high-voltage testing of the control cabinet or the power supply as a stand-alone component is planned during final inspection and testing, the following features must be observed.

- The power supply wiring must be implemented as shown in the wiring diagram.
- The maximum permissible test voltages must not be exceeded.

Avoid unnecessary loading or damage to the power supply due to excessive test voltages.



For the relevant applicable test voltages and insulation distances, refer to the corresponding table (see technical data: electric strength of the insulation section).

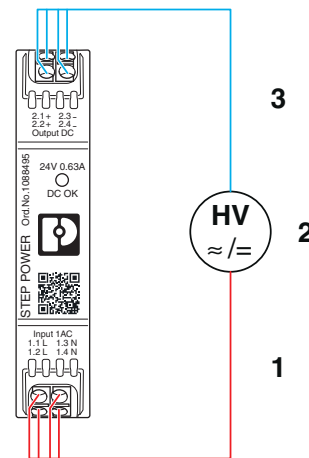

Figure 1 Potential-related wiring for the high-voltage test

Key

No.	Designation	Color coding	Potential levels
1	AC input circuit	Red	Potential 1
2	High-voltage tester	--	--
3	DC output circuit	Blue	Potential 2

7 Design

7.1 Rating plate

In accordance with the German Product Safety Law (ProdSG) it is only permissible to make such products available on the market if they meet certain safety standards. It must be ensured at all times that users are not exposed to hazards.

In accordance with ProdSG, every device must therefore be fitted with a rating plate. All relevant information on the safe use of the device must also be included.



The power supply device rating plate is located on the right-hand side of the housing (as viewed from the front).

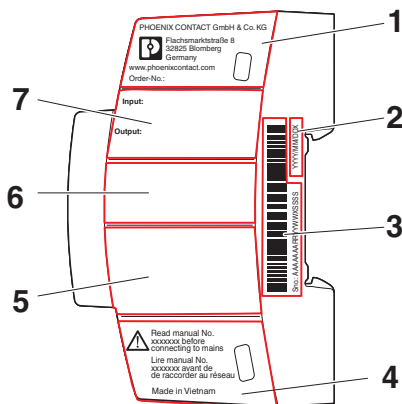

Figure 2 Rating plate information

Key

No.	Designation
1	Identification of the provider
2	Date of manufacture
3	Bar code and serial number for device identification
4	Designation of product-related device documentation
5	Device approvals
6	Ambient conditions
7	Device connection data

7.2 Device connections and functional elements

Device connections are labeled with connection tags to ensure clear and definitive identification.

The connection tags are split into the following connection levels:

Connection level	Description
1.x	Input
2.x	Output

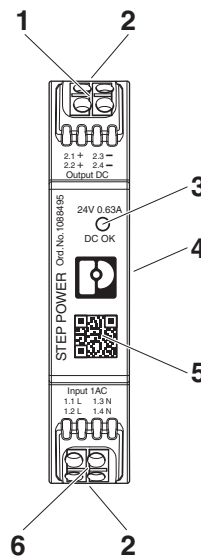

Figure 3 Location of functional elements and device connections

Key

No.	Designation	Connection labeling
1	Connection terminal block output voltage: Output DC +/-	2.1 ... 2.4
2	Mounting flange for wall mounting (back of device)	--
3	Signaling DC OK LED	--
4	Integrated snap-on foot for DIN rail mounting (back of device)	--
5	QR code web link	--
6	Connection terminal block input voltage: Input L/N	1.1 ... 1.4

7.3 Block diagram

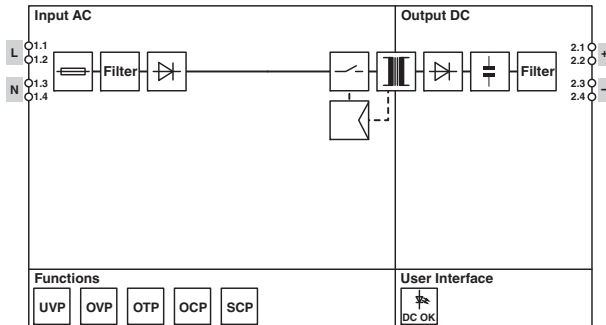

Figure 4 Block diagram

Key

Symbol	Designation – Input AC, Output DC
	Input fuse, internal device protection
	EMC filter
	Rectification
	Switching transistor
	Transmitter with electrical isolation
	Smoothing capacitor
	Control equipment

Symbol	Designation – Functions
	Undervoltage protection protects the AC input of the power supply against damage in the event of an AC undervoltage.
	Overvoltage protection protects the DC output of the power supply and the connected load against damage in the event of an overvoltage
	Overtemperature protection protects the power supply against damage in the event of impermissibly high intrinsic external heating.
	Overcurrent protection protects the DC output of the power supply against damage in the event of an impermissibly high current load.
	Short-circuit protection protects the DC output of the power supply against damage in the vent of an output-side short circuit.

Symbol	Designation – User interface
	DC OK LED, indicates the operating status of the power supply

7.4 Device dimensions

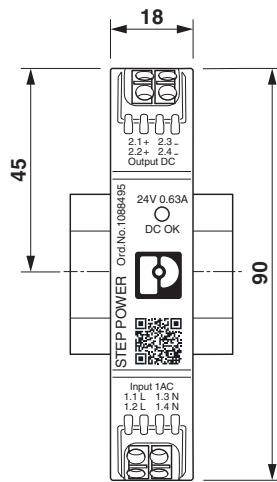

Figure 5 Device dimensions (dimensions in mm)

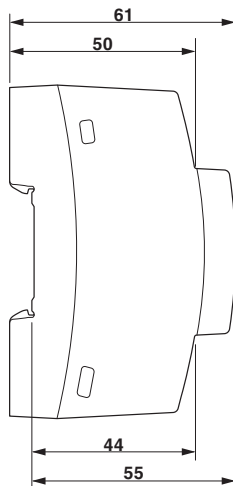

Figure 6 Device dimensions (dimensions in mm)

8 Mounting/remove

The fanless convection-cooled power supply can be snapped onto 35 mm DIN rails with a top hat profile (TH 35-7.5 / TH 35-15) in accordance with EN 60715.

8.1 Convection

To ensure sufficient convection, a minimum clearance is necessary between the power supply and above/below the installed devices. The minimum clearances are rated based on the standard mounting position with nominal power supply operation (see section: Restricted areas).

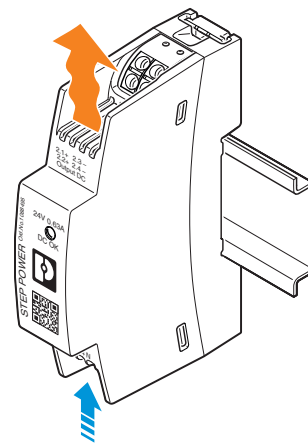

Figure 7 Schematic diagram of the convection cooling

8.2 Mounting position

The specified technical data for the power supply is based on nominal operation in the standard mounting position. Any different technical data based on deviating mounting positions or other ambient conditions is labeled accordingly (see section: Derating).

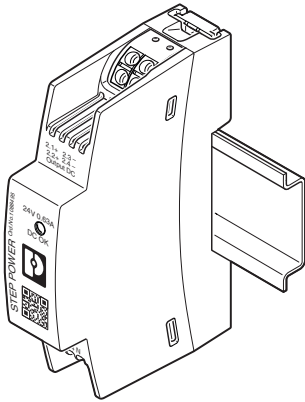

Figure 8 Power supply installed in the normal mounting position

8.3 Installation height

You can operate the power supply without power limitations up to an installation altitude of 2000 m. For altitudes higher than 2000 m, different specifications apply due to the differing air pressure and the reduced convection cooling associated with this (see section: Derating).

8.4 Keep-out areas

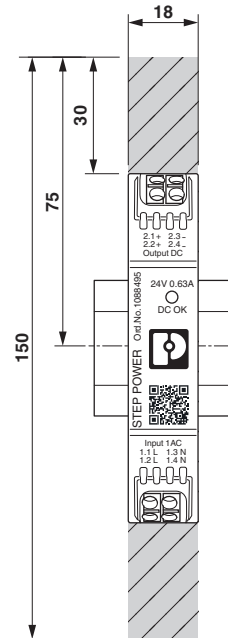

Figure 9 Device dimensions and minimum keep-out areas (in mm)

8.5 Mounting the power supply unit

8.5.1 Mounting on a DIN rail (integrated snap-on foot)

To mount the power supply on a DIN rail, proceed as follows:

1. In the standard mounting position, the power supply is mounted on the DIN rail from the front. When doing so, ensure that the snap-on foot rests completely on the DIN rail (A).
2. Then push the power supply onto the DIN rail until the snap-on foot audibly snaps into place (B).
3. Check that the power supply is securely attached to the DIN rail.

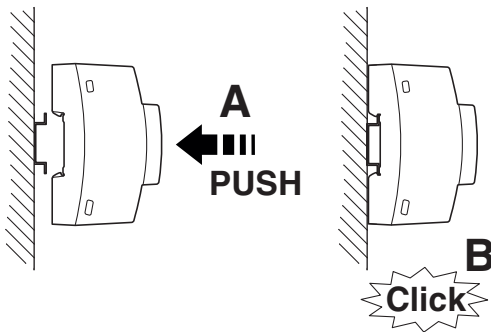

Figure 10 Snapping the power supply onto the DIN rail



The power supply housing has been designed so that it can also be mounted and operated in a surface-mounted or flush-mounted distributor in accordance with VDE 0603-1 or DIN 43871. The power supply is mounted via the integrated snap-on foot directly onto the DIN rail of the surface-mounted or flush-mounted distributor (see section: Application example).

8.5.2 Screw fixing to the mounting surface (mounting flanges)

To mount the power supply with screws directly on the mounting surface, proceed as follows:

1. Two M4 cylinder screws (DIN EN ISO 1207) are needed to screw-mount the power supply.
2. Drill two fixing holes with M4 threads and a hole clearance of 98 mm in the mounting location.
3. Push the mounting flanges (orange base latch) for fixing to the mounting surface upwards and downwards out of the housing base.
4. Screw the power supply onto the mounting surface using the two M4 cylinder screws.
5. Check that the power supply is securely attached to the mounting surface.

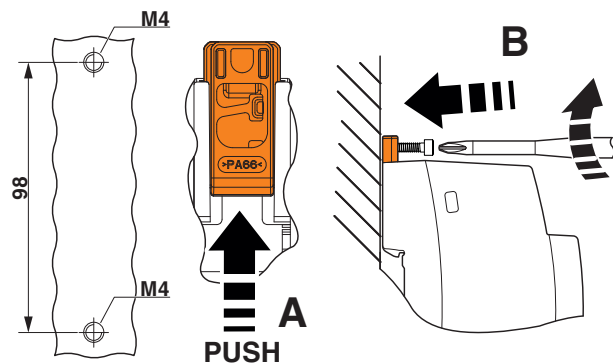

Figure 11 Screw fixing of the power supply to the mounting surface

8.6 Removing the power supply unit

8.6.1 DIN rail end mounting (integrated snap-on foot)

To remove the power supply from the DIN rail, proceed as follows:

1. Take a suitable screwdriver and insert it into the interlock opening on the snap-on foot.
2. Release the latch by levering the screwdriver downwards (A).
3. Carefully swivel the power supply downwards (B) and let the interlock slide back into the starting position.
4. Then lift the power supply from the DIN rail.

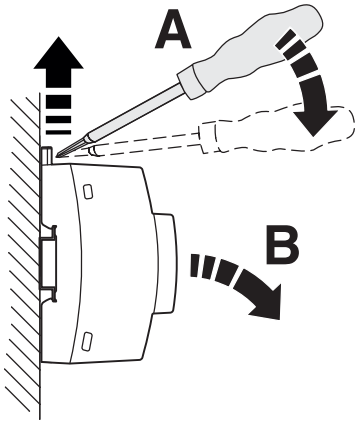

Figure 12 Removing the power supply from the DIN rail

8.6.2 Removal from the mounting surface (mounting flanges)



WARNING: Danger due to short circuit
When unscrewing and removing the M4 cylinder screws, ensure that none fall into your application.

To remove the power supply from the mounting surface, proceed as follows:

1. Unscrew one of the two M4 cylinder screws used to attach the power supply.
2. Remove the M4 cylinder screw.
3. Unscrew the second M4 cylinder screw and then remove the power supply.

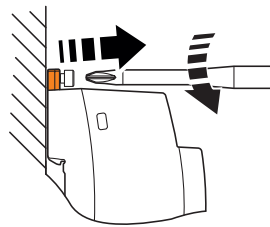

Figure 13 Loosening the screw fixing of the power supply

9 Device connection terminal blocks

The front-mounted AC input terminal blocks and DC output terminal blocks of the power supply feature Push-in connection technology. No tools are necessary for wiring the primary and secondary side connection terminal blocks.



For the necessary connection parameters for the connection terminal blocks, refer to the technical data section.

9.1 AC input terminal blocks

The power supply is designed such that it can be operated on single-phase AC supply systems or on two phase conductors of three-phase systems. Here, the star supply system supports various supply system configurations, for example TT, TN, and IT systems.

The power supply is connected on the primary side via the Input AC connection terminal blocks (connection level 1.x, input).

The AC input terminal points and DC output terminal points of the Push-in connection terminal blocks are aligned at a 45° angle. This increases the number of non-isolated terminal points. No tools are necessary for wiring the primary and secondary side connection terminal blocks.



The power supply is approved for connection to TN, TT, and IT power grids with a maximum phase-to-phase voltage of 240 V AC.

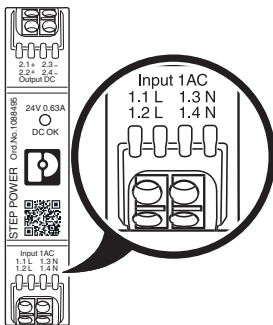

Figure 14 Position of the AC input terminal blocks

9.2 Primary side connection and fuse protection

The installation of the power supply must conform to the regulations of EN 61010. It must be possible to switch the power supply off using a suitable disconnection device outside of the power supply. The line protection on the primary side is suitable for this (see section: Technical data).

9.2.1 1AC supply network

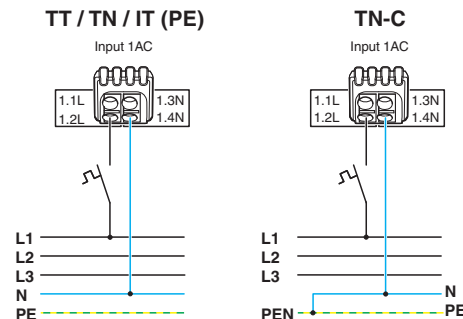

Figure 15 Schematic diagram, single-phase fuse protection

9.2.2 3AC supply network



DANGER: Hazardous voltage

When operating the power supply on a three-phase system, observe the maximum permissible phase-to-phase voltage (see section: Technical data).

The primary-side fuse protection in two-phase operation must be cover all poles.

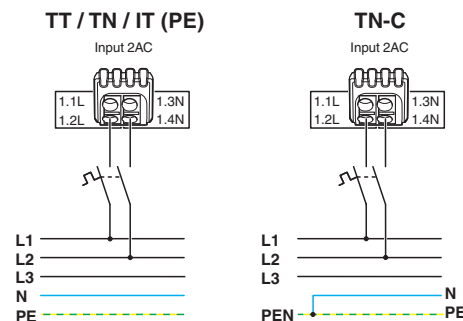

Figure 16 Schematic diagram, two-phase fuse protection

9.2.3 DC supply network



DANGER: Hazardous voltage

When operating the power supply on a DC voltage system, observe the maximum permissible input voltage (see section: Technical data).

The primary-side fuse protection in DC operation must cover all poles.



NOTE: Damage possible if an incorrect fuse is used

In DC operation, only use fuses that are approved for DC voltages.

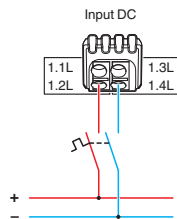

Figure 17 Schematic diagram, two-phase fuse protection

9.3 DC output terminal blocks

Connect the DC load to be supplied to the Output DC connection terminal blocks (connection level 2.x, output). By default, the power supply is preset to a nominal output voltage of 24 V DC. The level of the DC output voltage cannot be changed.

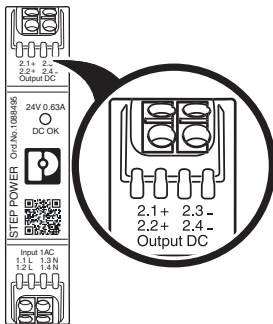

Figure 18 Position of DC output terminals

9.3.1 Wiring principle for DC output terminals

The power supply has two separate connection terminal blocks with positive and negative potentials for supplying DC loads. Connect the DC loads to be supplied to these connection terminal blocks.

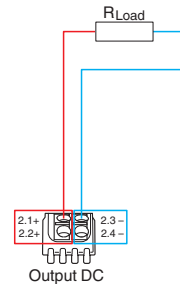

Figure 19 Wiring principle for DC output terminal blocks

9.3.2 Protection of the secondary side

The power supply is electronically short-circuit-proof and no-load-proof. In the event of an error, the output voltage is limited.



If sufficiently long connecting cables are used, fuse protection does not have to be provided for each individual load.

10 Function elements

The functional elements of the power supply are located on the front of the housing of the power supply and are categorized as follows:

- Display element

10.1 Display element – DC OK LED

A DC OK LED is available for preventive function monitoring of the power supply. Through various different signals, the DC OK LED provides information on the operating status of the power supply.

The possible DC OK statuses are to be found in the following table:

DC OK LED	Description
○	Primary-side AC supply is not available or too low. Power supply in Overload operation $U_{OUT} < 0.9 \times U_N$ ($U_N = 24 \text{ V DC}$)
●	Power supply in normal operation $U_{OUT} > 0.9 \times U_N$ ($U_N = 24 \text{ V DC}$)

○ = off, ● = on (green)



Figure 20 DC OK LED

11 Output characteristic curves

In normal operation, the power supply supplies the output power in accordance with the device nominal data. If the DC output current supplying the loads increases to an impermissibly high level due to a fault, the power supply disconnects the DC output. The power supply remains in operation, despite the functional disturbance.

The green DC OK LED is deactivated (see section: Function elements, display element – DC OK LED).

In HICCUP mode, the power supply attempts to return to the conditions present prior to the detected current increase cyclically. This procedure is repeated until the cause of the current increase due to overload or short circuit has been remedied. The power supply then automatically switches back to normal operation. The DC OK LED is reactivated.

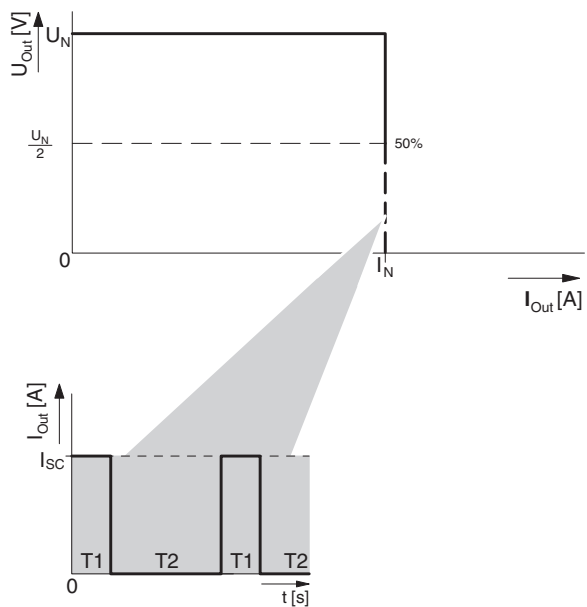

Figure 21 Schematic diagram, HICCUP mode in the event of overload

Marking	Value	Description
I_{SC}	approx. 2.8 A	Maximum output current (short-circuit current) in HICCUP mode
T1	2 ms	Pulse time (ON) in HICCUP mode
T2	300 ms	Pause time (OFF) in HICCUP mode

12 Connection versions

Depending on how you intend to use your power supply, there are different ways of connecting the DC output side.

A distinction is made between the following modes of use:

- Power increase
- Redundancy operation

12.1 Increasing power

Depending on the respective mode of use, the power is increased either via the series- or parallel connection of two power supplies.

12.1.1 Series operation

To increase the DC output power in dependence of the output voltage, connect two power supplies in series operation. Only use power supplies of the same type and performance class with identical configurations.

Depending on the common output-side ground reference point of the power supplies, the following DC output voltage potentials are possible:

- +48 V DC
- -48 V DC
- ± 24 V DC

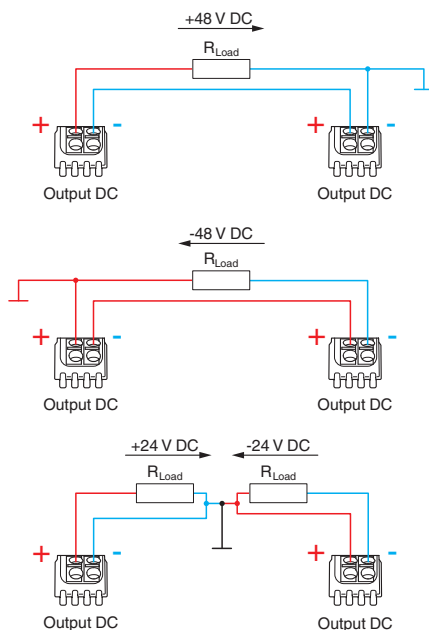

Figure 22 Schematic diagram, power increase in series operation

12.1.2 Parallel operation

When n power supply DC outputs are connected in parallel, the output current is increased to $n \times I_N$. Parallel connection for increased power is used when extending existing systems. If the individual power supply does not cover the current consumption of the most powerful load, parallel connection of power supplies is recommended.

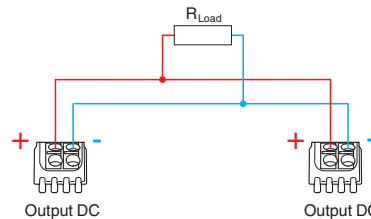

Figure 23 Schematic diagram, power increase in parallel operation

12.2 Redundant operation

Redundant circuits are suitable for the DC supply of systems and system parts which place particularly high demands on operational safety. If the DC load is to be supplied with 1+1 redundancy, two power supplies of the same type and performance class with identical configurations must be used.

In the event of an error, it must be ensured that one of the power supplies is able to provide the total required output power for the DC load to be supplied. The output power required for normal operation is thus provided by two power supplies connected in parallel on the output side. In normal operation, each of the two power supplies will be utilized by up to 50%.



A suitable selection of redundancy modules (active or passive) is to be found in the section: Ordering data, Accessories.

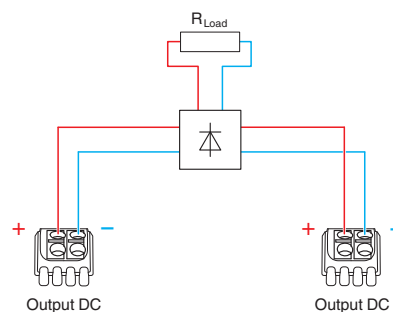

Figure 24 Schematic diagram, 1+1 redundancy with redundancy module (active or passive)

12.3 Fundamental prerequisites for parallel operation (power increase, redundancy operation)

In order to ensure correct parallel operation, observe the following rules:

DC output voltage: On each of the power supplies, set the DC voltage in idle mode such that the voltage values are identical. Take any voltage drops occurring due to long cable lengths into consideration.

Cable lengths: To ensure the symmetrical utilization of the power supplies, the connecting cables for supplying the DC load must be identical in length.

Cable cross sections: The connecting cables for supplying the DC load must be rated for the maximum occurring total current of all power supplies. This also applies for redundancy operation, whereby the individual power supply only supplies 50% of the DC load.

Ambient conditions: Select the installation location of the power supplies such that the prevailing ambient conditions are identical. This is of particular importance if the power supplies are installed in different mounting locations. Large temperature differences between the mounting locations have a negative effect on the operating points of the power supplies. This will result in the operating behavior of the power supplies no longer being identical.



If more than two power supplies are connected in parallel for the required power increase, fusing the DC outputs separately is recommended. Use appropriate miniature circuit breakers (MCBs) for this. As an alternative, the DC outputs can be decoupled from one another using redundancy modules (active or passive).

13 Derating

13.1 Ambient temperature

When mounted in the standard mounting position and operated within the permissible temperature range for nominal operation, the power supply provides full output power. If the power supply is operated beyond the temperature range for nominal values, note the reduced output power for the supply of DC loads.



NOTE: Damage due to thermal overload

If the power supply is operated in a different temperature range, only a reduced amount of power can be drawn. Otherwise, the power supply will be thermally loaded disproportionately and the device service life significantly reduced. This thermal load may even damage the power supply such that it is no longer operational.

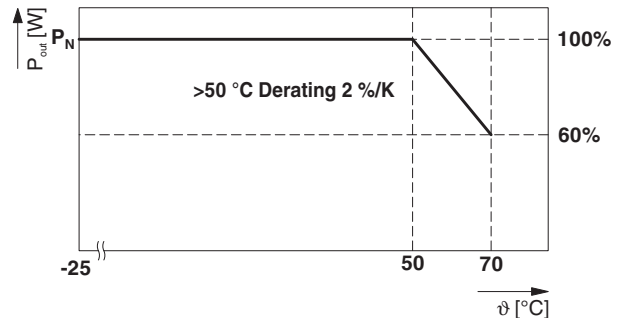

Figure 25 Output power depending on the ambient temperature

13.2 Installation height

The power supply can be operated at an installation height of up to 2000 m without any limitations. Different data applies for installation locations above 2000 m due to the differing air pressure and the reduced convection cooling associated with this.

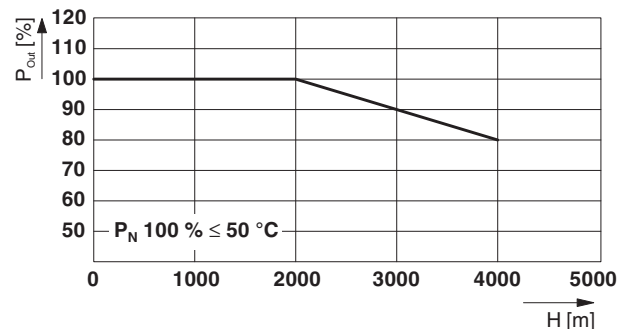

Figure 26 Output power depending on the installation height

13.3 Position-dependent derating

In order that you can use the nominal power of the power supply without limitation, the power supply should always be mounted in the standard mounting position. Sufficient device-side convection is always assured if the power supply is mounted in the standard mounting position and the necessary restricted areas are observed.



NOTE: Damage due to thermal overload

If the supply is mounted in a different mounting position, only a reduced amount of power can be drawn. Otherwise, the power supply will be thermally loaded disproportionately and the device service life significantly reduced.

13.3.1 Normal mounting position

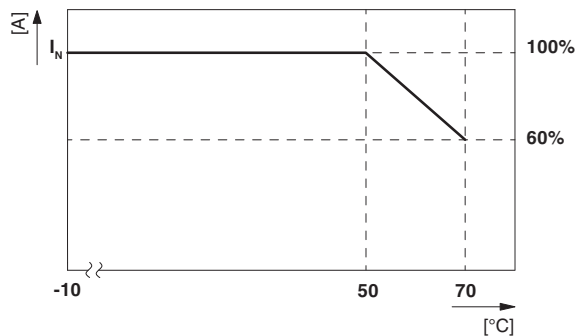
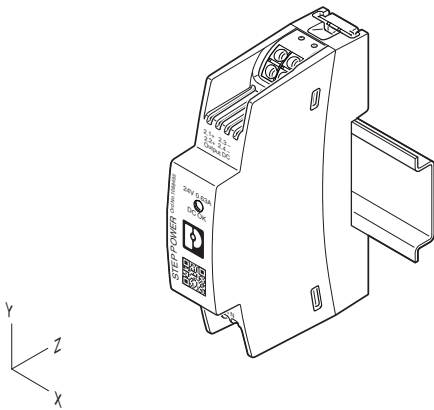

13.3.2 Rotated mounting position 90° Z-axis

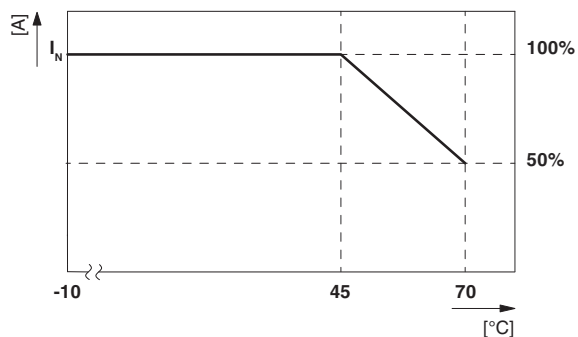
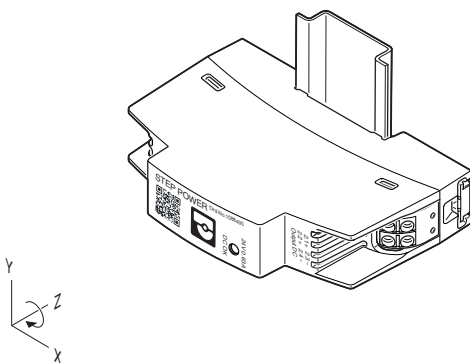

13.3.3 Rotated mounting position 180° Z-axis

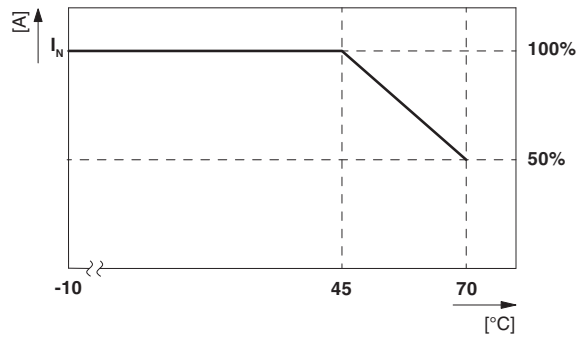
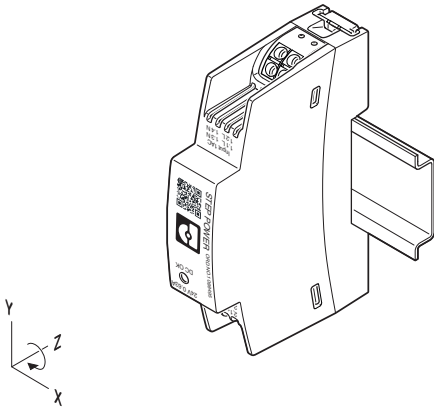

13.3.4 Rotated mounting position 270° Z-axis

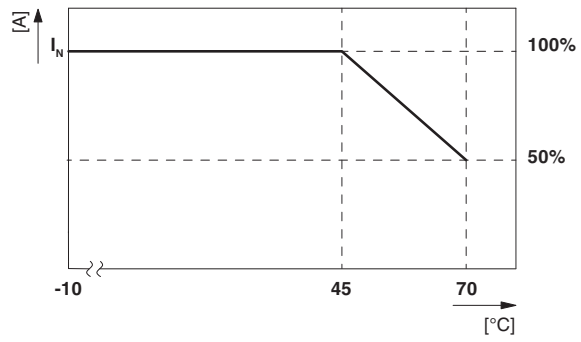
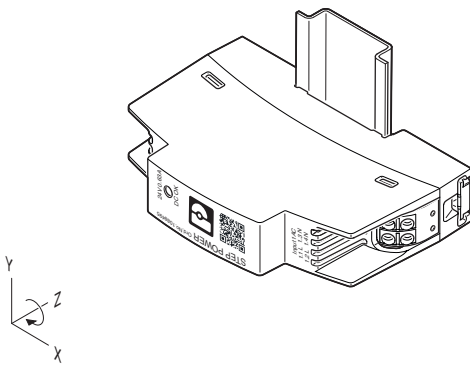

13.3.5 Rotated mounting position 90° X-axis

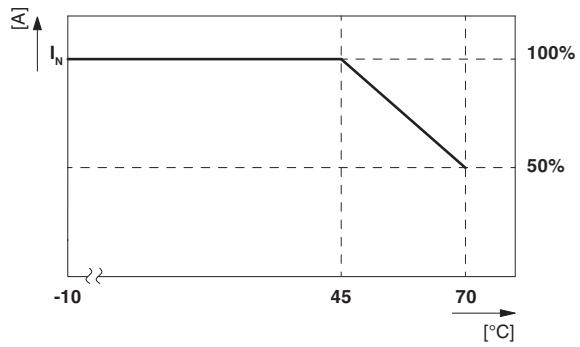
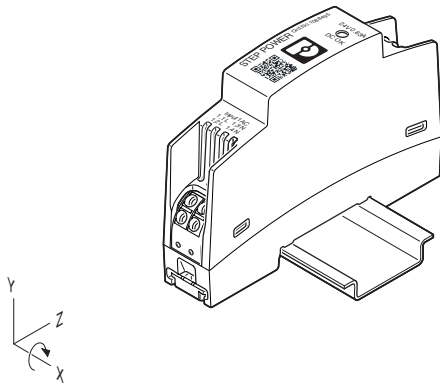

13.3.6 Rotated mounting position 270° X-axis

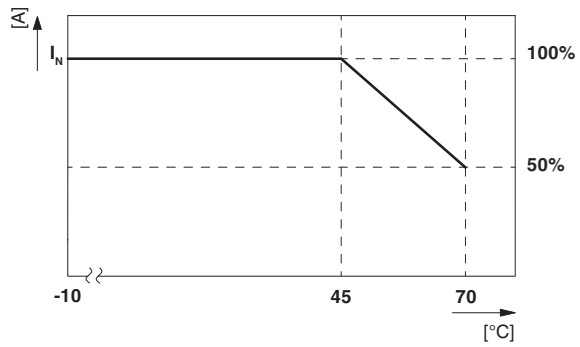
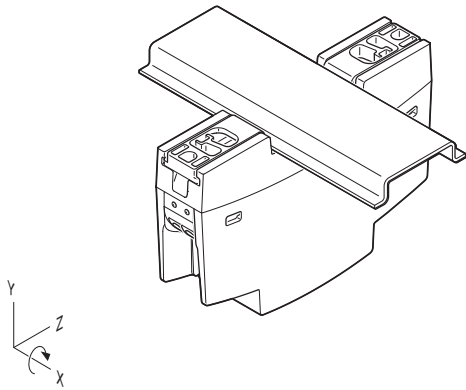

14 Application example

The individual performance classes of the STEP POWER power supplies have been designed such that the different housing widths are dimensioned in complete horizontal pitches (DIN 43880). Here, one horizontal pitch (1 HP) is 18 mm.

You can therefore install any possible combination in surface-mounted or flush mounted distributors (VDE 0603-1, DIN 43871).



The procedure for mounting the power supply in a surface-mounted or flush-mounted distributor is identical to that for DIN rail mounting (see section: Mounting the power supply).

14.1 Power supply in a surface-mounted or flush-mounted distributor

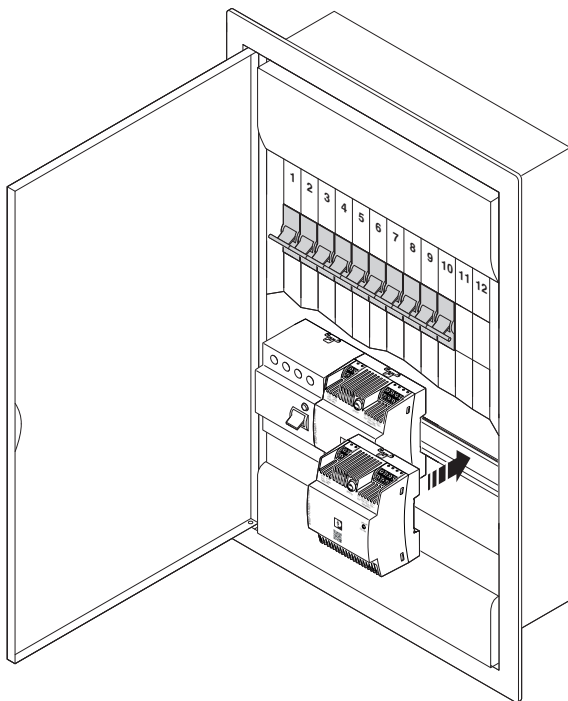

Figure 27 Schematic diagram, STEP POWER (4 HP) in a flush-mounted distributor (12 HP)

15 Disposal and recycling



Ensure the correct disposal of electronic components

Do not dispose of the power supply as household waste.

Observe the applicable national standards and regulations.



Ensure correct disposal or recycling

Dispose of or recycle packaging material that is no longer needed as household waste.

Observe the applicable national standards and regulations.

X-ON Electronics

Largest Supplier of Electrical and Electronic Components

Click to view similar products for [DIN Rail Power Supplies](#) category:

Click to view products by [Phoenix Contact](#) manufacturer:

Other Similar products are found below :

[DVP01PU-S](#) [DVDPNET-SL](#) [DVPDT01-S](#) [DVPPS01](#) [PS-6012](#) [PS9Z-5R1G](#) [PS-C24024](#) [DVP08ST11N](#) [DVPACAB530](#) [DVPCOPM-SL](#)
[DVPEN01-SL](#) [DVPPF01-S](#) [ADNB008-48-1PM-C](#) [ADNB017-24-1PM-C](#) [ADNB040-24-1PM-C](#) [ADNB034-12-1PM-C](#) [SS14011524](#) [PS-](#)
[UPS40](#) [PSD-A60W12](#) [96PS-A120WDIN](#) [PSD-A60W48](#) [PSD-A40W12](#) [PSD-A40W24](#) [PSD-A40W48](#) [PS-S4024](#) [NTPS-24-1.3](#) [ZI-20](#) [ZI-21](#)
[PST-96024](#) [S82YVSC4P](#) [PS-S4005](#) [PS-10024](#) [PS-S10024](#) [PS-C12024](#) [PSP-480S24](#) [PS-C48024](#) [PSC-2024](#) [PSC-4012](#) [PSC-4048](#) [PSC-9615](#)
[PSC-15124](#) [PSC-15148](#) [PSC-24148](#) [PSC-48148](#) [TRIO-PS-2G/1AC/12DC/5/C2LP](#) [PSA-6024](#) [PSS18/24/0.75](#) [PSS120/24/5](#) [PSD-A120W12](#)
[NDR-7548](#)