

Panel feed-through - QPD W 3PE2,5 M25 1,0 BK - 1582190

Please be informed that the data shown in this PDF Document is generated from our Online Catalog. Please find the complete data in the user's documentation. Our General Terms of Use for Downloads are valid (<http://phoenixcontact.com/download>)



Panel feed-through, QUICKON connection, number of positions: 3+PE, 1 mm² ... 2.5 mm², 690 V, 20 A, black, without QUICKON nut, cable diameter range: 6 mm ... 14 mm, assembly thread: M25, Single wires (welded-on), 2.5 mm², wires cut flat at the end, cable length: 1 m

Your advantages

- ✓ Innovative and time saving - QUICKON fast connection for time saving of up to 80 % for on-site connection
- ✓ Convenient: quick and easy assembly without special tools
- ✓ Robust throughout: housing with IP68/IP69K and IK07 protection for a wide range of applications
- ✓ Safer connection thanks to polarization against mismatching and touch-proof protection according to DIN EN 0105
- ✓ Efficient - by using panel feed-throughs, devices no longer need to be opened in order to connect cables

Key Commercial Data

Packing unit	1 pc
GTIN	 4 046356 316903
GTIN	4046356316903

Technical data

General

Type	QPD 4x2,5
Length of cable	1 m
Color	black
Locking type	Screw locking
Connection method	QUICKON connection IDC connection
Number of positions	4
Note number of positions	3+PE
Wrench size, union nut	22 mm
Tightening torque, union nut	5 Nm
Tightening torque, counter nut	5 Nm

Panel feed-through - QPD W 3PE2,5 M25 1,0 BK - 1582190

Technical data

General

Wrench size, counter nut	27 mm
Number of connections	10
Conductor cross section flexible min.	1 mm ²
Conductor cross section flexible max.	2.5 mm ²
Conductor cross section solid min.	1 mm ²
Conductor cross section solid max.	2.5 mm ²
Conductor cross section AWG min.	16
Conductor cross section AWG max.	14

Cabel

Structure of individual litz in acc. with VDE 0295 / smallest wire diameter	VDE 0295 class 1 to 6/min. 0.15 mm
Wire insulation material	PVC/PE/TPE/rubber
Wire diameter including insulation	2 mm ... 3.8 mm
External cable diameter	6 mm ... 14 mm (Order Quickon nuts or Quickon connectors separately)
Conductor cross section	2.5 mm ²
Position marking	1, 2, 3, PE

Ambient conditions

Degree of protection	IP66
	IP68 (2 m / 24 h)
	IP69K
Ambient temperature (operation)	-40 °C ... 100 °C
Ambient temperature (storage/transport)	-40 °C ... 100 °C
Temperature when conductor connected	-5 °C ... 50 °C

Electrical characteristics

Nominal current I_N	20 A
Nominal voltage U_N	690 V
Rated current	20 A
Rated voltage (III/3)	690 V
Rated voltage (III/2)	1000 V
Rated voltage (II/2)	1000 V
Rated surge voltage (III/3)	6 kV
Rated surge voltage (III/2)	8 kV
Rated surge voltage (II/2)	8 kV

Mechanical characteristics

QUICKON connectability	max. 10
Category of shock impact	IK07

Material data

Contact material	Cu
Contact surface material	silver-plated

Panel feed-through - QPD W 3PE2,5 M25 1,0 BK - 1582190

Technical data

Material data

Contact carrier material	PA
Insulating material	PA
Flammability rating according to UL 94	V0
Overvoltage category	III
Degree of pollution	3

Standards and Regulations

Category of shock impact	IK07
Flammability rating according to UL 94	V0

Environmental Product Compliance

China RoHS	Environmentally friendly use period: unlimited = EFUP-e
	No hazardous substances above threshold values

Drawings

Diagram

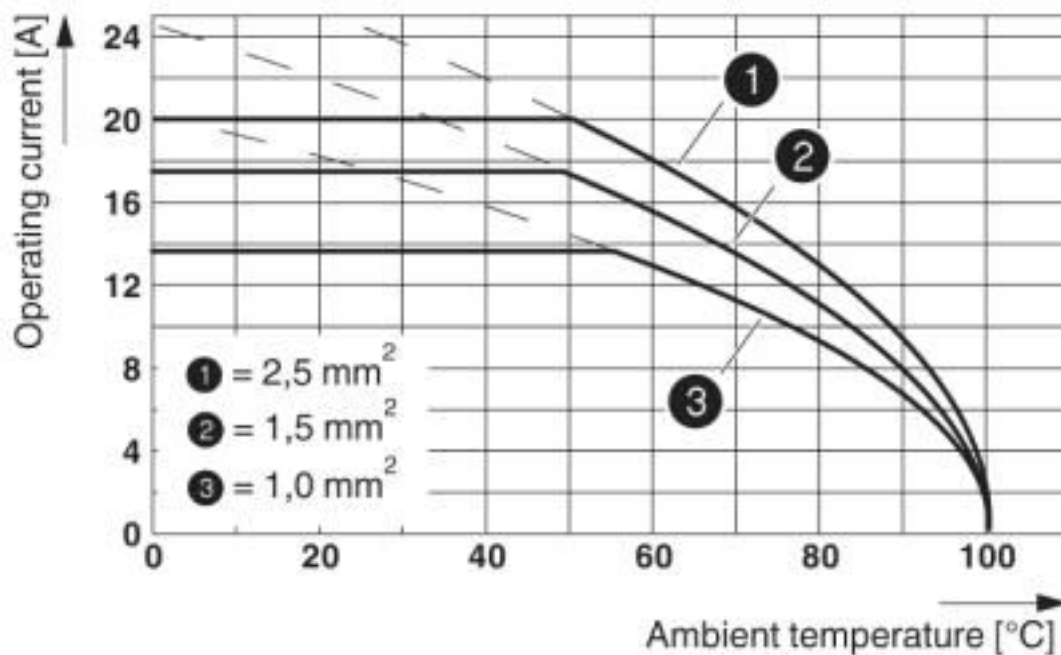

Panel feed-through - QPD W 3PE2,5 M25 1,0 BK - 1582190

Dimensional drawing

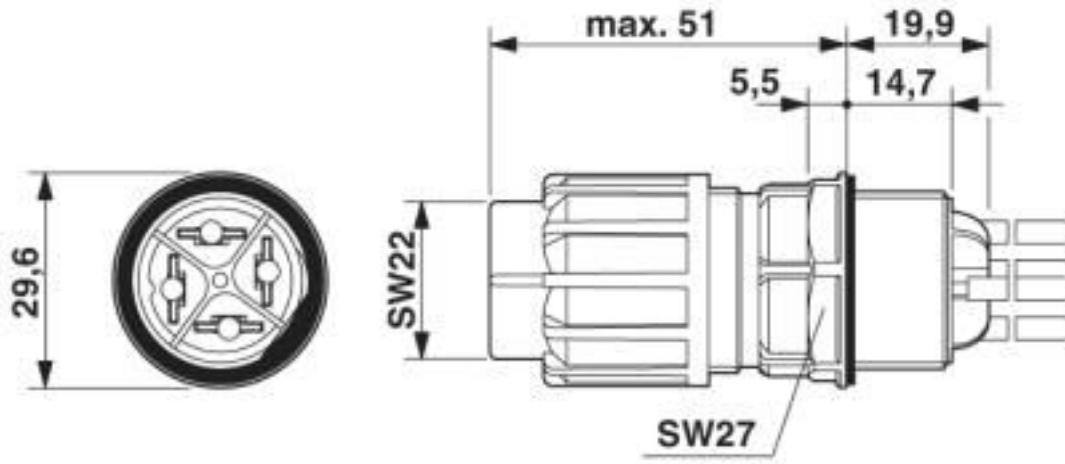

Panel feed-through - QPD W 3PE2,5 M25 1,0 BK - 1582190

Dimensional drawing

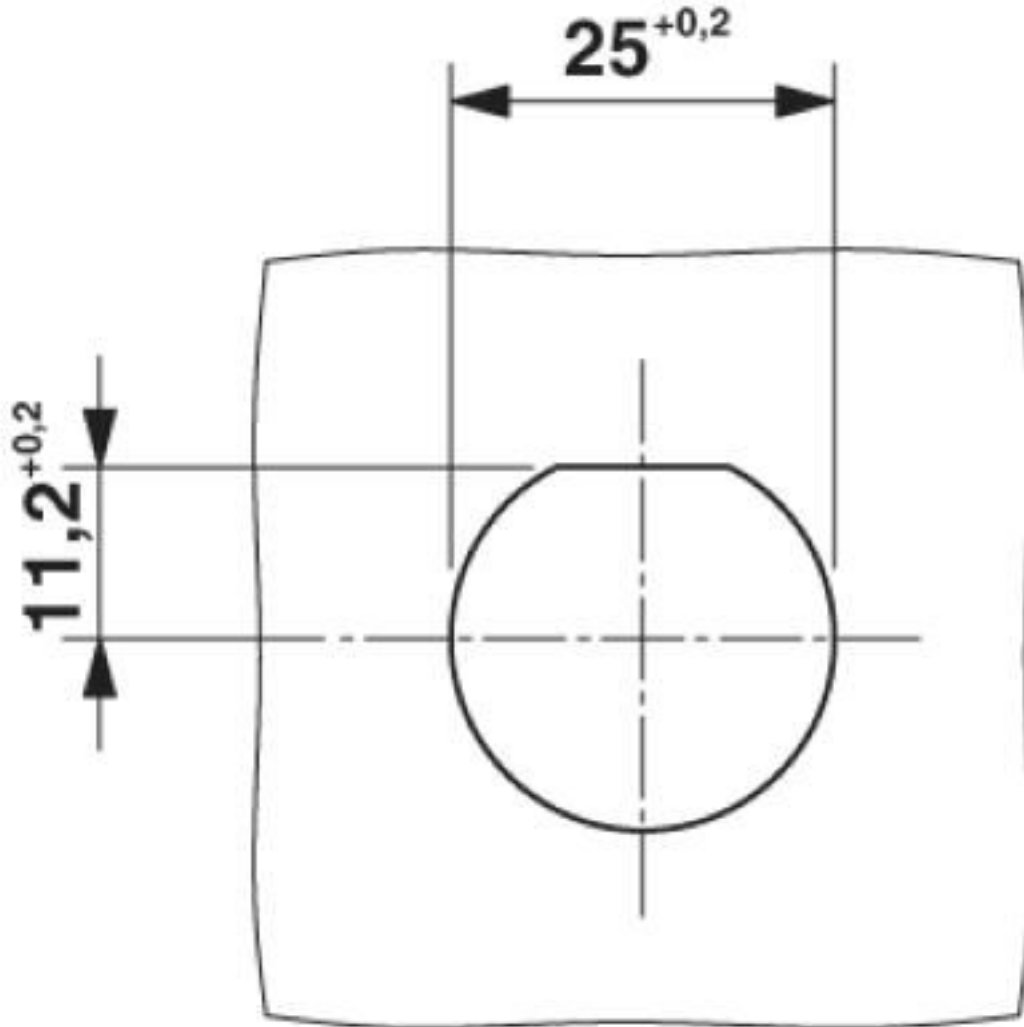

Panel cutout

Classifications

eCl@ss

eCl@ss 10.0.1	27440602
eCl@ss 4.0	27140800
eCl@ss 4.1	27140800
eCl@ss 5.0	27143400
eCl@ss 5.1	27143400
eCl@ss 6.0	27143400
eCl@ss 7.0	27440602
eCl@ss 8.0	27440602

Panel feed-through - QPD W 3PE2,5 M25 1,0 BK - 1582190

Classifications

eCl@ss

eCl@ss 9.0	27440602
------------	----------

ETIM

ETIM 2.0	EC001297
ETIM 3.0	EC000516
ETIM 4.0	EC000516
ETIM 5.0	EC002566
ETIM 6.0	EC002566
ETIM 7.0	EC002566

UNSPSC

UNSPSC 6.01	30211923
UNSPSC 7.0901	39121522
UNSPSC 11	39121522
UNSPSC 12.01	39121522
UNSPSC 13.2	39121522
UNSPSC 18.0	39121522
UNSPSC 19.0	39121522
UNSPSC 20.0	39121522
UNSPSC 21.0	39121522

Approvals

Approvals

Approvals

EAC / EAC / DNV GL / IECCEB Scheme / UL Listed / cUL Listed / VDE Zeichengenehmigung / UL Listed / cUL Listed

Ex Approvals

Approval details

EAC		RU C- DE.AI30.B.01102
-----	--	--------------------------

EAC		RU C- DE.BL08.B.00511
-----	--	--------------------------

Panel feed-through - QPD W 3PE2,5 M25 1,0 BK - 1582190

Approvals

DNV GL		https://approvalfinder.dnvgl.com/	TAE00003J5
--------	--	---	------------

IECEE CB Scheme		http://www.iecee.org/	DE1-58228
-----------------	--	---	-----------

UL Listed		http://database.ul.com/cgi-bin/XYV/template/LISEXT/1FRAME/index.htm	FILE E 221474
-----------	--	---	---------------

cUL Listed		http://database.ul.com/cgi-bin/XYV/template/LISEXT/1FRAME/index.htm	FILE E 221474
------------	--	---	---------------

VDE Zeichengenehmigung		http://www2.vde.com/de/Institut/Online-Service/VDE-gepruefteProdukte/Seiten/Online-Suche.aspx	40029149
Nominal voltage UN	690 V		
Nominal current IN	20 A		
mm ² /AWG/kcmil	1.5-2.5		

UL Listed		http://database.ul.com/cgi-bin/XYV/template/LISEXT/1FRAME/index.htm	FILE E 468743
Nominal voltage UN	600 V		
Nominal current IN	15 A		
mm ² /AWG/kcmil	14		

cUL Listed		http://database.ul.com/cgi-bin/XYV/template/LISEXT/1FRAME/index.htm	FILE E 468743
Nominal voltage UN	600 V		
Nominal current IN	15 A		
mm ² /AWG/kcmil	14		

Panel feed-through - QPD W 3PE2,5 M25 1,0 BK - 1582190

Accessories

Accessories

Coding element

Coding profile - CP-QPD - 1582459



Coding profile red, for pushing into the QUICKON dome and connector, can be positioned in 90° steps.

Device marking

Plastic label - EMLP (13X9)R - 0819453



Plastic label, Roll, white, unlabeled, can be labeled with: THERMOMARK ROLLMASTER 300/600, THERMOMARK X1.2, THERMOMARK ROLL X1, THERMOMARK ROLL 2.0, THERMOMARK ROLL, mounting type: adhesive, lettering field size: 13 x 9 mm, Number of individual labels: 500

Engraving material - GPE 13X 9 WH - 0806932



Engraving material, Sheet, white, unlabeled, can be labeled with: PLOTMARK, ENGRAVING UNIT, CMS-P1-PLOTTER, P1 ENGRAVING UNIT, mounting type: adhesive, lettering field size: 13 x 9 mm, Number of individual labels: 120

Installation pressure nut

Nut - QPD N 2,5 6-10 BK - 1582226



Nut, QUICKON connection, number of positions: 3+PE, 1 mm² ... 2.5 mm², 690 V, 20 A, black, cable diameter range: 6 mm ... 10 mm

Nut - QPD N 2,5 9-14 BK - 1582229



Nut, QUICKON connection, number of positions: 3+PE, 1 mm² ... 2.5 mm², 690 V, 20 A, black, cable diameter range: 9 mm ... 14 mm

Panel feed-through - QPD W 3PE2,5 M25 1,0 BK - 1582190

Accessories

Mounting material

Nut - Q-MU M25 - 1640715



Nut (plastic) to lock the contact carrier from the inside of the device

Protective cap

Protective cap - QPD QSK 2,5 FS - 1582488



Plastic protective cap, for QPD-QUICKON connectors, green, with holding band, IP68

Protective cap - QPD QSK 2,5 - 1582150



Protective cap made of transparent plastic for QPD QUICKON connection 4x 2.5 mm², IP50.

Seal

Seal - KV-DI-PG16-1XASI - 1582462



Seal for one AS-i line, 17.2 x 9 mm, from NBR, black, for IP65/67 degree of protection

Seal - KV-DI-PG16-2XASI - 1582464



Seal for two AS-i lines, 17.2 x 9 mm, from NBR, black, for IP65/67 degree of protection

Socket spanner

Panel feed-through - QPD W 3PE2,5 M25 1,0 BK - 1582190

Accessories

Socket wrench - QSS 22 - 1670206



Allen wrench, for loosening and fastening the QUICKON union nut, WAF 22 mm

Phoenix Contact 2020 © - all rights reserved
<http://www.phoenixcontact.com>

PHOENIX CONTACT GmbH & Co. KG
Flachsmarktstr. 8
32825 Blomberg
Germany
Tel. +49 5235 300
Fax +49 5235 3 41200
<http://www.phoenixcontact.com>

X-ON Electronics

Largest Supplier of Electrical and Electronic Components

Click to view similar products for [Phoenix Contact](#) manufacturer:

Other Similar products are found below :

[1203259](#) [1893300](#) [1212619](#) [1927221](#) [1936102](#) [1730573](#) [3240366](#) [3240367](#) [1014246](#) [1014236](#) [1014240](#) [1014290](#) [1014293](#) [1806193](#)
[1823655](#) [1912825](#) [1842254](#) [1768260](#) [1716373](#) [1648030](#) [1579051](#) [1014235](#) [1014239](#) [1014229](#) [1212378](#) [2800744](#) [3006564](#) [2800741](#)
[5146480](#) [1623633](#) [1507793](#) [3025587](#) [3069708](#) [1431461](#) [1586976](#) [0311647](#) [1460160](#) [1771338](#) [3048387](#) [2814605](#) [0309086](#) [1513716](#)
[3035684](#) [5451417](#) [0202219](#) [1647747](#) [1730667](#) [1709267](#) [5449018](#) [0311634](#)