

# Single contact - PV-PTSPL-W/1L - 1705625

Please be informed that the data shown in this PDF Document is generated from our Online Catalog. Please find the complete data in the user's documentation. Our General Terms of Use for Downloads are valid (<http://phoenixcontact.com/download>)



Photovoltaic connector, Single contact, type: Circular conductor connection, single-pos., Connection method: Push-in spring connection



## Key Commercial Data

Packing unit	250 pc
GTIN	 4 0 4 6 3 5 6 7 8 9 2 2 6
GTIN	4046356789226

## Technical data

### Dimensions

Length [ l ]	24 mm
Hole diameter	1.3 mm

### General

Rated surge voltage (III/3)	4 kV
Rated surge voltage (III/2)	4 kV
Rated surge voltage (II/2)	4 kV
Rated voltage (III/3)	250 V
Rated voltage (III/2)	400 V
Rated voltage (II/2)	630 V
Connection in acc. with standard	EN-VDE
Nominal current $I_N$	41 A
Nominal cross section	6 mm <sup>2</sup>
Internal cylindrical gage	A3
Stripping length	15 mm

### Connection data

Conductor cross section flexible min.	2.5 mm <sup>2</sup>
Conductor cross section flexible max.	6 mm <sup>2</sup>

# Single contact - PV-PTSPL-W/1L - 1705625

## Technical data

### Connection data

Conductor cross section flexible, with ferrule without plastic sleeve min.	2.5 mm <sup>2</sup> min.
Conductor cross section flexible, with ferrule without plastic sleeve max.	6 mm <sup>2</sup> max.
Conductor cross section AWG min.	14
Conductor cross section AWG max.	10

### Standards and Regulations

Connection in acc. with standard	EN-VDE
Safety note	<ul style="list-style-type: none"> <li>• <b>WARNING:</b> Commission properly functioning products only. The products must be regularly inspected for damage. Decommission defective products immediately. Replace damaged products. Repairs are not possible.</li> </ul>
	<ul style="list-style-type: none"> <li>• <b>WARNING:</b> Only electrically qualified personnel may install and operate the product. They must observe the following safety notes. The qualified personnel must be familiar with the basics of electrical engineering. They must be able to recognize and prevent danger. The relevant symbol on the packaging indicates that only personnel familiar with electrical engineering are allowed to install and operate the product.</li> </ul>
	<p><b>WARNING:</b> The connectors may not be plugged in or disconnected under load. Ignoring the warning or improper use may damage persons and/or property.</p>
	<ul style="list-style-type: none"> <li>• The products are suitable for applications in plant, controller, and electrical device engineering.</li> </ul>
	<ul style="list-style-type: none"> <li>• Assembled products may not be manipulated or improperly opened.</li> </ul>
	<ul style="list-style-type: none"> <li>• Only use mating connectors that are specified in the technical data of the standards listed (e.g. the ones listed in the product accessories online at <a href="https://www.phoenixcontact.com/products">phoenixcontact.com/products</a>).</li> </ul>
	<ul style="list-style-type: none"> <li>• When using the product in direct connection with third-party manufacturers, the user is responsible.</li> </ul>
	<ul style="list-style-type: none"> <li>• For operating voltages &gt; 50 V AC, conductive connector housings must be grounded</li> </ul>
	<ul style="list-style-type: none"> <li>• Ensure that the protective or functional ground has been properly connected.</li> </ul>
	<ul style="list-style-type: none"> <li>• Observe the corresponding technical data. You will find information:                             <ul style="list-style-type: none"> <li>o On the product</li> <li>o On the packing label</li> <li>o In the supplied documentation</li> <li>o Online at <a href="https://www.phoenixcontact.com/products">phoenixcontact.com/products</a> under the product</li> </ul> </li> </ul>
	<ul style="list-style-type: none"> <li>• The installation notes/Design In documents online on the download page at <a href="https://www.phoenixcontact.com/products">phoenixcontact.com/products</a> must be observed for this product.</li> </ul>
	<ul style="list-style-type: none"> <li>• Use a protective cap to protect connectors that are not in use. The suitable accessories are available online in the accessory section of the product at <a href="https://www.phoenixcontact.com/products">phoenixcontact.com/products</a></li> </ul>
	<ul style="list-style-type: none"> <li>• The connector warms up in normal operation. Depending on the ambient conditions, the surface of the connector can continue to warm up. In this case, the user is responsible for posting warnings (e.g. DIN EN ISO 13732-1:2008-12).</li> </ul>
	<ul style="list-style-type: none"> <li>• Operate the connector only when it is fully plugged in and interlocked.</li> </ul>
	<ul style="list-style-type: none"> <li>• Ensure that when laying the cable, the tensile load on the connectors does not exceed the upper limit specified in the standards.</li> </ul>
	<ul style="list-style-type: none"> <li>• Observe the minimum bending radius of the cable. Lay the cable without twisting it.</li> </ul>

# Single contact - PV-PTSPL-W/1L - 1705625

## Technical data

### Environmental Product Compliance

China RoHS	Environmentally friendly use period: unlimited = EFUP-e
	No hazardous substances above threshold values

## Drawings

Dimensional drawing

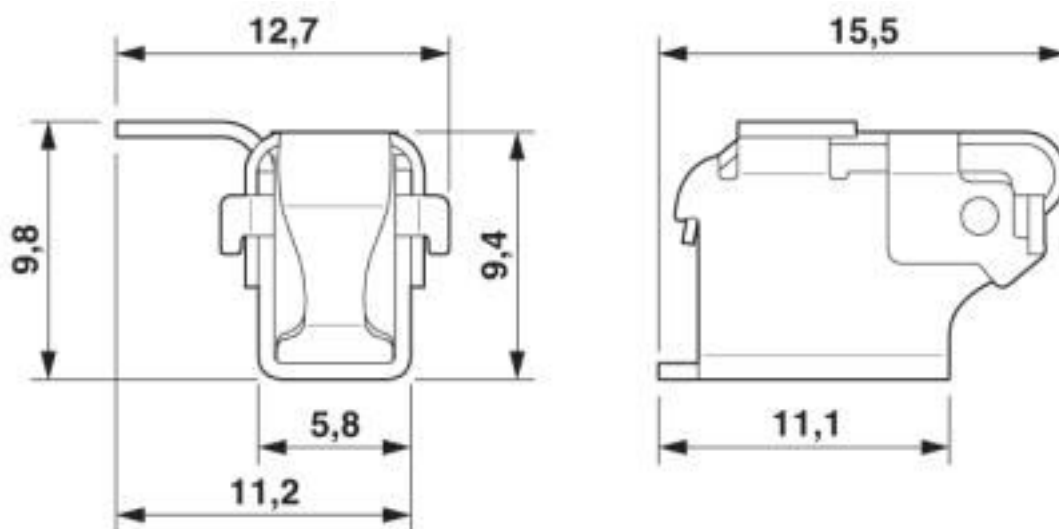

## Classifications

### eCl@ss

eCl@ss 10.0.1	27440204
eCl@ss 4.0	27260700
eCl@ss 4.1	27260700
eCl@ss 5.0	27260700
eCl@ss 5.1	27261200
eCl@ss 6.0	27261200
eCl@ss 7.0	27440204
eCl@ss 8.0	27440204
eCl@ss 9.0	27440204

### ETIM

ETIM 3.0	EC001121
ETIM 4.0	EC002638
ETIM 5.0	EC000796
ETIM 6.0	EC000796
ETIM 7.0	EC000796

# Single contact - PV-PTSPL-W/1L - 1705625

## Classifications

### UNSPSC

UNSPSC 6.01	30211810
UNSPSC 7.0901	39121409
UNSPSC 11	39121409
UNSPSC 12.01	39121409
UNSPSC 13.2	39121522
UNSPSC 18.0	39121522
UNSPSC 19.0	39121522
UNSPSC 20.0	39121522
UNSPSC 21.0	39121522

## Approvals

### Approvals

---

Approvals

EAC

---

Ex Approvals

---

### Approval details

EAC		B.01687
-----	--	---------

## Accessories

### Accessories

#### Crimping tool

Crimping pliers - CRIMPFOX 6 - 1212034



Crimping pliers, for ferrules without insulating collar according to DIN 46228 Part 1 and ferrules with insulating collar according to DIN 46228 Part 4, 0.25 mm<sup>2</sup> ... 6.0 mm<sup>2</sup>, lateral entry, trapezoidal crimp

### Screwdriver tools

## Single contact - PV-PTSPL-W/1L - 1705625

### Accessories

Screwdriver - SZF 1-0,6X3,5 - 1204517



Actuation tool, for ST terminal blocks, also suitable for use as a bladed screwdriver, size: 0.6 x 3.5 x 100 mm, 2-component grip, with non-slip grip

---

Phoenix Contact 2020 © - all rights reserved  
<http://www.phoenixcontact.com>

PHOENIX CONTACT GmbH & Co. KG  
Flachsmarktstr. 8  
32825 Blomberg  
Germany  
Tel. +49 5235 300  
Fax +49 5235 3 41200  
<http://www.phoenixcontact.com>

## X-ON Electronics

Largest Supplier of Electrical and Electronic Components

*Click to view similar products for [Fixed Terminal Blocks](#) category:*

*Click to view products by [Phoenix Contact](#) manufacturer:*

Other Similar products are found below :

[MBE-1512](#) [MBE-154](#) [MBE-156](#) [MBES-153](#) [MBES-156](#) [MH-2512](#) [MHE-132](#) [MHE-163](#) [MI-254 \(35\)](#) [MI-272](#) [880507](#) [MPT-275](#)  
[15602-04-08-21](#) [BA311TU](#) [BA411SU](#) [MV-152](#) [MV-252-D](#) [MV-253/NCNOC](#) [MV-254-D](#) [MV-255](#) [MV-462](#) [MV-493](#) [MVE-252](#) [MVE-253](#)  
[MVE-273](#) [MVEB-153](#) [1700096](#) [1705142](#) [1712417](#) [1713020](#) [1713088](#) [1745195](#) [1760594](#) [1776118-2](#) [1790852](#) [1-796689-8](#) [1-796692-6](#)  
[1800001](#) [1800114](#) [1995279](#) [20020314-C121B01LF](#) [CB2-12](#) [KP03215000J0G](#) [KP04215000J0G](#) [S451](#) [282802-2](#) [29.007](#) [29.116](#) [30.103](#)  
[30.106](#)