

## Front adapters - FLKM S115-454-7LA/S400 - 2314901

Please be informed that the data shown in this PDF Document is generated from our Online Catalog. Please find the complete data in the user's documentation. Our General Terms of Use for Downloads are valid (<http://phoenixcontact.com/download>)



The FLKM S115/S400 adapter links a SIMATIC® S5 plug directly with the basic SIMATIC® S7 400 card.  
Conversion: 6ES5 454-7LA12 to 6ES7 422 1BH11-0AA0

### Key Commercial Data

Packing unit	1 pc
GTIN	
GTIN	4046356155434

### Technical data

#### Note

Type of note	Notes on operation
Note	Due to the geometry, it is only possible to use every second slot. The LEDs of the S7-400 module are hidden by the S5-115 adapter.

#### Ambient conditions

Ambient temperature (operation)	-20 °C ... 50 °C
Ambient temperature (storage/transport)	-20 °C ... 70 °C
Degree of protection	IP00

#### General

Max. permissible operating voltage	60 V DC
Max. permissible current	4 A (per path)
	4 A (per connection, supply via separate power supply)
Mounting position	any

#### Connection data

Connection name	Field level
Connection method	SIEMENS S5-115 U pin strip

#### Supported controller

# Front adapters - FLKM S115-454-7LA/S400 - 2314901

## Technical data

### Supported controller

Controller	SIEMENS S5-115 U
- suitable I/O card	6ES5 454-7LA12

### Environmental Product Compliance

China RoHS	Environmentally Friendly Use Period = 50 years
	For details about hazardous substances go to tab "Downloads", Category "Manufacturer's declaration"

## Drawings

Circuit diagram

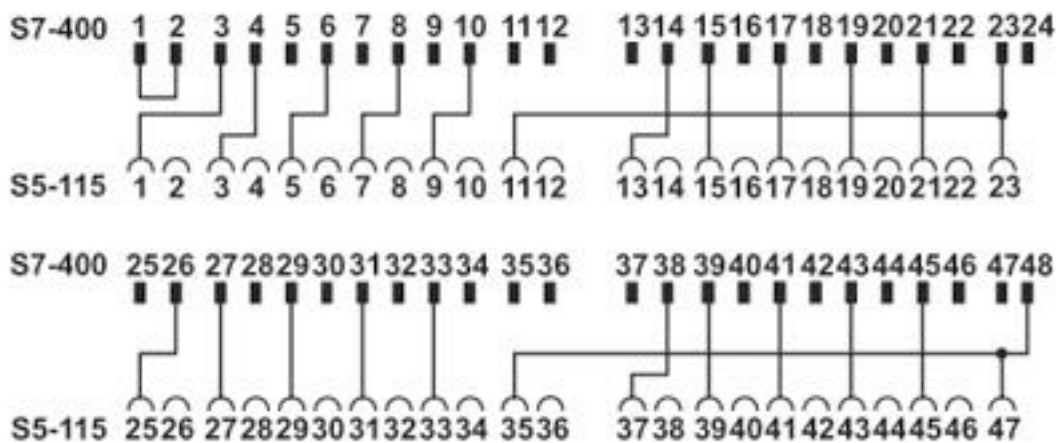

FLKM S115-454-7LA/S400 connection scheme

## Classifications

### eCl@ss

eCl@ss 10.0.1	27242292
eCl@ss 4.0	27250300
eCl@ss 4.1	27250300
eCl@ss 5.0	27250300
eCl@ss 5.1	27250300
eCl@ss 6.0	27249200
eCl@ss 7.0	27249290
eCl@ss 8.0	27249290
eCl@ss 9.0	27242292

### ETIM

ETIM 4.0	EC002584
ETIM 5.0	EC002584
ETIM 6.0	EC002584

# Front adapters - FLKM S115-454-7LA/S400 - 2314901

## Classifications

### ETIM

ETIM 7.0	EC002584
----------	----------

### UNSPSC

UNSPSC 6.01	30211824
UNSPSC 7.0901	39121421
UNSPSC 11	39121421
UNSPSC 12.01	39121421
UNSPSC 13.2	32151601
UNSPSC 18.0	32151601
UNSPSC 19.0	32151601
UNSPSC 20.0	32151601
UNSPSC 21.0	32151601

## Approvals

### Approvals

---

Approvals

EAC

---

Ex Approvals

---

### Approval details

EAC		RU C- DE.A*30.B.01742
-----	---	--------------------------

Phoenix Contact 2020 © - all rights reserved  
<http://www.phoenixcontact.com>

PHOENIX CONTACT GmbH & Co. KG  
Flachsmarktstr. 8  
32825 Blomberg  
Germany  
Tel. +49 5235 300  
Fax +49 5235 3 41200  
<http://www.phoenixcontact.com>

## X-ON Electronics

Largest Supplier of Electrical and Electronic Components

*Click to view similar products for [Terminal Block Tools & Accessories](#) category:*

*Click to view products by [Phoenix Contact](#) manufacturer:*

Other Similar products are found below :

[00171430102](#) [00171420102](#) [600HL](#) [600RJ-07](#) [600RJ-11](#) [600RJ-14](#) [600RJS-10](#) [600RJS-12](#) [600RJS-15](#) [600RJS-21](#) [601RJ-09](#) [602SP](#) [602Z](#)  
[604J](#) [CSTSPC1-2](#) [7B941-7](#) [88943-2100](#) [QC102](#) [1437403-6](#) [1437403-9](#) [1437403-8](#) [1453128-1](#) [147832-1](#) [EC0037-000](#) [MT2/H--](#) [MT6/H-N](#)  
[MT6/V-GRND](#) [MT8/H-51-60](#) [BC2-12](#) [BCC-1-8/10](#) [EP2.5/4UN/BG](#) [1707755](#) [1735590](#) [1755480](#) [1789281](#) [1840227](#) [1840230](#) [2-1437402-1](#)  
[JA2-03](#) [JB1-03/J](#) [JB2-04](#) [JB2-05](#) [JB2-07](#) [JB2-09/J](#) [PARALLELJUMPERLINK](#) [JS601](#) [2204082](#) [2302463](#) [2305949](#) [8PCV-BUSHING](#)