

Uninterruptible power supply - QUINT-UPS/ 1AC/ 1AC/500VA - 2320270

Please be informed that the data shown in this PDF Document is generated from our Online Catalog. Please find the complete data in the user's documentation. Our General Terms of Use for Downloads are valid (<http://phoenixcontact.com/download>)



Uninterruptible power supply with IQ technology 1AC/1AC/500 VA. For 120 V AC/230 V AC applications. Provides information regarding the charging state, remaining runtime, and service life of your rechargeable battery module at all times and thereby increases system availability.

Product Description

The UPS module for 120 V AC/230 V AC delivers a pure sine curve at the output. For 400 W/500 VA of power, only one energy storage is required, the power supply is already integrated.

Your advantages

- Optimum use of the buffer time and preventive monitoring of the energy storage
- Can be used worldwide
- Maximum efficiency
- Comprehensive signaling and parameterization
- Simplified startup



Key Commercial Data

Packing unit	1 pc
GTIN	 4 046356 560078
GTIN	4046356560078

Technical data

Dimensions

Width	125 mm
Height	130 mm
Depth	125 mm
Installation distance right/left	5 mm / 5 mm
Installation distance top/bottom	50 mm / 50 mm

Ambient conditions

Degree of protection	IP20
Ambient temperature (operation)	-25 °C ... 70 °C (> 50 °C Derating: 2.5 %/K)

Uninterruptible power supply - QUINT-UPS/ 1AC/ 1AC/500VA - 2320270

Technical data

Ambient conditions

Ambient temperature (start-up type tested)	-40 °C
Ambient temperature (storage/transport)	-40 °C ... 85 °C
Max. permissible relative humidity (operation)	≤ 95 % (25 °C, non-condensing)
Climatic class	3K3 (in acc. with EN 60721)

Input data

Nominal input voltage	240 V AC
	100 V AC
	120 V AC -20 % / +15 %
	230 V AC -20 % / +15 %
	100 V AC ... 240 V AC
Input voltage range	184 V AC ... 264 V AC
	96 V AC ... 138 V AC
	96 V AC ... 264 V AC
AC frequency range	45 Hz ... 65 Hz
Buffer period	1 h (38 AH)
Permissible backup fuse	B16 230 V AC
Power factor (cos phi)	0.8

Output data

Nominal output voltage	120 V AC
	230 V AC
Nominal output current (I _N)	4.3 A (120 V AC, -25°C ... 50°C)
	2.2 A (230 V AC, -25°C ... 40°C)
POWER BOOST (I _{Boost})	5.2 A (120 V AC, -25°C ... 40°C)
	2.7 A (230 V AC, -25°C ... 40°C)
Derating	> 50 °C ... 70 °C (2.5%/K)
Connection in parallel	no
Connection in series	No

General

IQ technology	Yes
Net weight	2.2 kg
Efficiency	> 98 % (Mains operation)
	> 98 % (120 V AC)
	> 86 % (Battery operation)
MTBF (IEC 61709, SN 29500)	> 240513 h (40 °C)
Degree of protection	IP20
Protection class	I
Housing material	Steel sheet, zinc-plated
Mounting position	horizontal DIN rail NS 35, EN 60715
Assembly instructions	alignable: P _N ≥ 50%, 5 mm horizontally, 15 mm next to active components, 50 mm vertically

Uninterruptible power supply - QUINT-UPS/ 1AC/ 1AC/500VA - 2320270

Technical data

General

	alignable: P _N <50%, 0 mm horizontally, 40 mm vertically top, 20 mm vertically bottom
--	--

Connection data, input

Connection method	Screw connection
Conductor cross section solid min.	1.5 mm ²
Conductor cross section solid max.	6 mm ²
Conductor cross section flexible min.	1.5 mm ²
Conductor cross section flexible max.	4 mm ²
Conductor cross section AWG min.	18
Conductor cross section AWG max.	10
Stripping length	8 mm
Screw thread	M4

Connection data, output

Connection method	Screw connection
Conductor cross section solid min.	1.5 mm ²
Conductor cross section solid max.	6 mm ²
Conductor cross section flexible min.	1.5 mm ²
Conductor cross section flexible max.	4 mm ²
Conductor cross section AWG min.	18
Conductor cross section AWG max.	10
Stripping length	8 mm
Screw thread	M4

Connection data for signaling

Connection method	Screw connection
Conductor cross section solid min.	0.2 mm ²
Conductor cross section solid max.	2.5 mm ²
Conductor cross section flexible min.	0.2 mm ²
Conductor cross section flexible max.	2.5 mm ²
Conductor cross section AWG min.	24
Conductor cross section AWG max.	10
Stripping length	8 mm
Screw thread	M4

Standards

Rail applications	EN 50121-4
Standard designation	Limitation of harmonic line currents
Standards/regulations	EN 61000-3-2 (Class A)
Standard designation	Uninterruptible power supply systems
Standards/regulations	EN 62040-1

EMC data

Uninterruptible power supply - QUINT-UPS/ 1AC/ 1AC/500VA - 2320270

Technical data

EMC data

Electromagnetic compatibility	Conformance with EMC Directive 2014/30/EU
Low Voltage Directive	Conformance with Low Voltage Directive 2014/35/EC
Electrostatic discharge	EN 61000-4-2
Contact discharge	8 kV (Test Level 4)
Discharge in air	15 kV (Test Level 4)
Electromagnetic HF field	EN 61000-4-3
Frequency range	80 MHz ... 3 GHz
Test field strength	10 V/m
Frequency range	1 GHz ... 3 GHz
Test field strength	10 V/m
Frequency range	2 GHz ... 3 GHz
Test field strength	3 V/m
Comments	Criterion A
Fast transients (burst)	EN 61000-4-4
Input	2 kV (Test Level 3 - asymmetrical)
Output	2 kV (Test Level 3 - asymmetrical)
Signal	2 kV (Test Level 4 - asymmetrical)
Comments	Criterion A
Surge voltage load (surge)	EN 61000-4-5
Input	1 kV (Test Level 2 - symmetrical)
	2 kV (Test Level 3 - asymmetrical)
Output	1 kV (Test Level 2 - symmetrical)
	2 kV (Test Level 3 - asymmetrical)
Comments	Criterion A
Conducted interference	EN 61000-4-6
I/O/S	asymmetrical
Frequency range	0.15 MHz ... 80 MHz
Voltage	10 V (Test Level 3)
Comments	Criterion A
Criterion A	Normal operating behavior within the specified limits.
Criterion B	Temporary impairment to operational behavior that is corrected by the device itself.

Environmental Product Compliance

REACH SVHC	Lead 7439-92-1
China RoHS	Environmentally Friendly Use Period = 50 years
	For details about hazardous substances go to tab "Downloads", Category "Manufacturer's declaration"

Drawings

Uninterruptible power supply - QUINT-UPS/ 1AC/ 1AC/500VA - 2320270

Block diagram

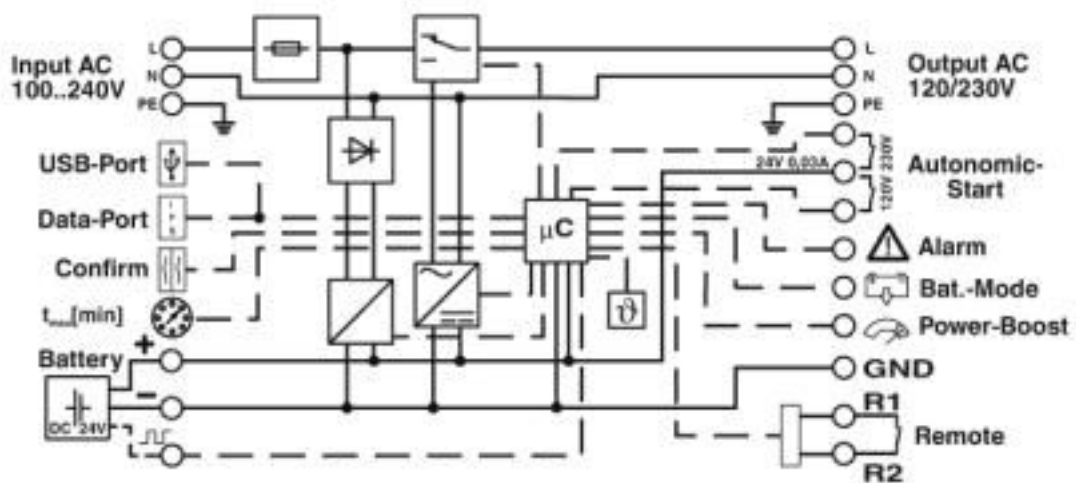

Classifications

eCl@ss

eCl@ss 10.0.1	27040705
eCl@ss 4.0	27040600
eCl@ss 4.1	27040600
eCl@ss 5.0	27040600
eCl@ss 5.1	27040600
eCl@ss 6.0	27040600
eCl@ss 7.0	27040602
eCl@ss 8.0	27040602
eCl@ss 9.0	27040705

ETIM

ETIM 3.0	EC001039
ETIM 4.0	EC000382
ETIM 5.0	EC000382
ETIM 6.0	EC000382
ETIM 7.0	EC000382

UNSPSC

UNSPSC 6.01	30211510
UNSPSC 7.0901	39121011
UNSPSC 11	39121011
UNSPSC 12.01	39121011
UNSPSC 13.2	39121011
UNSPSC 18.0	39121011
UNSPSC 19.0	39121011
UNSPSC 20.0	39121011

Uninterruptible power supply - QUINT-UPS/ 1AC/ 1AC/500VA - 2320270

Classifications

UNSPSC

UNSPSC 21.0	39121011
-------------	----------

Approvals

Approvals

Approvals

UL Recognized / cUL Recognized / EAC / EAC / IECEE CB Scheme / UL Recognized / IECEE CB Scheme / cUL Recognized / EAC / EAC

Ex Approvals

UL Recognized / cUL Recognized / UL Recognized / cUL Recognized

Approval details

UL Recognized		http://database.ul.com/cgi-bin/XYV/template/LISEXT/1FRAME/index.htm	FILE E 342453
---------------	--	---	---------------

cUL Recognized		http://database.ul.com/cgi-bin/XYV/template/LISEXT/1FRAME/index.htm	FILE E 342453
----------------	--	---	---------------

EAC			EAC-Zulassung
-----	--	--	---------------

EAC			EAC-Zulassung
-----	--	--	---------------

IECEE CB Scheme		http://www.iecee.org/	SI-7771
-----------------	--	---	---------

UL Recognized		http://database.ul.com/cgi-bin/XYV/template/LISEXT/1FRAME/index.htm	FILE E 342453
---------------	--	---	---------------

IECEE CB Scheme		http://www.iecee.org/	SI-7771
-----------------	--	---	---------

Uninterruptible power supply - QUINT-UPS/ 1AC/ 1AC/500VA - 2320270

Approvals

cUL Recognized		http://database.ul.com/cgi-bin/XYV/template/LISEXT/1FRAME/index.htm	FILE E 342453
----------------	--	---	---------------

EAC			RU*DE*08.B.01873/19
-----	--	--	---------------------

EAC			RU*DE*08.B.01873/19
-----	--	--	---------------------

Accessories

Accessories

Assembly adapter

Assembly adapters - UWA 130 - 2901664



2-piece universal wall adapter for securely mounting the device in the event of strong vibrations. The profiles that are screwed onto the side of the device are screwed directly onto the mounting surface. The universal wall adapter is attached on the left/right.

Assembly adapters - UWA 182/52 - 2938235



Universal wall adapter for securely mounting the device in the event of strong vibrations. The device is screwed directly onto the mounting surface. The universal wall adapter is attached on the top/bottom.

Battery unit

Energy storage - UPS-BAT/VRLA/24DC/3.4AH - 2320306



Energy storage device, lead AGM, VRLA technology, 24 V DC, 3.4 Ah, tool-free battery replacement, automatic detection, and communication with QUINT UPS-IQ

Uninterruptible power supply - QUINT-UPS/ 1AC/ 1AC/500VA - 2320270

Accessories

Energy storage - UPS-BAT/VRLA/24DC/7.2AH - 2320319



Energy storage device, lead AGM, VRLA technology, 24 V DC, 7.2 Ah, tool-free battery replacement, automatic detection, and communication with QUINT UPS-IQ

Energy storage - UPS-BAT/VRLA/24DC/12AH - 2320322



Energy storage device, lead AGM, VRLA technology, 24 V DC, 12 Ah, tool-free battery replacement, automatic detection, and communication with QUINT UPS-IQ

Energy storage - UPS-BAT/VRLA/24DC/38AH - 2320335



Energy storage device, lead AGM, VRLA technology, 24 V DC, 38 Ah, automatic detection, and communication with QUINT UPS-IQ

Energy storage - UPS-BAT/VRLA-WTR/24DC/13AH - 2320416



Energy storage device, lead AGM, VRLA technology, 24 V DC, 13 Ah, tool-free battery replacement, automatic detection, and communication with QUINT UPS-IQ

Energy storage - UPS-BAT/VRLA-WTR/24DC/26AH - 2320429



Energy storage device, lead AGM, VRLA technology, 24 V DC, 26 Ah, tool-free battery replacement, automatic detection, and communication with QUINT UPS-IQ

Uninterruptible power supply - QUINT-UPS/ 1AC/ 1AC/500VA - 2320270

Accessories

Energy storage - UPS-BAT/LI-ION/24DC/120WH - 2320351



Energy storage device, LI-ION technology, 24 V DC, 120 Wh, for ambient temperatures of -20°C ... 60°C, automatic detection and communication with QUINT UPS-IQ

Energy storage - UPS-CAP/24DC/20A/20KJ - 2320380



Maintenance-free energy storage based on double-layer capacitor, 24 V DC, 20 kJ, automatic detection and communication with QUINT UPS-IQ

Data cable preassembled

Data cable - IFS-MINI-DIN-DATACABLE - 2320487



Data cable for communication, e.g., between Phoenix Contact type ILC 1xx Inline controllers and Phoenix Contact devices with the 12-pos. IFS data port, such as QUINT UPS-IQ UPS or TRIO UPS

Data cable - IFS-RS232-DATACABLE - 2320490



Data cable for communication between devices with a D-SUB 9 RS-232 connection and Phoenix Contact devices with the 12-pos. IFS data port such as QUINT UPS-IQ or TRIO UPS.

Data cable - IFS-USB-DATACABLE - 2320500



Used for communicating between industrial PCs and Phoenix Contact devices with the 12-pos. IFS data port, such as QUINT UPS or TRIO UPS.

Fuse

Uninterruptible power supply - QUINT-UPS/ 1AC/ 1AC/500VA - 2320270

Accessories

Fuse - FUSE 10A/400V GRL - 2908358



Fuse, nominal current: 10 A, length: 31.8 mm, diameter: 6.35 mm

Memory block

Memory block - IFS-CONFSTICK-L - 2901103



Multi-functional memory block with handle for the INTERFACE system; for easy storage and back up of the configuration.

Memory block - IFS-CONFSTICK-L - 2901103



Multi-functional memory block with handle for the INTERFACE system; for easy storage and back up of the configuration.

Programming cable

USB cable - CABLE-USB/MINI-USB-3,0M - 2986135



USB connecting cable: USB plug type A to USB plug type Mini-B; length: 3 m

X-ON Electronics

Largest Supplier of Electrical and Electronic Components

Click to view similar products for [UPS - Uninterruptible Power Supplies](#) category:

Click to view products by [Phoenix Contact](#) manufacturer:

Other Similar products are found below :

[SMART-1400-RM](#) [UPS1500ITSIT](#) [UPS12438](#) [UPS12434](#) [UPS25512](#) [UPS1024746](#) [UPS23916EBM](#) [UPSITSNMP](#) [TRIO-UPS-2G/1AC/24DC/5](#) [TRIO-UPS-2G/1AC/24DC/10](#) [QUINT4-UPS/24DC/24DC/20/EI](#) [QUINT4-UPS/24DC/24DC/5/USB](#) [QUINT4-UPS/24DC/24DC/20/US](#) [SLNSPSPMBRK](#) [MINI-BAT/12DC/2.6AH](#) [TSPC 240-124UPS](#) [AKKUTEC2440](#) [DR-UPS40](#) [UPS003LSM](#)
[1081430](#) [1082548](#) [1094596](#) [2320212](#) [2320225](#) [2320238](#) [2320241](#) [2320254](#) [2320267](#) [2320270](#) [2320377](#) [2320380](#) [2320393](#) [2320461](#)
[2866213](#) [2866226](#) [2866239](#) [2866242](#) [2866349](#) [2866352](#) [2866365](#) [2866417](#) [2866569](#) [2866572](#) [2866598](#) [2866611](#) [2866666](#) [2868703](#)
[2905907](#) [2905908](#) [2905909](#)