

Energy storage - UPS-BAT/VRLA/24DC/12AH - 2320322

Please be informed that the data shown in this PDF Document is generated from our Online Catalog. Please find the complete data in the user's documentation. Our General Terms of Use for Downloads are valid (<http://phoenixcontact.com/download>)



Energy storage device, lead AGM, VRLA technology, 24 V DC, 12 Ah, tool-free battery replacement, automatic detection, and communication with QUINT UPS-IQ

Product Description

For continuous monitoring and intelligent management, there is constant communication with the QUINT UPS. Thanks to automatic detection of the energy storage, and tool-free switching during operation, quick installation is possible. The QUINT UPS with IQ technology energy storage leaves the warehouse fully charged.

Your advantages

- ✓ Maximum buffer times
- ✓ Lead AGM (Absorbent Glass Mat) technology



Key Commercial Data

Packing unit	1 pc
GTIN	 4 046356 554107
GTIN	4046356554107
Weight per Piece (excluding packing)	8,940.000 g
Custom tariff number	85072080
Country of origin	China

Technical data

Dimensions

Width	202 mm
Height	202 mm
Depth	110 mm

Ambient conditions

Energy storage - UPS-BAT/VRLA/24DC/12AH - 2320322

Technical data

Ambient conditions

Degree of protection	IP20
Ambient temperature (operation)	0 °C ... 40 °C
Ambient temperature (storage/transport)	0 °C ... 40 °C
Max. permissible relative humidity (operation)	≤ 95 %
Degree of pollution	2

Input data

Nominal input voltage	24 V DC
Buffer period	22.5 min. (20 A)
	9 min. (40 A)

Output data

Nominal output voltage	24 V DC
Output current I_{max}	50 A
Connection in parallel	5
Connection in series	No
Output fuse	2x 25 A

General

IQ technology	Yes
Disposal	Used batteries must not be thrown away with household waste, they should instead be disposed of in accordance with applicable national regulations. They can also be returned to Phoenix Contact or the manufacturer.
Net weight	8.9 kg
Memory medium	Lead rechargeable battery module
Degree of protection	IP20
Protection class	III
Mounting position	horizontal DIN rail NS 35, EN 60715

Standards

Standard - Electrical safety	EN 60950-1/VDE 0805 (SELV)
Standard – Electronic equipment for use in electrical power installations and their assembly into electrical power installations	EN 50178/VDE 0160 (PELV)

Conformance/approvals

UL approvals	UL/C-UL listed UL 508
	UL/C-UL Recognized UL 60950-1
	UL ANSI/ISA-12.12.01 Class I, Division 2, Groups A, B, C, D (Hazardous Location)
Shipbuilding approval	DNV GL (EMC A), ABS
VdS approval	G 100001

Energy storage - UPS-BAT/VRLA/24DC/12AH - 2320322

Technical data

Environmental Product Compliance

REACH SVHC	Lead 7439-92-1
China RoHS	Environmentally Friendly Use Period = 3
	For details about hazardous substances go to tab "Downloads", Category "Manufacturer's declaration"

Drawings

Block diagram

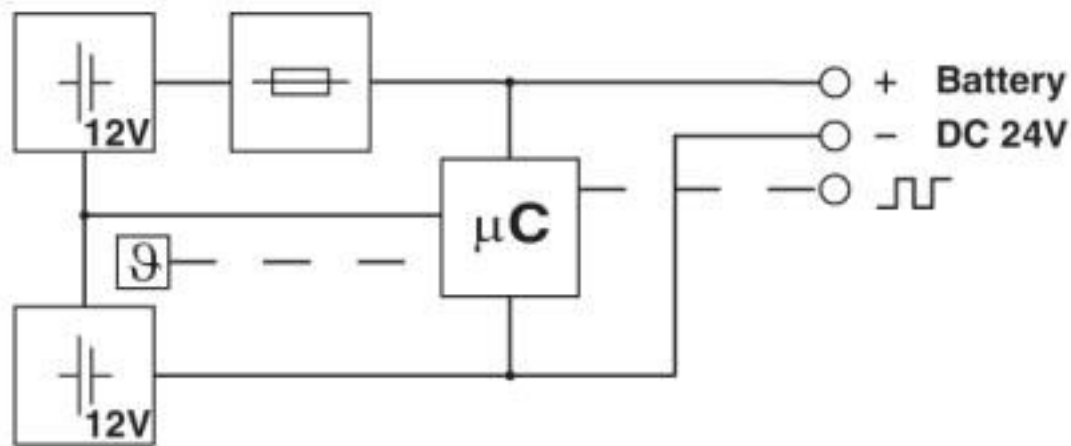

Classifications

eCl@ss

eCl@ss 10.0.1	27050403
eCl@ss 4.0	27040600
eCl@ss 4.1	27040600
eCl@ss 5.0	27040600
eCl@ss 5.1	27040600
eCl@ss 6.0	27040600
eCl@ss 7.0	27050403
eCl@ss 8.0	27050403
eCl@ss 9.0	27050403

ETIM

ETIM 2.0	EC000382
ETIM 3.0	EC000382
ETIM 4.0	EC000357

Energy storage - UPS-BAT/VRLA/24DC/12AH - 2320322

Classifications

ETIM

ETIM 5.0	EC000357
ETIM 6.0	EC000357
ETIM 7.0	EC000357

UNSPSC

UNSPSC 6.01	30211510
UNSPSC 7.0901	39121011
UNSPSC 11	39121011
UNSPSC 12.01	39121011
UNSPSC 13.2	26111715
UNSPSC 18.0	26111715
UNSPSC 19.0	26111715
UNSPSC 20.0	26111715
UNSPSC 21.0	26111715

Approvals

Approvals

Approvals

DNV GL / PRS / BV / LR / ABS / UL Listed / UL Recognized / cUL Recognized / cUL Listed / EAC / cULus Recognized / cULus Listed

Ex Approvals

UL Listed / cUL Listed / cULus Listed

Approval details

DNV GL		https://approvalfinder.dnvgl.com/	TAA0000265
Nominal voltage UN	500 V		
Nominal current IN	41 A		
mm ² /AWG/kcmil	6		

Energy storage - UPS-BAT/VRLA/24DC/12AH - 2320322

Approvals

PRS		http://www.prs.pl/	TE/2103/880590/16
BV		http://www.veristar.com/portal/veristarinfo/generalinfo/approved/approvedProducts/equipmentAndMaterials	41516/A0 BV
LR		http://www.lr.org/en	17/20032
ABS		http://www.eagle.org/eagleExternalPortalWEB/	15-GD1438179-PDA
UL Listed		http://database.ul.com/cgi-bin/XYV/template/LISEXT/1FRAME/index.htm	FILE E 123528
UL Recognized		http://database.ul.com/cgi-bin/XYV/template/LISEXT/1FRAME/index.htm	FILE E 211944
cUL Recognized		http://database.ul.com/cgi-bin/XYV/template/LISEXT/1FRAME/index.htm	FILE E 211944
cUL Listed		http://database.ul.com/cgi-bin/XYV/template/LISEXT/1FRAME/index.htm	FILE E 123528
EAC			DE.A*81.*10695
cULus Recognized			

Energy storage - UPS-BAT/VRLA/24DC/12AH - 2320322

Approvals

cULus Listed



Accessories

Accessories

Assembly adapter

Assembly adapters - QUINT-ADAPTER/4 - 2866857

Assembly adapter for QUINT-BAT/24DC... on 35mm rail



Battery unit

Uninterruptible power supply replacement battery - UPS-BAT-KIT-VRLA 2X12V/12AH - 2908235



Replacement battery for UPS-BAT/VRLA... energy storage

Fuse

Fuse - SI FORM C 25 A DIN 72581 - 0913757



Flat-type plug-in fuse, type C, color code: white, nominal current: 25 A

Energy storage - UPS-BAT/VRLA/24DC/12AH - 2320322

Accessories

Fuse - FUSE 25A/32V ATOF - 2908366



Fuse, nominal current: 25 A, length: 19.1 mm, width: 5 mm, height: 18.8 mm

X-ON Electronics

Largest Supplier of Electrical and Electronic Components

Click to view similar products for [Sealed Lead Acid Battery](#) category:

Click to view products by [Phoenix Contact](#) manufacturer:

Other Similar products are found below :

[0809-0012](#) [0819-0012](#) [0850-0004](#) [0859-0012](#) [0800-0004](#) [LC-R0612P](#) [LC-R061R3P](#) [PS-1250F1](#) [APCRBC123](#) [APCRBC124](#) [LCRA1212P](#)
[NP12-12](#) [NP12-6](#) [NP3.2-12](#) [LC-P0612P](#) [LC-R063R4P](#) [LC-R067R2P1](#) [LC-R122R2P](#) [LC-R0612P1](#) [LC-R127R2P1](#) [LC-X1220AP](#) [UP-](#)
[VW1245P1](#) [2320296](#) [RBC32](#) [RBC11A](#) [RBC36-SLT](#)