

# Power supply, with protective coating - QUINT-PS/3AC/24DC/20/CO - 2320924

Please be informed that the data shown in this PDF Document is generated from our Online Catalog. Please find the complete data in the user's documentation. Our General Terms of Use for Downloads are valid (<http://phoenixcontact.com/download>)



Primary-switched QUINT POWER power supply for DIN rail mounting with SFB (Selective Fuse Breaking) Technology, with protective coating, input: 3-phase, output: 24 V DC/20 A

## Product Description

QUINT POWER power supplies with maximum functionality

QUINT POWER circuit breakers magnetically and therefore quickly trip at six times the nominal current, for selective and therefore cost-effective system protection. In addition, the high system availability is ensured by preventive function monitoring which reports critical operating states before errors can occur.

Reliable starting of heavy loads takes place via the static power reserve POWER BOOST. Thanks to the adjustable voltage, all ranges between 18 V DC ... 29.5 V DC are covered.

## Your advantages

- ✓ For superior system availability
- ✓ Reliable starting of difficult loads with the static POWER BOOST power reserve with up to 1.5 times the nominal current permanently
- ✓ Fast tripping of standard circuit breakers with dynamic power reserve SFB (selective fuse breaking) technology with up to 6 times the nominal current for 12 ms
- ✓ Preventive function monitoring
- ✓ Optimum protection with dip coating for 100 % humidity



## Key Commercial Data

Packing unit	1 pc
GTIN	 4 046356 605601
GTIN	4046356605601

## Technical data

### Dimensions

Width	69 mm
Height	130 mm
Depth	125 mm
Width with alternative assembly	125 mm

# Power supply, with protective coating - QUINT-PS/3AC/24DC/20/CO - 2320924

## Technical data

### Dimensions

Height with alternative assembly	130 mm
Depth with alternative assembly	72 mm
Installation distance right/left	5 mm / 5 mm
Installation distance top/bottom	50 mm / 50 mm

### Ambient conditions

Degree of protection	IP20
Ambient temperature (operation)	-40 °C ... 70 °C (> 60 °C Derating: 2.5 %/K)
Ambient temperature (start-up type tested)	-40 °C
Ambient temperature (storage/transport)	-40 °C ... 85 °C
Max. permissible relative humidity (operation)	100 % (at 25 °C, non-condensing)
Climatic class	3K3 (in acc. with EN 60721)
Degree of pollution	2
Installation height	5000 m

### Input data

Nominal input voltage range	3x 400 V AC ... 500 V AC
Input voltage range	3x 320 V AC ... 575 V AC
	2x 360 V AC ... 575 V AC
	450 V DC ... 800 V DC
AC frequency range	45 Hz ... 65 Hz
Frequency range DC	0 Hz
Discharge current to PE	< 3.5 mA
Current consumption	3x 1.6 A (400 V AC)
	3x 1.3 A (500 V AC)
	0.9 A (600 V DC)
Nominal power consumption	783 VA
Inrush current	< 20 A (typical)
Mains buffering time	typ. 28 ms (400 V AC)
	typ. 43 ms (500 V AC)
Recommended breaker for input protection	6 A ... 16 A (AC: Characteristics B, C, D, K)
Type of protection	Transient surge protection
Protective circuit/component	Varistor, gas-filled surge arrester

### Output data

Nominal output voltage	24 V DC $\pm$ 1 %
Setting range of the output voltage ( $U_{Set}$ )	18 V DC ... 29.5 V DC (> 24 V DC, constant capacity restricted)
Nominal output current ( $I_N$ )	20 A (-25 °C ... 60 °C, $U_{OUT}$ = 24 V DC)
POWER BOOST ( $I_{Boost}$ )	26 A (-25 °C ... 40 °C permanent, $U_{OUT}$ = 24 V DC )
Selective Fuse Breaking ( $I_{SFB}$ )	120 A (12 ms)
Derating	60 °C ... 70 °C (2.5%/K)

# Power supply, with protective coating - QUINT-PS/3AC/24DC/20/CO - 2320924

## Technical data

### Output data

Connection in parallel	Yes, for redundancy and increased capacity
Connection in series	yes
Feedback voltage resistance	max. 32 V DC
Protection against overvoltage at the output (OVP)	< 32 V DC
Control deviation	< 1 % (change in load, static 10 % ... 90 %)
	< 3 % (change in load, dynamic 10 % ... 90 %)
	< 0.1 % (change in input voltage $\pm 10$ %)
Residual ripple	< 40 mV <sub>PP</sub> (with nominal values)
Output power	480 W
Typical response time	< 0.16 s
Peak switching voltages nominal load	< 40 mV <sub>PP</sub> (at nominal values, 20 MHz)
Maximum power dissipation in no-load condition	11 W
Power loss nominal load max.	40 W

### General

Net weight	1.5 kg
Efficiency	> 93 % (at 400 V AC and nominal values)
MTBF (IEC 61709, SN 29500)	> 900000 h (25 °C)
	> 534000 h (40 °C)
Insulation voltage input/output	4 kV AC (type test)
	2 kV AC (routine test)
Insulation voltage input / PE	3.5 kV AC (type test)
	2 kV AC (routine test)
Insulation voltage output / PE	500 V DC (routine test)
Degree of protection	IP20
Protection class	I
Housing material	Steel sheet, zinc-plated
Mounting position	horizontal DIN rail NS 35, EN 60715
Assembly instructions	alignable: $P_N \geq 50\%$ , 5 mm horizontally, 15 mm next to active components, 50 mm vertically alignable: $P_N < 50\%$ , 0 mm horizontally, 40 mm vertically top, 20 mm vertically bottom

### Connection data, input

Connection method	Screw connection
Conductor cross section solid min.	0.2 mm <sup>2</sup>
Conductor cross section solid max.	6 mm <sup>2</sup>
Conductor cross section flexible min.	0.2 mm <sup>2</sup>
Conductor cross section flexible max.	4 mm <sup>2</sup>
Conductor cross section AWG min.	18
Conductor cross section AWG max.	10

# Power supply, with protective coating - QUINT-PS/3AC/24DC/20/CO - 2320924

## Technical data

### Connection data, input

Stripping length	7 mm
Screw thread	M4

### Connection data, output

Connection method	Screw connection
Conductor cross section solid min.	0.2 mm <sup>2</sup>
Conductor cross section solid max.	6 mm <sup>2</sup>
Conductor cross section flexible min.	0.2 mm <sup>2</sup>
Conductor cross section flexible max.	4 mm <sup>2</sup>
Conductor cross section AWG min.	12
Conductor cross section AWG max.	10
Stripping length	7 mm
Screw thread	M4

### Connection data for signaling

Conductor cross section solid min.	0.2 mm <sup>2</sup>
Conductor cross section solid max.	6 mm <sup>2</sup>
Conductor cross section flexible min.	0.2 mm <sup>2</sup>
Conductor cross section flexible max.	4 mm <sup>2</sup>
Conductor cross section AWG min.	18
Conductor cross section AWG max.	10
Screw thread	M4

## Standards

EMC requirements for noise immunity	EN 61000-6-1
	EN 61000-6-2
EMC requirements for noise emission	EN 61000-6-3
	EN 61000-6-4
Standard - Electrical safety	IEC 60950-1/VDE 0805 (SELV)
Standard – Electronic equipment for use in electrical power installations and their assembly into electrical power installations	EN 50178/VDE 0160 (PELV)
Standard – Safety extra-low voltage	IEC 60950-1 (SELV) and EN 60204-1 (PELV)
Standard - Safe isolation	DIN VDE 0100-410
Standard – Protection against shock currents, basic requirements for protective separation in electrical equipment	EN 50178
Standard – Limitation of mains harmonic currents	EN 61000-3-2
Standard - Equipment safety	BG (design tested)
Mains variation/undervoltage	SEMI F47-0706 Compliance Certificate
Rail applications	EN 50121-4
	EN 50155

## Conformance/approvals

# Power supply, with protective coating - QUINT-PS/3AC/24DC/20/CO - 2320924

## Technical data

### Conformance/approvals

UL approvals	UL/C-UL listed UL 508
	UL/C-UL Recognized UL 60950-1 (3-wire + PE, star net)
	UL ANSI/ISA-12.12.01 Class I, Division 2, Groups A, B, C, D (Hazardous Location)
CSA	CAN/CSA-C22.2 No. 60950-1-07
	CSA-C22.2 No. 107.1-01
Shipbuilding approval	DNV GL (EMC B), ABS, LR, RINA, NK, BV

### EMC data

Electromagnetic compatibility	Conformance with EMC Directive 2014/30/EU
Low Voltage Directive	Conformance with Low Voltage Directive 2014/35/EC
Electrostatic discharge	EN 61000-4-2
Contact discharge	8 kV (Test Level 4)
Discharge in air	15 kV (Test Level 4)
Electromagnetic HF field	EN 61000-4-3
Frequency range	80 MHz ... 1 GHz
Test field strength	20 V/m (Test Level 3)
Frequency range	1 GHz ... 2 GHz
Test field strength	10 V/m (Test Level 3)
Frequency range	2 GHz ... 3 GHz
Test field strength	10 V/m (Test Level 3)
Comments	Criterion A
Fast transients (burst)	EN 61000-4-4
Input	4 kV (Test Level 4 - asymmetrical)
Output	2 kV (Test Level 3 - asymmetrical)
Signal	2 kV (Test Level 4 - asymmetrical)
Comments	Criterion B
Surge voltage load (surge)	EN 61000-4-5
Input	3 kV (Test Level 3 - symmetrical)
	6 kV (Test Level 4 - asymmetrical)
Output	1 kV (Test Level 2 - symmetrical)
	2 kV (Test Level 3 - asymmetrical)
Signal	1 kV (Test Level 2 - asymmetrical)
Comments	Criterion A
Conducted interference	EN 61000-4-6
I/O/S	asymmetrical
Frequency range	0.15 MHz ... 80 MHz
Voltage	10 V (Test Level 3)
Comments	Criterion A
Criterion A	Normal operating behavior within the specified limits.

# Power supply, with protective coating - QUINT-PS/3AC/24DC/20/CO - 2320924

## Technical data

### EMC data

Criterion B	Temporary impairment to operational behavior that is corrected by the device itself.
-------------	--

### Environmental Product Compliance

REACH SVHC	Lead 7439-92-1
China RoHS	Environmentally Friendly Use Period = 25;
	For details about hazardous substances go to tab "Downloads", Category "Manufacturer's declaration"

## Drawings

Block diagram

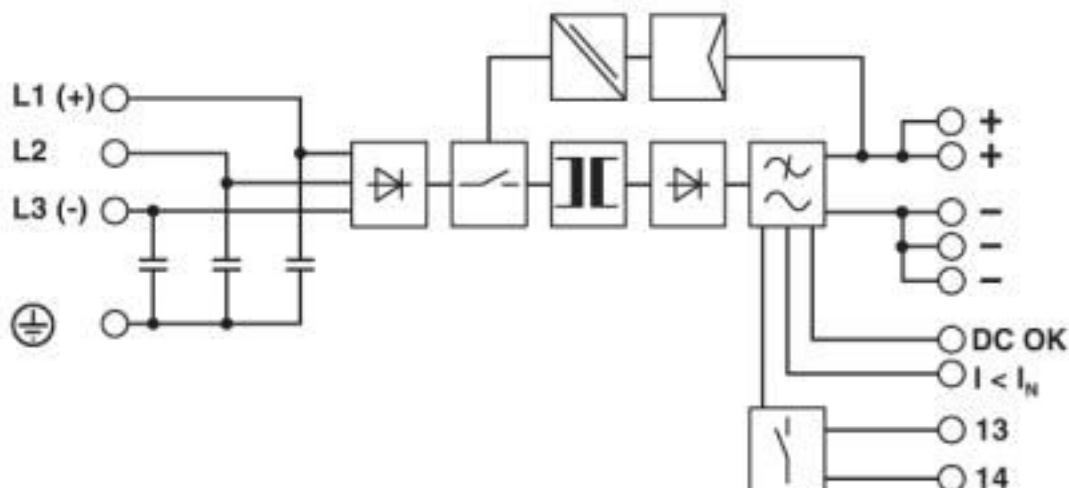

## Classifications

### eCl@ss

eCl@ss 10.0.1	27040701
eCl@ss 4.0	27040700
eCl@ss 4.1	27040700
eCl@ss 5.0	27049000
eCl@ss 5.1	27049000
eCl@ss 6.0	27049000
eCl@ss 7.0	27049002
eCl@ss 8.0	27049002
eCl@ss 9.0	27040701

### ETIM

ETIM 3.0	EC001039
----------	----------

# Power supply, with protective coating - QUINT-PS/3AC/24DC/20/CO - 2320924

## Classifications

### ETIM

ETIM 4.0	EC000599
ETIM 5.0	EC002540
ETIM 6.0	EC002540
ETIM 7.0	EC002540

### UNSPSC

UNSPSC 6.01	30211502
UNSPSC 7.0901	39121004
UNSPSC 11	39121004
UNSPSC 12.01	39121004
UNSPSC 13.2	39121004
UNSPSC 18.0	39121004
UNSPSC 19.0	39121004
UNSPSC 20.0	39121004
UNSPSC 21.0	39121004

## Approvals

### Approvals

#### Approvals

DNV GL / CSA / UL Listed / UL Recognized / cUL Recognized / IECCEB Scheme / EAC / Type approved / EAC / UL Recognized / IECCEB Scheme / CSA / UL Listed / cUL Recognized / EAC / DNV GL / EAC / Type approved

#### Ex Approvals

UL Listed / cUL Listed / UL Listed / cUL Listed

### Approval details

DNV GL		<a href="https://approvalfinder.dnvgl.com/">https://approvalfinder.dnvgl.com/</a>	TAE000014W
--------	--	---	------------

CSA		<a href="http://www.csagroup.org/services-industries/product-listing/">http://www.csagroup.org/services-industries/product-listing/</a>	1925529
-----	--	---	---------

UL Listed		<a href="http://database.ul.com/cgi-bin/XYV/template/LISEXT/1FRAME/index.htm">http://database.ul.com/cgi-bin/XYV/template/LISEXT/1FRAME/index.htm</a>	FILE E 123528
-----------	--	---	---------------

# Power supply, with protective coating - QUINT-PS/3AC/24DC/20/CO - 2320924

## Approvals

UL Recognized		<a href="http://database.ul.com/cgi-bin/XYV/template/LISEXT/1FRAME/index.htm">http://database.ul.com/cgi-bin/XYV/template/LISEXT/1FRAME/index.htm</a>	FILE E 211944
cUL Recognized		<a href="http://database.ul.com/cgi-bin/XYV/template/LISEXT/1FRAME/index.htm">http://database.ul.com/cgi-bin/XYV/template/LISEXT/1FRAME/index.htm</a>	FILE E 211944
IECEE CB Scheme		<a href="http://www.iecee.org/">http://www.iecee.org/</a>	SI-2794
EAC			EAC-Zulassung
Type approved			SI-SIQ BG 005/002
EAC			EAC-Zulassung
UL Recognized		<a href="http://database.ul.com/cgi-bin/XYV/template/LISEXT/1FRAME/index.htm">http://database.ul.com/cgi-bin/XYV/template/LISEXT/1FRAME/index.htm</a>	FILE E 211944
IECEE CB Scheme		<a href="http://www.iecee.org/">http://www.iecee.org/</a>	SI-2794
CSA		<a href="http://www.csagroup.org/services-industries/product-listing/">http://www.csagroup.org/services-industries/product-listing/</a>	1925529
UL Listed		<a href="http://database.ul.com/cgi-bin/XYV/template/LISEXT/1FRAME/index.htm">http://database.ul.com/cgi-bin/XYV/template/LISEXT/1FRAME/index.htm</a>	FILE E 123528



# Power supply, with protective coating - QUINT-PS/3AC/24DC/20/CO - 2320924

## Approvals

cUL Recognized		<a href="http://database.ul.com/cgi-bin/XYV/template/LISEXT/1FRAME/index.htm">http://database.ul.com/cgi-bin/XYV/template/LISEXT/1FRAME/index.htm</a>	FILE E 211944
----------------	--	---	---------------

EAC			RU*DE*08.B.01873/19
-----	--	--	---------------------

DNV GL		<a href="https://approvalfinder.dnvgl.com/">https://approvalfinder.dnvgl.com/</a>	TAE000014W
--------	--	---	------------

EAC			RU*DE*08.B.01873/19
-----	--	--	---------------------

Type approved			SI-SIQ BG 005/002
---------------	--	--	-------------------

## Accessories

### Accessories

#### Assembly adapter

##### Assembly adapters - UWA 182/52 - 2938235



Universal wall adapter for securely mounting the device in the event of strong vibrations. The device is screwed directly onto the mounting surface. The universal wall adapter is attached on the top/bottom.

##### Assembly adapters - QUINT-PS-ADAPTERS7/2 - 2938206



Assembly adapter for QUINT POWER 10A on S7-300 rail

## Device protection

## Power supply, with protective coating - QUINT-PS/3AC/24DC/20/CO - 2320924

### Accessories

Type 3 surge protection device - PLT-SEC-T3-3S-230-FM - 2905230



Plug-in device protection, according to type 3/class III, for 3-phase power supply networks with separate N and PE (5-conductor system: L1, L2, L3, N, PE), with integrated surge-proof fuse and remote indication contact.

---

Type 3 surge protection device - PLT-SEC-T3-24-FM-UT - 2907916



Type 3 surge protection, consisting of protective plug and base element, with integrated status indicator and remote signaling for single-phase power supply networks. Nominal voltage 24 V AC/DC.

---

### Fan

Fan - QUINT-PS/FAN/4 - 2320076



The fan for QUINT-PS/1AC and .../3AC can be mounted without the need for tools or other accessories. By using the fan, optimum cooling is ensured at high ambient temperatures or if the mounting position is rotated.

---

### Mounting rail adapter

DIN rail adapter - UTA 107 - 2853983

Universal DIN rail adapter, for screwing on switchgear



### Redundancy module

Diode - QUINT-DIODE/12-24DC/2X20/1X40 - 2320157



DIN rail diode module 12-24 V DC/2x20 A or 1x40 A. Uniform redundancy up to the consumer.

---

## Power supply, with protective coating - QUINT-PS/3AC/24DC/20/CO - 2320924

### Accessories

Redundancy module - TRIO-DIODE/12-24DC/2X10/1X20 - 2866514



Redundancy module with function monitoring, 12 ... 24 V DC, 2x 10 A, 1x 20 A

---

Redundancy module, with protective coating - QUINT-ORING/24DC/2X20/1X40 - 2320186



Active QUINT redundancy module for DIN rail mounting with ACB (Auto Current Balancing) Technology and monitoring functions, input: 24 V DC/2x 20 A, output: 24 V DC/1 x 40 A, including mounted UTA 107/30 universal DIN rail adapter

---

### Thermomagnetic device circuit breakers

Thermomagnetic device circuit breaker - CB TM1 1A SFB P - 2800836



Thermomagnetic device circuit breaker, 1-pos., tripping characteristic SFB, 1 PDT contact, plug for base element.

---

Thermomagnetic device circuit breaker - CB TM1 2A SFB P - 2800837



Thermomagnetic device circuit breaker, 1-pos., tripping characteristic SFB, 1 PDT contact, plug for base element.

---

Thermomagnetic device circuit breaker - CB TM1 3A SFB P - 2800838



Thermomagnetic device circuit breaker, 1-pos., tripping characteristic SFB, 1 PDT contact, plug for base element.

---

## Power supply, with protective coating - QUINT-PS/3AC/24DC/20/CO - 2320924

### Accessories

Thermomagnetic device circuit breaker - CB TM1 4A SFB P - 2800839



Thermomagnetic device circuit breaker, 1-pos., tripping characteristic SFB, 1 PDT contact, plug for base element.

---

Thermomagnetic device circuit breaker - CB TM1 5A SFB P - 2800840



Thermomagnetic device circuit breaker, 1-pos., tripping characteristic SFB, 1 PDT contact, plug for base element.

---

Thermomagnetic device circuit breaker - CB TM1 6A SFB P - 2800841



Thermomagnetic device circuit breaker, 1-pos., tripping characteristic SFB, 1 PDT contact, plug for base element.

---

Thermomagnetic device circuit breaker - CB TM1 8A SFB P - 2800842



Thermomagnetic device circuit breaker, 1-pos., tripping characteristic SFB, 1 PDT contact, plug for base element.

---

Thermomagnetic device circuit breaker - CB TM1 10A SFB P - 2800843



Thermomagnetic device circuit breaker, 1-pos., tripping characteristic SFB, 1 PDT contact, plug for base element.

---

## Power supply, with protective coating - QUINT-PS/3AC/24DC/20/ CO - 2320924

### Accessories

Thermomagnetic device circuit breaker - CB TM1 12A SFB P - 2800844



Thermomagnetic device circuit breaker, 1-pos., tripping characteristic SFB, 1 PDT contact, plug for base element.

---

Thermomagnetic device circuit breaker - CB TM1 16A SFB P - 2800845



Thermomagnetic device circuit breaker, 1-pos., tripping characteristic SFB, 1 PDT contact, plug for base element.

---

Phoenix Contact 2020 © - all rights reserved  
<http://www.phoenixcontact.com>

PHOENIX CONTACT GmbH & Co. KG  
Flachsmarktstr. 8  
32825 Blomberg  
Germany  
Tel. +49 5235 300  
Fax +49 5235 3 41200  
<http://www.phoenixcontact.com>

## X-ON Electronics

Largest Supplier of Electrical and Electronic Components

*Click to view similar products for [DIN Rail Power Supplies](#) category:*

*Click to view products by [Phoenix Contact](#) manufacturer:*

Other Similar products are found below :

[PS-S6024](#) [DVP01PU-S](#) [DVP06AD-S](#) [DVP06XA-S](#) [DVDPNET-SL](#) [DVPDT01-S](#) [DVPPS01](#) [PS-6012](#) [PS9Z-5R1G](#) [PS-C24024](#)  
[DVP08ST11N](#) [DVPACAB530](#) [DVPCOPM-SL](#) [DVPEN01-SL](#) [DVPPF01-S](#) [ADNB008-48-1PM-C](#) [ADNB017-24-1PM-C](#) [ADNB040-24-1PM-C](#) [ADNB034-12-1PM-C](#) [SS14011524](#) [PS-UPS40](#) [PSC-6024](#) [PSD-A60W12](#) [96PS-A120WDIN](#) [PSD-A60W48](#) [PSD-A40W12](#) [PSD-A40W24](#) [SMP21-L20-DC24V-5A](#) [PSD-A40W48](#) [S8T-DCBU-02](#) [PS-S4024](#) [NTPS-24-1.3](#) [PST-96024](#) [S82YVSC4P](#) [PS-S4005](#) [PS-10024](#)  
[PS-S10024](#) [PS-C12024](#) [PSP-480S24](#) [PS-C48024](#) [PSC-2024](#) [PSC-4012](#) [PSC-4048](#) [PSC-9615](#) [PSC-15124](#) [PSC-15148](#) [PSC-24148](#) [PSC-48148](#) [TRIO-PS-2G/1AC/12DC/5/C2LP](#) [QUINT4-PS/1AC/12DC/15](#)