

Patch panels - FL CAT5 TERMINAL BOX - 2744610

Please be informed that the data shown in this PDF Document is generated from our Online Catalog. Please find the complete data in the user's documentation. Our General Terms of Use for Downloads are valid (<http://phoenixcontact.com/download>)



Patch panel, one RJ45 jack to 4 screw connection terminal blocks (assignment 1, 2, 3, 6), CAT5e, 10/100 Mbps, DIN rail adapter, IP20, shield contacting on DIN rail

Product Description

Ethernet patch panels enable quick and easy connection between the field cabling and control cabinet cabling. The passive termination panels are a convenient alternative to the on-site assembly of RJ45 connectors.

Your advantages

- Safe shield connection to ground potential
- Mounting on a DIN rail
- 10/100 Mbps
- CAT5e
- Shipbuilding approval in accordance with DNV GL



Key Commercial Data

Packing unit	10 pc
GTIN	
GTIN	4017918819477

Technical data

Dimensions

Width	25 mm
Height	90 mm
Depth	52 mm

Ambient conditions

Ambient temperature (operation)	-25 °C ... 70 °C
Ambient temperature (storage/transport)	-25 °C ... 85 °C
Permissible humidity (operation)	25 % ... 95 % (non-condensing)
Degree of protection	IP20

Patch panels - FL CAT5 TERMINAL BOX - 2744610

Technical data

General

External cable diameter	6 mm ... 10 mm
Net weight	52.59 g
Housing material	PVC / PA
Color	green
MTBF	6702 Years (Telcordia standard, 25°C temperature, 21% operating cycle (5 days a week, 8 hours a day))
	2962 Years (Telcordia standard, 40°C temperature, 34.25% operating cycle (5 days a week, 12 hours a day))

Power supply

Typical current consumption	< 1 A
-----------------------------	-------

Interfaces

Interface 1	Ethernet interface, 10/100Base-T(X) in accordance with IEEE 802.3
No. of ports	1
Connection method	Screw connection
Transmission length	100 m (including patch cables)
Conductor cross section solid min.	0.14 mm ²
Conductor cross section solid max.	1.5 mm ²
Conductor cross section flexible min.	0.14 mm ²
Conductor cross section flexible max.	1 mm ²
Conductor cross section AWG min.	26
Conductor cross section AWG max.	16
Torque	0.22 Nm ... 0.25 Nm
Pin assignment	1:1
Serial transmission speed	10/100 Mbps
Interface 2	Ethernet interface, 10/100Base-T(X) in accordance with IEEE 802.3
No. of ports	1
Connection method	RJ45 CAT5e

Conformance/approvals

Designation	EAC
Identification	EAC
Designation	Shipbuilding
Identification	DNV GL
Temperature	B
Humidity	A
Vibration	A
EMC	B
Enclosure	Required protection according to the Rules shall be provided upon installation on board

Standards and Regulations

Type of test	Vibration resistance in acc. with EN 60068-2-6/IEC 60068-2-6
--------------	--

Patch panels - FL CAT5 TERMINAL BOX - 2744610

Technical data

Standards and Regulations

Test result	5g, 10...150 Hz, 2.5 h, in XYZ direction
Type of test	Shock in acc. with EN 60068-2-27/IEC 60068-2-27
Test result	25g, 11 ms period, half-sine shock pulse

Environmental Product Compliance

REACH SVHC	Lead 7439-92-1
China RoHS	Environmentally Friendly Use Period = 50 years
	For details about hazardous substances go to tab "Downloads", Category "Manufacturer's declaration"

Drawings

Dimensional drawing

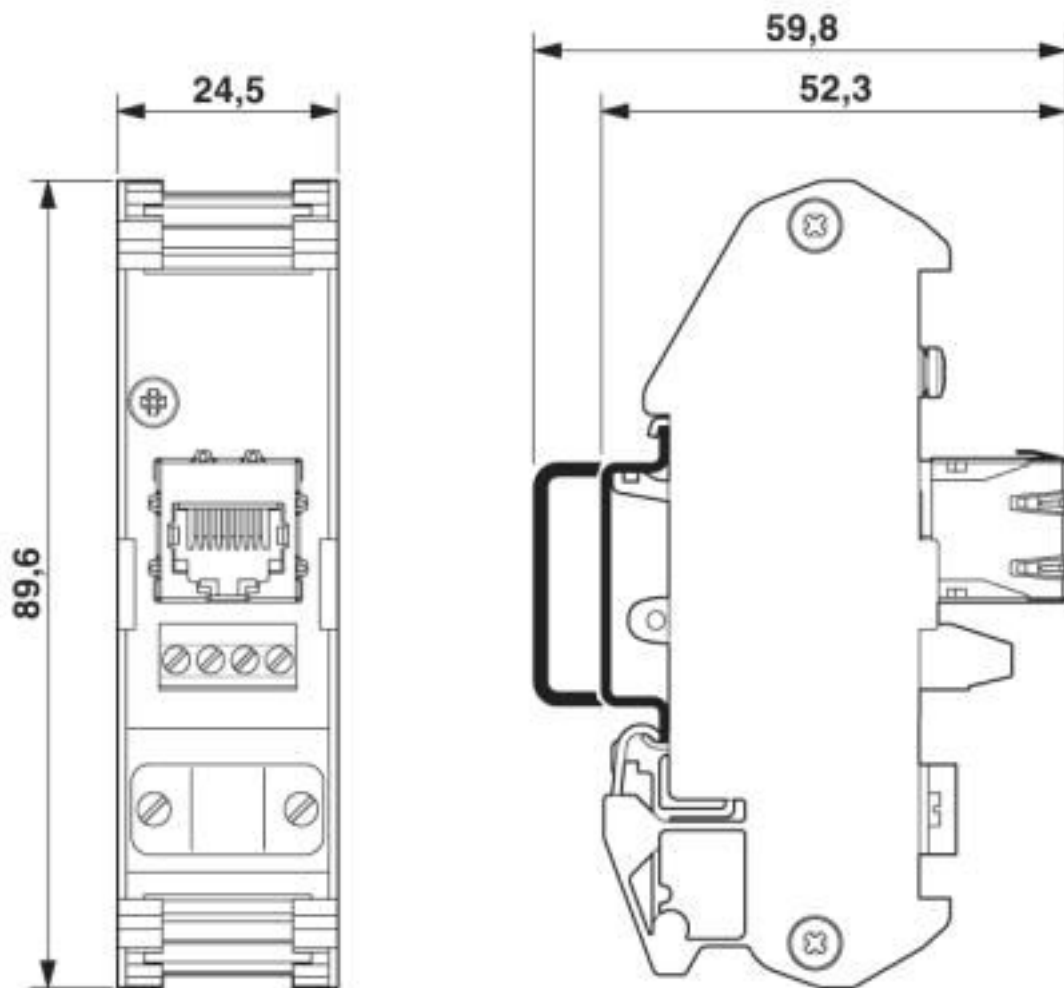

Patch panels - FL CAT5 TERMINAL BOX - 2744610

Circuit diagram

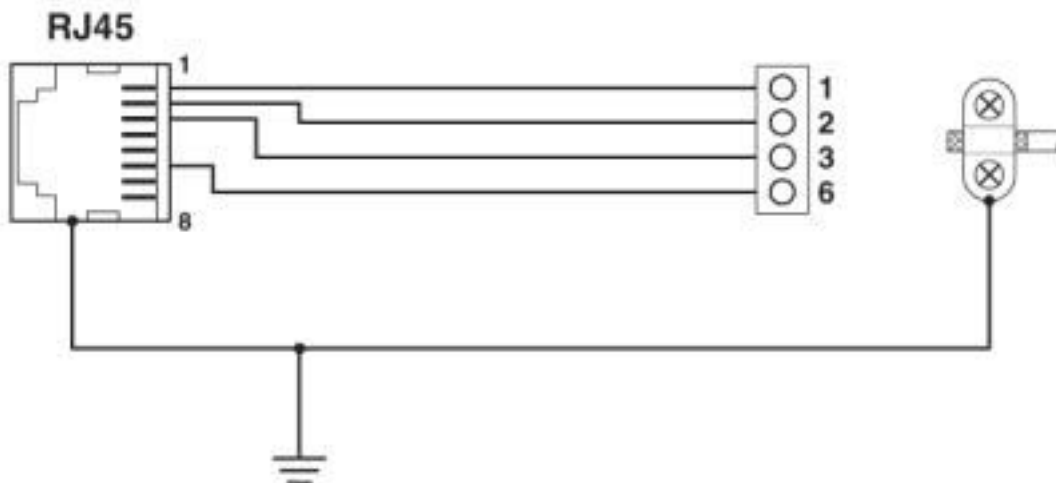

Classifications

eCl@ss

eCl@ss 10.0.1	19170112
eCl@ss 4.0	27230200
eCl@ss 4.1	27230200
eCl@ss 5.0	27230200
eCl@ss 5.1	27230200
eCl@ss 6.0	19170100
eCl@ss 7.0	19170112
eCl@ss 8.0	19170112
eCl@ss 9.0	19170112

ETIM

ETIM 2.0	EC001423
ETIM 3.0	EC001423
ETIM 4.0	EC001423
ETIM 5.0	EC002599
ETIM 6.0	EC002599
ETIM 7.0	EC002599

UNSPSC

UNSPSC 6.01	30211506
UNSPSC 7.0901	39121008
UNSPSC 11	39121008
UNSPSC 12.01	39121008
UNSPSC 13.2	26121604
UNSPSC 18.0	43223309
UNSPSC 19.0	43223309

Patch panels - FL CAT5 TERMINAL BOX - 2744610

Classifications

UNSPSC

UNSPSC 20.0	43223309
UNSPSC 21.0	43223309

Approvals

Approvals

Approvals

DNV GL / EAC

Ex Approvals

Approval details

DNV GL		https://approvalfinder.dnvgl.com/	TAA00001KR
--------	---	---	------------

EAC		EAC-Zulassung
-----	---	---------------

Accessories

Accessories

Data cable preassembled

Patch cable - NBC-R4AC/1,0-93B/R4AC - 1408968



PROFINET patch cable, shielded, star-quad, 22 AWG stranded (7-wire), green, straight RJ45 male connector/IP20 to straight RJ45 male connector/IP20, length: 1.0 m

Patch cable - NBC-R4AC/2,0-93B/R4AC - 1408969



PROFINET patch cable, shielded, star quad, 22 AWG stranded (7-wire), green, straight RJ45 plug/IP20, to straight RJ45 plug/IP20, length: 2 m

Patch panels - FL CAT5 TERMINAL BOX - 2744610

Accessories

Data plug

Assembly tool - FL CRIMPTOOL - 2744869



Crimping pliers, for assembling the RJ45 plugs FL PLUG RJ45..., for assembly on site

RJ45 connector - VS-PN-RJ45-5-Q/IP20 - 1658435



RJ45 connector, degree of protection: IP20, number of positions: 4, 100 Mbps, CAT5 (IEC 11801:2002), material: PA, connection method: IDC fast connection, cable outlet: straight, color: traffic grey A RAL 7042

Network isolator

Network isolator - FL ISOLATOR 100-RJ/SC - 2313928



Passive network isolator for electrical isolation in Ethernet networks. This protects Ethernet devices from potential differences of up to 4 kV. Can be used for transmission speeds of up to 100 Mbps. Connection using RJ45 and COMBICON plug-in screw terminal block.

Network isolator - FL ISOLATOR 100-RJ/RJ - 2313931



Passive network isolator for electrical isolation in Ethernet networks. This protects Ethernet devices from potential differences of up to 4 kV. Can be used for transmission speeds of up to 100 Mbps. Possible to connect two RJ45 plugs.

Network isolator - FL ISOLATOR 1000-RJ/RJ - 2313915



Passive network isolator for electrical isolation in Ethernet networks. This protects Ethernet devices from potential differences of up to 4 kV. Can be used for transmission speeds of up to 1 Gbps. Possible to connect two RJ45 plugs.

Patch cable

Patch panels - FL CAT5 TERMINAL BOX - 2744610

Accessories

Patch cable - FL CAT5 PATCH 0,3 - 2832250



Patch cable, CAT5, assembled, 0.3 m

Patch cable - FL CAT5 PATCH 0,5 - 2832263



Patch cable, CAT5, assembled, 0.5 m

Patch cable - FL CAT5 PATCH 1,0 - 2832276



Patch cable, CAT5, assembled, 1 m

Patch cable - FL CAT5 PATCH 1,5 - 2832221



Patch cable, CAT5, assembled, 1.5 m

Patch cable - FL CAT5 PATCH 2,0 - 2832289



Patch cable, CAT5, assembled, 2 m

Patch panels - FL CAT5 TERMINAL BOX - 2744610

Accessories

Patch cable - FL CAT5 PATCH 3,0 - 2832292



Patch cable, CAT5, assembled, 3 m

Screwdriver tools

Screwdriver - SZF 0-0,4X2,5 - 1204504



Actuation tool, for ST terminal blocks, also suitable for use as a bladed screwdriver, size: 0.4 x 2.5 x 75 mm, 2-component grip, with non-slip grip

Stripping tool - VS-CABLE-STRIP-VARIO - 1657407



Stripping tool, for the multi-level stripping of shielded cables

Phoenix Contact 2020 © - all rights reserved
<http://www.phoenixcontact.com>

PHOENIX CONTACT GmbH & Co. KG
Flachsmarktstr. 8
32825 Blomberg
Germany
Tel. +49 5235 300
Fax +49 5235 3 41200
<http://www.phoenixcontact.com>

X-ON Electronics

Largest Supplier of Electrical and Electronic Components

Click to view similar products for [Terminal Block Interface Modules](#) category:

Click to view products by [Phoenix Contact](#) manufacturer:

Other Similar products are found below :

[73-551-6002I](#) [GCN1MX25B](#) [DIN-50P-01](#) [DIN-68H-01](#) [DIN-96DI-01](#) [2291901](#) [2295185](#) [2907794](#) [2M10FCL](#) [FLKM-2I/O](#) [FLKM-4I/O](#)
[2281759](#) [2906251](#) [2907808](#) [5601749](#) [5541962](#) [1776613-1](#) [GCN1-004A](#) [ADAM-3920R-AE](#) [060-6827-06](#) [2311030](#) [2287708](#) [XW2C-20G6-](#)
[IO16](#) [GCN1-T](#) [MACX](#) [MCR-VAC](#) [5775235](#) [ADAM-3956-BE](#) [XW6T-COM2.5X20YL](#) [XW6T-COM1.5X8BL](#) [XW6T-COM1.5X16BL](#)
[XW6T-COM1.5X20YL](#) [XW6T-COM1.5X16YL](#) [XW6T-COM1.5X20RD](#) [XW6T-COM1.5X20BL](#) [XW6T-COM2.5X8BL](#) [1976610000](#) [UM](#)
[45-D50SUB/B/ZFKDS](#) [5541234](#) [410-261](#) [2906243](#) [2907706](#) [ADAM-3909-AE](#) [ADAM-3920-AE](#) [ADAM-3925-AE](#) [ADAM-3937-BE](#)
[ADAM-3950-AE](#) [ADAM-3951-BE](#) [ADAM-3968-AE](#) [ADAM-3968/50-AE](#) [2905026](#)