

Housing - UEG 30/2-FS/FS - 2790279

Please be informed that the data shown in this PDF Document is generated from our Online Catalog. Please find the complete data in the user's documentation. Our General Terms of Use for Downloads are valid (<http://phoenixcontact.com/download>)



Electronic housing, for two PCBs, fully equipped with 8 screw or tab connections per side

Your advantages

- ✔ Universal P1-UEG... PCBs are available for laboratory samples and small series
- ✔ Cost-effective series production, since the base element and the assembled PCB are soldered by machine
- ✔ Efficient assembly thanks to overlapping housing parts
- ✔ Up to 16 connections on two levels
- ✔ Can be snapped onto standard NS 35/7,5 and NS 35/15 DIN rails
- ✔ Installation of one or two PCBs in the housing



Key Commercial Data

Packing unit	10 pc
GTIN	 4 017918 072339
GTIN	4017918072339

Technical data

General

Housing type	Complete housing
Housing material	Polyamide (PA 6.6)
Color (RAL)	green

Ambient conditions

Ambient temperature (operation)	-40 °C ... 105 °C
---------------------------------	-------------------

Dimensions

Length	101.5 mm
Height	70 mm
Width	30 mm
Depth	101.5 mm

Housing - UEG 30/2-FS/FS - 2790279

Technical data

Technical data

Power dissipation without gap	4.8 W
Power dissipation with 20 mm gap	8 W
Number of positions	16

Connection data

Conductor cross section solid min.	0.2 mm ²
Conductor cross section solid max.	4 mm ²
Conductor cross section flexible min.	0.2 mm ²
Conductor cross section flexible max.	2.5 mm ²
Conductor cross section AWG min.	24
Conductor cross section AWG max.	12
Stripping length	8 mm

Standards and Regulations

Flammability rating according to UL 94	V2
--	----

Environmental Product Compliance

China RoHS	Environmentally friendly use period: unlimited = EFUP-e
	No hazardous substances above threshold values

Drawings

Explosion drawing

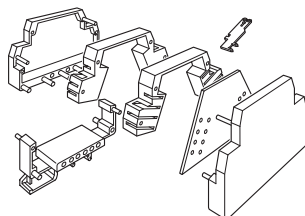

Dimensional drawing

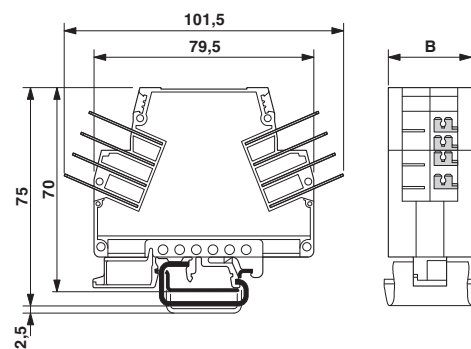

Housing - UEG 30/2-FS/FS - 2790279

Dimensional drawing

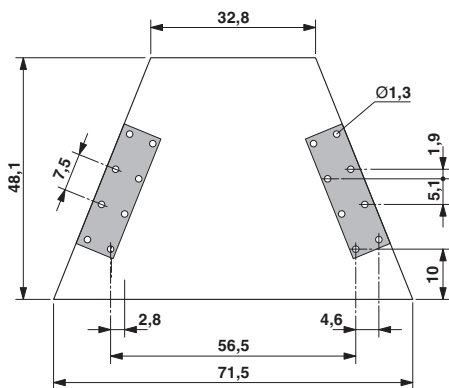

Schematic diagram

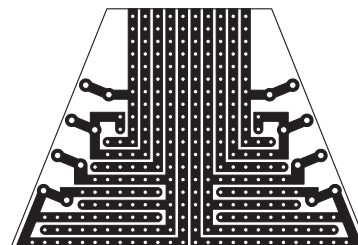

Approvals

Approvals

Approvals

UL Recognized / EAC

Ex Approvals

Approval details

UL Recognized		http://database.ul.com/cgi-bin/XYV/template/LISEXT/1FRAME/index.htm	FILE E 240868
---------------	--	---	---------------

EAC			B.01742
-----	--	--	---------

Phoenix Contact 2018 © - all rights reserved
<http://www.phoenixcontact.com>

PHOENIX CONTACT GmbH & Co. KG
Flachsmarktstr. 8
32825 Blomberg
Germany
Tel. +49 5235 300
Fax +49 5235 3 41200
<http://www.phoenixcontact.com>

X-ON Electronics

Largest Supplier of Electrical and Electronic Components

Click to view similar products for [Phoenix Contact](#) manufacturer:

Other Similar products are found below :

[1203259](#) [1893300](#) [1212619](#) [1927221](#) [1936102](#) [1730573](#) [3240366](#) [3240367](#) [1014246](#) [1014236](#) [1014240](#) [1014290](#) [1014293](#) [1806193](#)
[1823655](#) [1912825](#) [1842254](#) [1768260](#) [1716373](#) [1648030](#) [1579051](#) [1014235](#) [1014239](#) [1014229](#) [1212378](#) [2800744](#) [3006564](#) [2800741](#)
[5146480](#) [1623633](#) [1507793](#) [3025587](#) [3069708](#) [1431461](#) [1586976](#) [0311647](#) [1460160](#) [1771338](#) [3048387](#) [2814605](#) [0309086](#) [1513716](#)
[3035684](#) [5451417](#) [0202219](#) [1647747](#) [1730667](#) [1709267](#) [5449018](#) [0311634](#)