

## Basic terminal block - UM122-2FLK14/EX-MB/8/IN/S7 - 2865146

Please be informed that the data shown in this PDF Document is generated from our Online Catalog. Please find the complete data in the user's documentation. Our General Terms of Use for Downloads are valid (<http://phoenixcontact.com/download>)



Ex i motherboard to accept 8 x PI-Ex i repeater power supplies, input signal conditioners, etc. (PI-EX-...), FLK pin strips for connection to Siemens S7-300 analog in cards using system cables, assembly on NS 32, or NS 35/7.5.



### Key Commercial Data

Packing unit	1 pc
GTIN	 4 046356 046572
GTIN	4046356046572

### Technical data

#### Note

Utilization restriction	EMC: class A product, see manufacturer's declaration in the download area
-------------------------	---

#### Dimensions

Width	113.4 mm
Height	127.5 mm
Depth	92 mm

#### Ambient conditions

Ambient temperature (operation)	-20 °C ... 60 °C
Ambient temperature (storage/transport)	-40 °C ... 75 °C

#### General

Nom. voltage	20 V DC ... 35 V DC
Nominal current $I_N$	60 mA (max. current consumption)
Housing insulation material	Polyamide PA non-reinforced, polycarbonate PC, PVC
Flammability rating according to UL 94	V2
Color	green
Conformance	CE-compliant

# Basic terminal block - UM122-2FLK14/EX-MB/8/IN/S7 - 2865146

## Technical data

### General

ATEX	# II (1) GD [EEx ia] IIC
------	--------------------------

### Standards and Regulations

Flammability rating according to UL 94	V2
Conformance	CE-compliant
ATEX	# II (1) GD [EEx ia] IIC

### Environmental Product Compliance

REACH SVHC	Lead 7439-92-1
China RoHS	Environmentally Friendly Use Period = 50
	For details about hazardous substances go to tab "Downloads", Category "Manufacturer's declaration"

## Drawings

Dimensional drawing

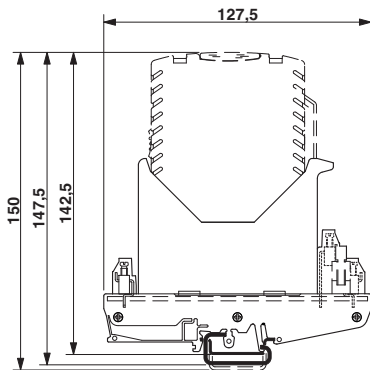

Dimensional drawing

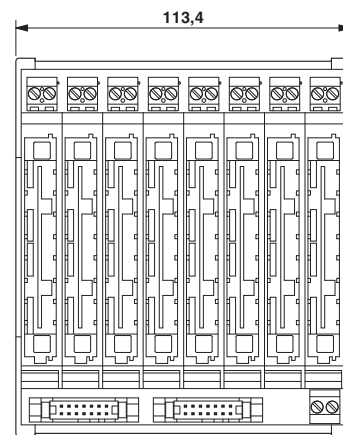

## Approvals

### Approvals

Approvals

EAC

Ex Approvals

ATEX

### Approval details

## Basic terminal block - UM122-2FLK14/EX-MB/8/IN/S7 - 2865146

### Approvals

EAC



RU C-  
DE.A\*30.B.01742

Phoenix Contact 2018 © - all rights reserved  
<http://www.phoenixcontact.com>

PHOENIX CONTACT GmbH & Co. KG  
Flachsmarktstr. 8  
32825 Blomberg  
Germany  
Tel. +49 5235 300  
Fax +49 5235 3 41200  
<http://www.phoenixcontact.com>

## X-ON Electronics

Largest Supplier of Electrical and Electronic Components

*Click to view similar products for [Pluggable Terminal Blocks](#) category:*

*Click to view products by [Phoenix Contact](#) manufacturer:*

Other Similar products are found below :

[57.510.0053](#) [MC 1.5/ 6-ST-3.5 GY AU](#) [734-104](#) [734-302](#) [8-141-P](#) [8426620000](#) [860505](#) [860810](#) [GBPACX-12](#) [93.731.4953.0](#) [PV05-5,08-K](#)  
[PVP02-5,00](#) [PVP03-3,50](#) [PVP04-3,50](#) [PVS02-5,00](#) [1-1986160-3](#) [1377680000](#) [1531000000](#) [1546228-5](#) [ELFH16150](#) [ELFP03110](#)  
[ELFP10210](#) [ELFT06250](#) [ELVP03100](#) [1700101](#) [1700410](#) [1700425](#) [1702246](#) [1705229](#) [1710175](#) [1714537](#) [1717806](#) [1719600](#) [1728941](#)  
[1734692](#) [1734795](#) [1736036](#) [1740194](#) [1740291](#) [1740628](#) [1740990](#) [1746952](#) [1750207](#) [1752441](#) [1752865](#) [1754115](#) [1754144](#) [1756913](#)  
[1760051](#) [1760336](#)