

# Power supply unit - QUINT-PS/1AC/48DC/10 - 2866682

Please be informed that the data shown in this PDF Document is generated from our Online Catalog. Please find the complete data in the user's documentation. Our General Terms of Use for Downloads are valid (<http://phoenixcontact.com/download>)



Primary-switched QUINT POWER power supply for DIN rail mounting with SFB (Selective Fuse Breaking) Technology, input: 1-phase, output: 48 V DC/10 A

## Product Description

QUINT POWER power supplies with maximum functionality

QUINT POWER circuit breakers magnetically and therefore quickly trip at six times the nominal current, for selective and therefore cost-effective system protection. The high level of system availability is additionally ensured, thanks to preventive function monitoring, as it reports critical operating states before errors occur.

Reliable starting of heavy loads takes place via the static power reserve POWER BOOST. Thanks to the adjustable voltage, all ranges between 5 V DC ... 56 V DC are covered.

## Your advantages

- Quick tripping of standard circuit breakers
- Reliable starting of difficult loads
- Preventive function monitoring



## Key Commercial Data

Packing unit	1 pc
GTIN	 4 046356 307680
GTIN	4046356307680

## Technical data

### Dimensions

Width	90 mm
Height	130 mm
Depth	125 mm
Width with alternative assembly	122 mm
Height with alternative assembly	130 mm
Depth with alternative assembly	93 mm
Installation distance right/left	5 mm / 5 mm
Installation distance top/bottom	50 mm / 50 mm

# Power supply unit - QUINT-PS/1AC/48DC/10 - 2866682

## Technical data

### Ambient conditions

Degree of protection	IP20
Ambient temperature (operation)	-25 °C ... 70 °C (> 60 °C Derating: 2.5 %/K)
Ambient temperature (start-up type tested)	-40 °C
Ambient temperature (storage/transport)	-40 °C ... 85 °C
Max. permissible relative humidity (operation)	≤ 95 % (at 25 °C, non-condensing)
Climatic class	3K3 (in acc. with EN 60721)
Degree of pollution	2
Installation height	6000 m

### Input data

Nominal input voltage range	100 V AC ... 240 V AC
Input voltage range	85 V AC ... 264 V AC
	90 V DC ... 350 V DC (UL 508: ≤ 250 V DC)
Dielectric strength maximum	300 V AC
AC frequency range	45 Hz ... 65 Hz
Frequency range DC	0 Hz
Discharge current to PE	< 3.5 mA
Current consumption	5.1 A (120 V AC)
	2.3 A (230 V AC)
	4.8 A (110 V DC)
	2.4 A (220 V DC)
Nominal power consumption	572 VA
Inrush current	< 20 A (typical)
Mains buffering time	> 20 ms (120 V AC)
	> 20 ms (230 V AC)
Input fuse	12 A (slow-blow, internal)
Recommended breaker for input protection	10 A ... 16 A (AC: Characteristics B, C, D, K)
Type of protection	Transient surge protection
Protective circuit/component	Varistor

### Output data

Nominal output voltage	48 V DC ±1 %
Setting range of the output voltage ( $U_{Set}$ )	30 V DC ... 56 V DC (> 48 V DC, constant capacity restricted)
Nominal output current ( $I_N$ )	10 A (-25 °C ... 60 °C, $U_{OUT} = 48$ V DC)
POWER BOOST ( $I_{Boost}$ )	13 A (-25 °C ... 40 °C permanent, $U_{OUT} = 48$ V DC)
Selective Fuse Breaking ( $I_{SFB}$ )	60 A (12 ms)
Derating	60 °C ... 70 °C (2.5%/K)
Connection in parallel	Yes, for redundancy and increased capacity
Connection in series	yes
Feedback voltage resistance	max. 60 V DC
Protection against overvoltage at the output (OVP)	< 60 V DC

# Power supply unit - QUINT-PS/1AC/48DC/10 - 2866682

## Technical data

### Output data

Active current limitation	$I_{BOOST} = 13 \text{ A}$ (for short-circuit), approximately
Control deviation	< 1 % (change in load, static 10 % ... 90 %)
	< 2 % (change in load, dynamic 10 % ... 90 %)
	< 0.1 % (change in input voltage $\pm 10$ %)
Residual ripple	< 80 mV <sub>PP</sub> (with nominal values)
Output power	480 W
Typical response time	< 1 s
Maximum power dissipation in no-load condition	16 W
Power loss nominal load max.	41 W

### General

Net weight	1.7 kg
Efficiency	> 93 % (for 230 V AC and nominal values)
MTBF (IEC 61709, SN 29500)	> 900000 h (25 °C)
	> 630000 h (40 °C)
Insulation voltage input/output	4 kV AC (type test)
	2 kV AC (routine test)
Insulation voltage input / PE	3.5 kV AC (type test)
	2 kV AC (routine test)
Insulation voltage output / PE	500 V DC (routine test)
Degree of protection	IP20
Protection class	I
Mounting position	horizontal DIN rail NS 35, EN 60715
Assembly instructions	alignable: $P_N \geq 50\%$ , 5 mm horizontally, 15 mm next to active components, 50 mm vertically alignable: $P_N < 50\%$ , 0 mm horizontally, 40 mm vertically top, 20 mm vertically bottom

### Connection data, input

Connection method	Screw connection
Conductor cross section solid min.	0.2 mm <sup>2</sup>
Conductor cross section solid max.	6 mm <sup>2</sup>
Conductor cross section flexible min.	0.2 mm <sup>2</sup>
Conductor cross section flexible max.	4 mm <sup>2</sup>
Conductor cross section AWG min.	18
Conductor cross section AWG max.	10
Stripping length	7 mm
Screw thread	M3

### Connection data, output

Connection method	Screw connection
Conductor cross section solid min.	0.2 mm <sup>2</sup>
Conductor cross section solid max.	6 mm <sup>2</sup>

# Power supply unit - QUINT-PS/1AC/48DC/10 - 2866682

## Technical data

### Connection data, output

Conductor cross section flexible min.	0.2 mm <sup>2</sup>
Conductor cross section flexible max.	4 mm <sup>2</sup>
Conductor cross section AWG min.	12
Conductor cross section AWG max.	10
Stripping length	7 mm
Screw thread	M3

### Connection data for signaling

Connection method	Screw connection
Conductor cross section solid min.	0.2 mm <sup>2</sup>
Conductor cross section solid max.	6 mm <sup>2</sup>
Conductor cross section flexible min.	0.2 mm <sup>2</sup>
Conductor cross section flexible max.	4 mm <sup>2</sup>
Conductor cross section AWG min.	18
Conductor cross section AWG max.	10
Screw thread	M3

### Standards and Regulations

Electromagnetic compatibility	Conformance with EMC Directive 2014/30/EU
Noise emission	EN 55011 (EN 55022)
Noise immunity	EN 61000-6-2
Connection in acc. with standard	CSA
Standards/regulations	EN 61000-4-2
Contact discharge	4 kV (Test Level 2)
Standards/regulations	EN 61000-4-3
Frequency range	80 MHz ... 1 GHz
Test field strength	10 V/m (Test Level 3)
Frequency range	1.4 GHz ... 2 GHz
Test field strength	3 V/m (Test Level 2)
Standards/regulations	EN 61000-4-4
Comments	Criterion B
Standards/regulations	EN 61000-6-3
	EN 61000-4-6
Frequency range	0.15 MHz ... 80 MHz
Voltage	10 V (Test Level 3)
Low Voltage Directive	Conformance with Low Voltage Directive 2014/35/EC
Standard - Electrical safety	IEC 60950-1/VDE 0805 (SELV)
Standard – Electronic equipment for use in electrical power installations and their assembly into electrical power installations	EN 50178/VDE 0160 (PELV)
Standard – Safety extra-low voltage	IEC 60950-1 (SELV) and EN 60204-1 (PELV)
Standard - Safe isolation	DIN VDE 0100-410

# Power supply unit - QUINT-PS/1AC/48DC/10 - 2866682

## Technical data

### Standards and Regulations

Standard – Protection against shock currents, basic requirements for protective separation in electrical equipment	EN 50178
Standard – Limitation of mains harmonic currents	EN 61000-3-2
Standard - Equipment safety	BG (design tested)
Standard - Approval for medical use	IEC 60601-1, 2 x MOOP
UL approvals	UL Listed UL 508
	UL/C-UL Recognized UL 60950-1
	UL ANSI/ISA-12.12.01 Class I, Division 2, Groups A, B, C, D (Hazardous Location)
Shock	18 ms, 30g, in each space direction (according to IEC 60068-2-27)
Vibration (operation)	< 15 Hz, amplitude ±2.5 mm (according to IEC 60068-2-6)
	15 Hz ... 150 Hz, 2.3g, 90 min.
Approval - requirement of the semiconductor industry with regard to mains voltage dips	Semi F47-0706
Certificate	CB Scheme
Rail applications	EN 50121-4
Overvoltage category (EN 62477-1)	III

### Environmental Product Compliance

REACH SVHC	Lead 7439-92-1
China RoHS	Environmentally Friendly Use Period = 25;
	For details about hazardous substances go to tab “Downloads”, Category “Manufacturer's declaration”

## Drawings

Block diagram

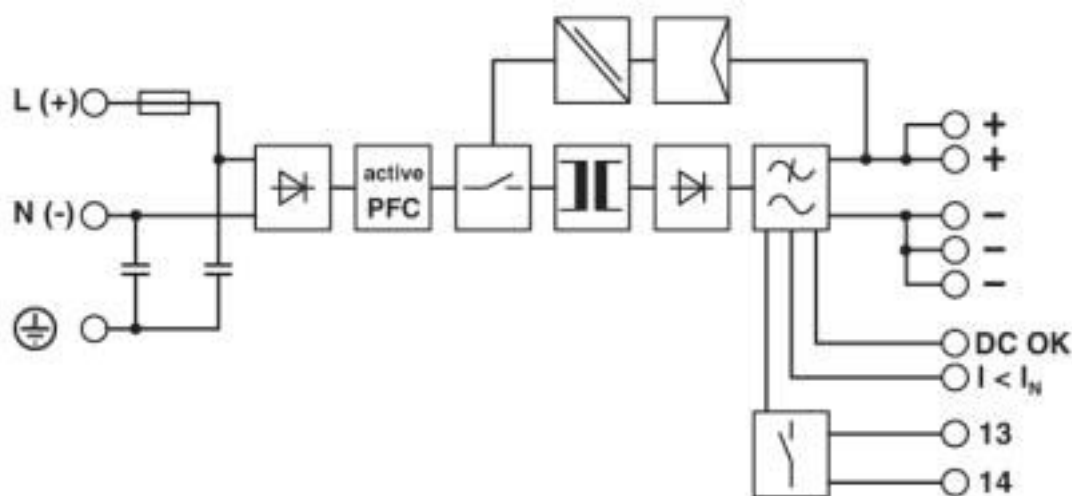

# Power supply unit - QUINT-PS/1AC/48DC/10 - 2866682

## Classifications

### eCl@ss

eCl@ss 10.0.1	27040701
eCl@ss 4.0	27040700
eCl@ss 4.1	27040700
eCl@ss 5.0	27242200
eCl@ss 5.1	27242200
eCl@ss 6.0	27049000
eCl@ss 7.0	27049002
eCl@ss 8.0	27049002
eCl@ss 9.0	27040701

### ETIM

ETIM 2.0	EC001039
ETIM 3.0	EC001039
ETIM 4.0	EC002540
ETIM 5.0	EC002540
ETIM 6.0	EC002540
ETIM 7.0	EC002540

### UNSPSC

UNSPSC 6.01	30211502
UNSPSC 7.0901	39121004
UNSPSC 11	39121004
UNSPSC 12.01	39121004
UNSPSC 13.2	39121004
UNSPSC 18.0	39121004
UNSPSC 19.0	39121004
UNSPSC 20.0	39121004
UNSPSC 21.0	39121004

## Approvals

### Approvals

#### Approvals

DNV GL / CSA / UL Listed / UL Recognized / cUL Recognized / IECCE CB Scheme / cUL Listed / SEMI F47 / EAC / EAC / cULus Recognized / cULus Listed

#### Ex Approvals

UL Listed / cUL Listed / cULus Listed

# Power supply unit - QUINT-PS/1AC/48DC/10 - 2866682

## Approvals

### Approval details

DNV GL		<a href="https://approvalfinder.dnvgl.com/">https://approvalfinder.dnvgl.com/</a>	TAE000014W
CSA		<a href="http://www.csagroup.org/services-industries/product-listing/">http://www.csagroup.org/services-industries/product-listing/</a>	2162676
UL Listed		<a href="http://database.ul.com/cgi-bin/XYV/template/LISEXT/1FRAME/index.htm">http://database.ul.com/cgi-bin/XYV/template/LISEXT/1FRAME/index.htm</a>	FILE E 123528
UL Recognized		<a href="http://database.ul.com/cgi-bin/XYV/template/LISEXT/1FRAME/index.htm">http://database.ul.com/cgi-bin/XYV/template/LISEXT/1FRAME/index.htm</a>	FILE E 211944
cUL Recognized		<a href="http://database.ul.com/cgi-bin/XYV/template/LISEXT/1FRAME/index.htm">http://database.ul.com/cgi-bin/XYV/template/LISEXT/1FRAME/index.htm</a>	FILE E 211944
IECEE CB Scheme		<a href="http://www.iecee.org/">http://www.iecee.org/</a>	SI-2283 A1
cUL Listed		<a href="http://database.ul.com/cgi-bin/XYV/template/LISEXT/1FRAME/index.htm">http://database.ul.com/cgi-bin/XYV/template/LISEXT/1FRAME/index.htm</a>	FILE E 123528
SEMI F47			SEMI F47
EAC			EAC-Zulassung
EAC			RU*DE*08.B.01873/19
cULus Recognized			

# Power supply unit - QUINT-PS/1AC/48DC/10 - 2866682

## Approvals

cULus Listed



## Accessories

### Accessories

#### Assembly adapter

Assembly adapters - UWA 182/52 - 2938235



Universal wall adapter for securely mounting the device in the event of strong vibrations. The device is screwed directly onto the mounting surface. The universal wall adapter is attached on the top/bottom.

## Device protection

Type 3 surge protection device - PLT-SEC-T3-230-FM-UT - 2907919



Type 2/3 surge protection, consisting of protective plug and base element with screw connection. For single-phase power supply network with integrated status indicator and remote signaling. Nominal voltage 230 V AC/DC.

Type 3 surge protection device - PLT-SEC-T3-60-FM-UT - 2907917



Type 3 surge protection, consisting of protective plug and base element, with integrated status indicator and remote signaling for single-phase power supply networks. Nominal voltage 60 V AC/DC.

## Mounting rail adapter

DIN rail adapter - UTA 107 - 2853983

Universal DIN rail adapter, for screwing on switchgear



## Redundancy module



## Power supply unit - QUINT-PS/1AC/48DC/10 - 2866682

### Accessories

Diode - QUINT-DIODE/48DC/2X20/1X40 - 2320160



DIN rail diode module 48 V DC/2x20 A or 1x40 A. Uniform redundancy up to the consumer.

---

Redundancy module - TRIO-DIODE/48DC/2X10/1X20 - 2866527



Redundancy module with function monitoring, 48 V DC, 2x 10 A, 1x 20 A

---

### Thermomagnetic device circuit breakers

Thermomagnetic device circuit breaker - CB TM1 1A SFB P - 2800836



Thermomagnetic device circuit breaker, 1-pos., tripping characteristic SFB, 1 PDT contact, plug for base element.

---

Thermomagnetic device circuit breaker - CB TM1 2A SFB P - 2800837



Thermomagnetic device circuit breaker, 1-pos., tripping characteristic SFB, 1 PDT contact, plug for base element.

---

Thermomagnetic device circuit breaker - CB TM1 3A SFB P - 2800838



Thermomagnetic device circuit breaker, 1-pos., tripping characteristic SFB, 1 PDT contact, plug for base element.

---

## Power supply unit - QUINT-PS/1AC/48DC/10 - 2866682

### Accessories

Thermomagnetic device circuit breaker - CB TM1 4A SFB P - 2800839



Thermomagnetic device circuit breaker, 1-pos., tripping characteristic SFB, 1 PDT contact, plug for base element.

---

Thermomagnetic device circuit breaker - CB TM1 5A SFB P - 2800840



Thermomagnetic device circuit breaker, 1-pos., tripping characteristic SFB, 1 PDT contact, plug for base element.

---

---

Phoenix Contact 2020 © - all rights reserved  
<http://www.phoenixcontact.com>

PHOENIX CONTACT GmbH & Co. KG  
Flachsmarktstr. 8  
32825 Blomberg  
Germany  
Tel. +49 5235 300  
Fax +49 5235 3 41200  
<http://www.phoenixcontact.com>

## X-ON Electronics

Largest Supplier of Electrical and Electronic Components

*Click to view similar products for [DIN Rail Power Supplies](#) category:*

*Click to view products by [Phoenix Contact](#) manufacturer:*

Other Similar products are found below :

[PS-S6024](#) [DVP01PU-S](#) [DVP06AD-S](#) [DVP06XA-S](#) [DVDPNET-SL](#) [DVPDT01-S](#) [DVPPS01](#) [PS-6012](#) [PS9Z-5R1G](#) [PS-C24024](#)  
[DVP08ST11N](#) [DVPACAB530](#) [DVPCOPM-SL](#) [DVPEN01-SL](#) [DVPPF01-S](#) [ADNB008-48-1PM-C](#) [ADNB017-24-1PM-C](#) [ADNB040-24-1PM-C](#) [ADNB034-12-1PM-C](#) [SS14011524](#) [S8TS-06024-E1](#) [PS-UPS40](#) [PSC-6024](#) [PSD-A60W12](#) [96PS-A120WDIN](#) [PSD-A60W48](#) [PSD-A40W12](#) [PSD-A40W24](#) [SMP21-L20-DC24V-5A](#) [PSD-A40W48](#) [S8T-DCBU-02](#) [PS-S4024](#) [NTPS-24-1.3](#) [PST-96024](#) [S82YVSC4P](#) [PS-S4005](#) [PS-10024](#) [PS-S10024](#) [PS-C12024](#) [PSP-480S24](#) [PS-C48024](#) [PSC-2024](#) [PSC-4012](#) [PSC-4048](#) [PSC-9615](#) [PSC-15124](#) [PSC-15148](#)  
[PSC-24148](#) [PSC-48148](#) [TRIO-PS-2G/1AC/12DC/5/C2LP](#)