

## Electronic housing - ECS-B-122X169-L-UV1-V - 2230000

Please be informed that the data shown in this PDF Document is generated from our Online Catalog. Please find the complete data in the user's documentation. Our General Terms of Use for Downloads are valid (<http://phoenixcontact.com/download>)

Snap-in locking vented enclosure of the ECS Family. IP66/67/69 rated when mated with associated faceplate. Color: Black (9005), Width: 170 mm, Height: 176 mm, Depth: 64 mm



### Your advantages

- Part of the EnviroCase System
- Suitable for outdoor/indoor applications
- IP66/IP67 rated with faceplate secured to the base
- Wall, panel, or pole mounting options
- Toolless assembly
- Breather vent

### Key Commercial Data

Packing unit	5 pc
Minimum order quantity	5 pc
GTIN	 4 055626 381336
GTIN	4055626381336

### Technical data

#### Item properties

Type	ECS-B-122X169-L-UV1-V
Order No.	2230000
Housing type	outdoor housings
Type	Snap-in locking
Impact strength	IK08
Mounting type	Wall or panel mount. Pole mount with accessory.
Ventilation	integrated pressure compensation membrane
Type of locking	Snap-in locking

#### Measurements

# Electronic housing - ECS-B-122X169-L-UV1-V - 2230000

## Technical data

### Measurements

Width [ w ]	170 mm
Height [ h ]	176 mm
Depth [ d ]	64 mm

### Material specifications

Color (RAL)	black (9005)
Flammability rating according to UL 94	V0
Housing material	PC (polycarbonate)

### Ambient conditions

Ambient temperature (operation)	-40 °C ... 100 °C
---------------------------------	-------------------

### PCB data

PCB thickness	1.57 mm ... 2.36 mm
---------------	---------------------

### Power dissipation, single housing at 20°C

Ambient temperature	20 °C
Reduction factor	1
Mounting position	vertical
Power dissipation	19 W

### Hammer test

Specification	DIN EN 50155 (VDE 0115-200):2008-03
Impact energy	5 J
Number of drop cycles	5

### Vibration test

Frequency	10 - 2000 - 10 Hz
Sweep speed	1 octave/min
Acceleration	150 m/s <sup>2</sup>
Test duration per axis	150 min.
Test directions	X-, Y- and Z-axis

### Shock

Pulse shape	Semi-sinusoidal
Acceleration	50g
Shock duration	11 ms
Number of shocks per direction	3
Test directions	X-, Y- and Z-axis (pos. and neg.)

### Test for assessing the risk of fire (glow wire)

Specification	DIN EN 60695-2-11 (VDE 0471-2-11):2014-11
Temperature	850 °C
Time of exposure	30 s

### Salt mist

# Electronic housing - ECS-B-122X169-L-UV1-V - 2230000

## Technical data

### Salt mist

Test duration	96 h
---------------	------

### Packaging information

Pieces per package	5
Denomination packing units	Pcs.

### Standards and regulations

Flammability rating according to UL 94	V0
--	----

### Environmental Product Compliance

China RoHS	Environmentally friendly use period: unlimited = EFUP-e
	No hazardous substances above threshold values

## Drawings

# Electronic housing - ECS-B-122X169-L-UV1-V - 2230000

Dimensional drawing

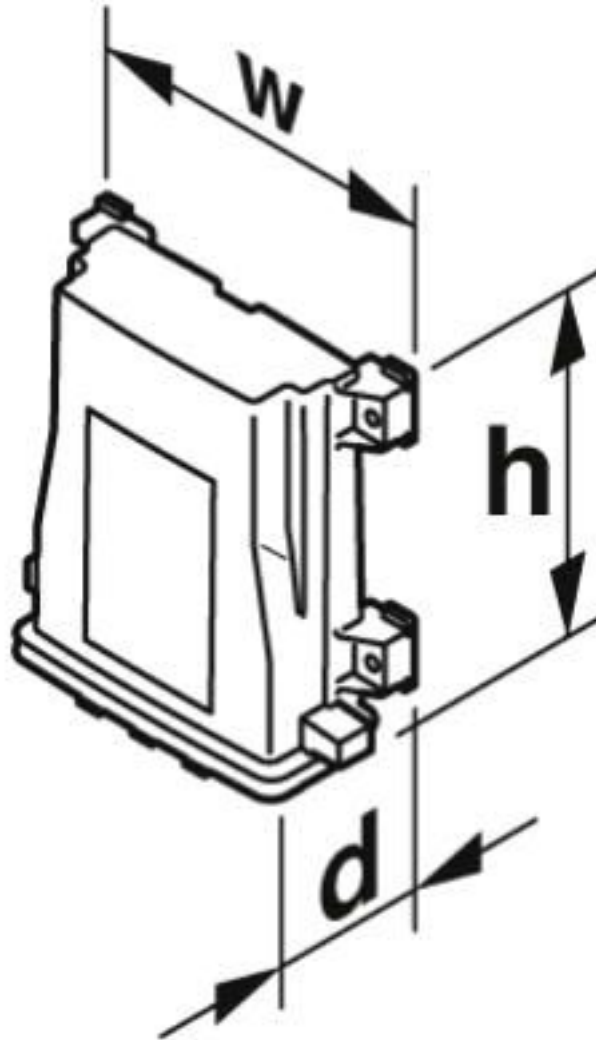

## Classifications

eCl@ss

eCl@ss 10.0.1	27182702
eCl@ss 4.0	27180401
eCl@ss 4.1	27180401
eCl@ss 5.0	27180505
eCl@ss 5.1	27180505
eCl@ss 6.0	27180800
eCl@ss 7.0	27182702
eCl@ss 8.0	27182702
eCl@ss 9.0	27182702

# Electronic housing - ECS-B-122X169-L-UV1-V - 2230000

## Classifications

### ETIM

ETIM 3.0	EC001031
ETIM 4.0	EC001031
ETIM 5.0	EC000058
ETIM 6.0	EC001031
ETIM 7.0	EC001031

### UNSPSC

UNSPSC 6.01	31261501
UNSPSC 7.0901	31261501
UNSPSC 11	31261501
UNSPSC 12.01	31261501
UNSPSC 13.2	31261501
UNSPSC 18.0	31261501
UNSPSC 19.0	31261501
UNSPSC 20.0	31261501
UNSPSC 21.0	31261501

## Accessories

### Accessories

#### Screwdriver tools

Screwdriver - SF-TXH 20X100 - 1200151



Screwdriver, Torx® with bore hole, TX 20 x 100, two-component handle

### Additional products

Front plate - ECS-P-122X169-L-UV1-B - 2230004

Snap-in locking blank faceplate of the ECS Family. IP66/67/69 rated when mated with associated enclosure. Color: Black (9005), Width: 196 mm, Height: 34 mm, Depth: 62 mm



## Electronic housing - ECS-B-122X169-L-UV1-V - 2230000

### Accessories

#### Front plate - ECS-P-122X169-L-UV1-1M12 - 2230005

Snap-in locking one female M12 faceplate of the ECS Family. IP66/67/69 rated when mated with associated enclosure. Color: Black (9005), Width: 196 mm, Height: 34 mm, Depth: 62



#### Front plate - ECS-P-122X169-L-UV1-2M12 - 2230006

Snap-in locking two female M12 faceplate of the ECS Family. IP66/67/69 rated when mated with associated enclosure. Color: Black (9005), Width: 196 mm, Height: 34 mm, Depth: 62 mm



#### Front plate - ECS-P-122X169-L-UV1-CG - 2230007

Snap-in locking cable gland faceplate of the ECS Family. IP66/67/69 rated when mated with associated enclosure. Color: Black (9005), Width: 196 mm, Height: 34 mm, Depth: 62 mm



#### Safety clip - ECS-BL - 2230012

Clip to prevent PCB from dropping from base when faceplate is removed.



#### Mounting brackets - ECS-PM - 2230013

Mounting set for mast mounting



Phoenix Contact 2020 © - all rights reserved  
<http://www.phoenixcontact.com>

PHOENIX CONTACT GmbH & Co. KG  
Flachmarktstr. 8  
32825 Blomberg  
Germany  
Tel. +49 5235 300  
Fax +49 5235 3 41200  
<http://www.phoenixcontact.com>

## X-ON Electronics

Largest Supplier of Electrical and Electronic Components

*Click to view similar products for [Phoenix Contact](#) manufacturer:*

Other Similar products are found below :

[1203259](#) [1893300](#) [1212619](#) [1927221](#) [1936102](#) [1730573](#) [3240366](#) [3240367](#) [1014246](#) [1014236](#) [1014240](#) [1014290](#) [1014293](#) [1806193](#)  
[1823655](#) [1912825](#) [1842254](#) [1768260](#) [1716373](#) [1648030](#) [1579051](#) [1014235](#) [1014239](#) [1014229](#) [1212378](#) [2800744](#) [3006564](#) [2800741](#)  
[5146480](#) [1623633](#) [1507793](#) [3025587](#) [3069708](#) [1431461](#) [1586976](#) [0311647](#) [1460160](#) [1771338](#) [3048387](#) [2814605](#) [0309086](#) [1513716](#)  
[3035684](#) [5451417](#) [0202219](#) [1647747](#) [1730667](#) [1709267](#) [5449018](#) [0311634](#)