



LM321

Low Power Single Operational Amplifier

Description

LM321 is a low power, wide power range performance operational amplifier; The static current is only 430 μA per amplifier (5V) with high unit gain frequency and A voltage swing rate of 0.4V/ μs . Input common model circuit includes ground, so the device can operate in single - and dual-power applications. It can also comfortably drive large capacity loads.

Features

- Low quiescent current
- Low input bias current
- Wide range of supply voltage
- High capacity load stability

Application

- Communication infrastructure
- Battery charger
- Power supply

Pin arrangement diagram

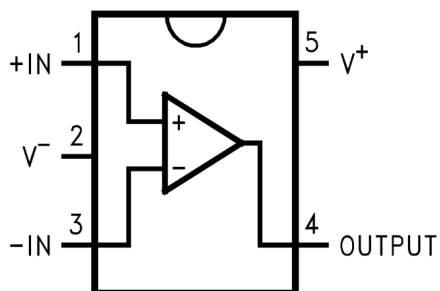

SOT-23-5

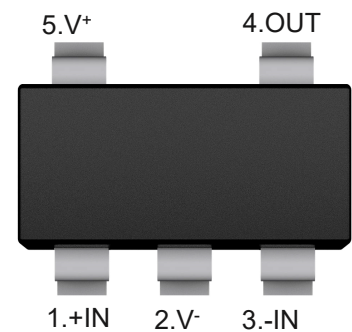

Absolute Maximum Ratings (T_A=25°C)

Parameter	Symbol	Value	Units
Supply Voltage	V _{CC}	24 or ±12	V
Differential Input Voltage	V _{ID}	24	V
Input Voltage	V _{IN}	-0.3~V _{CC}	V
Power Dissipation	P _D	530	mW
Output Short Circuit to GND V _o ≤15V, T _a =25°C	I _o	Continuous	
Input Current V _{IN} <-0.3V	I _{IN}	50	mA
Junction Temperature	T _J	150	°C
Operating Temperature Range	T _{OPR}	0 to 70	°C
Storage Temperature Range	T _{STG}	-65 to 150	°C

Electrical Characteristics

 At V_{CC}=5V, unless otherwise noted.

Parameter	Symbol	Conditions	Min.	Typ.	Max.	Units	
Input Offset Voltage	V _{OS}	T _a =25°C	--	±2	±5	mV	
Input offset current	I _{OS}	T _a =25°C, I _{IN} (+) - I _{IN} (-), V _{CM} =0V	--	±3	±50	nA	
Input bias current	I _B	T _a =25°C, I _{IN} (+) or I _{IN} (-), V _{CM} =0V	--	±45	±250	nA	
Common-mode input voltage range	V _{CM}	T _a =25°C, V ⁺ =24V	0	--	V _{CC} -1.5	V	
Supply current	I _S	V _{CC} =24V, R _L =∞	--	0.7	2	mA	
		V _{CC} =5V, R _L =∞	--	0.5	1.2		
Common Mode Rejection	CMRR	V _{CM} = 0~V _{CC} -1.5V, T _a =25°C, DC	65	90	--	dB	
Power Supply Rejection	PSRR	V _{CC} = 5V~24V, T _a =25°C, DC	65	100	--	dB	
Large signal voltage gain	A _V	V _{CC} = 15V, T _a =25°C, R _L ≥ 2kΩ (for V _o =1~11V)	25	100	--	V/mV	
Output voltage swing	V _O	V _{OH}	V _{CC} = 24V, R _L = 2 kΩ	22	--	--	V
			V _{CC} = 24V, R _L =10 kΩ	22	--	--	V
		V _{OL}	V _{CC} = 5V, R _L =10 kΩ	--	5	20	mV
Output Current Sourcing	I _{SOURCE}	V _{IN} (+) = 1V, V _{IN} (-) = 0V, V _{CC} =15V, V _O =2V, T _a =25°C	20	40	--	mA	
Output Current Sinking	I _{SINK}	V _{IN} (+) = 0V, V _{IN} (-) = 1V, V _{CC} =15V, V _O =2V, T _a =25°C	10	15	--	mA	
		V _{IN} (+) = 0V, V _{IN} (-) = 1V, V _{CC} =15V, V _O =200mV, T _a =25°C	12	50	--	μA	
Output Short Circuit to Ground	I _o	V _{CC} =15V, T _a =25°C	--	40	60	mA	



Typical Applications

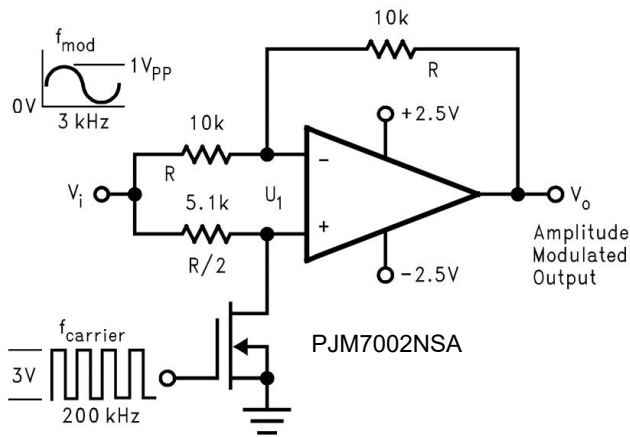

Amplitude modulator circuit

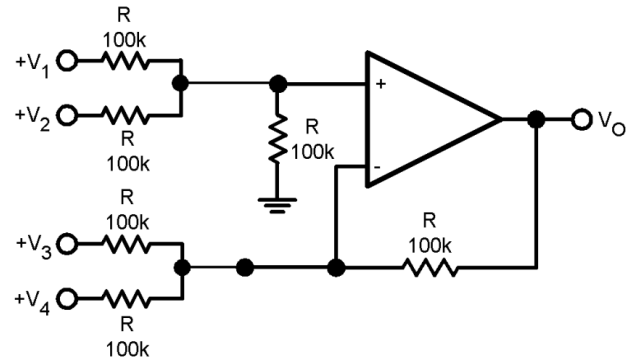

Note: $V_o = V_1 + V_2 - V_3 - V_4$, $(V_1 + V_2) \geq (V_3 + V_4)$ for $V_o \geq 0V_{DC}$

DC adder amplifier

($V_{IN's} \geq 0V_{DC}$, $V_o \geq V_{DC}$)

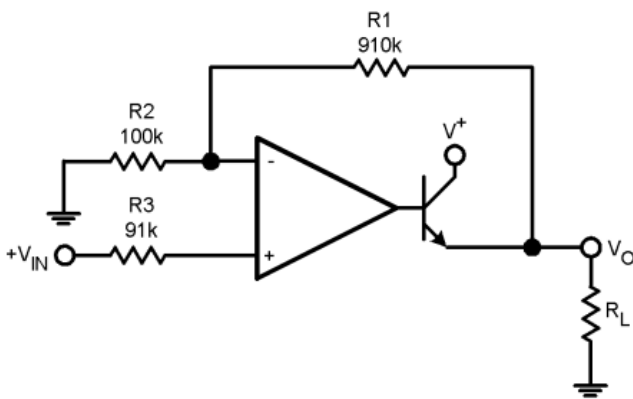

$V_o = 0V_{DC}$ for $V_{IN} = 0V_{DC}$, $A_v = 10$

Power Amplifier

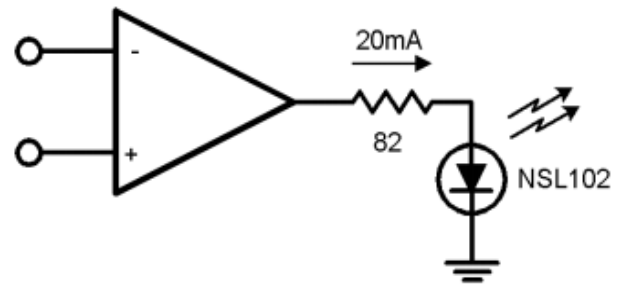

LED Driver

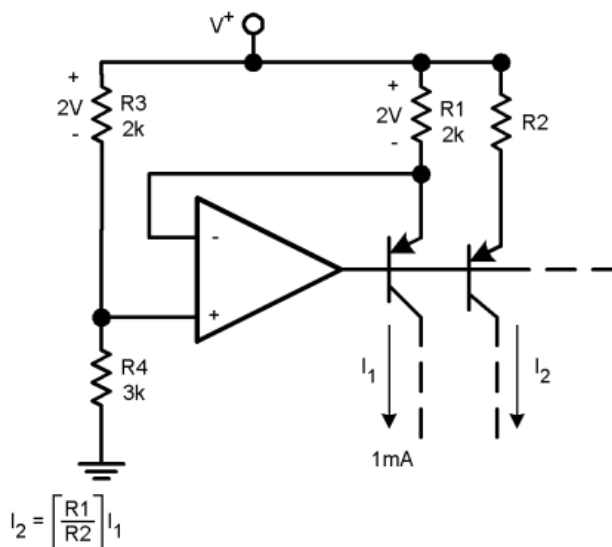

Fixed current source

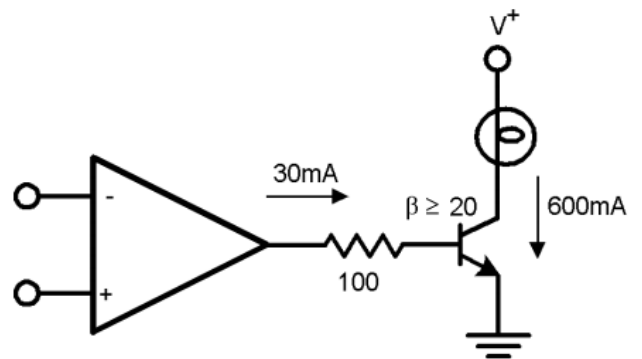

Lamp Driver



Typical characteristic curve

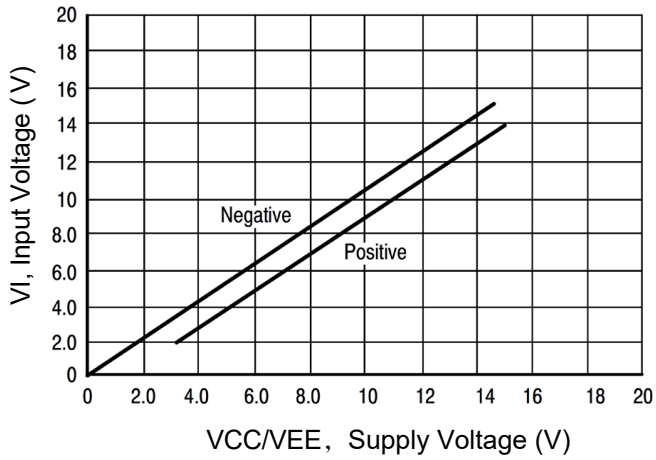

Input Voltage Range

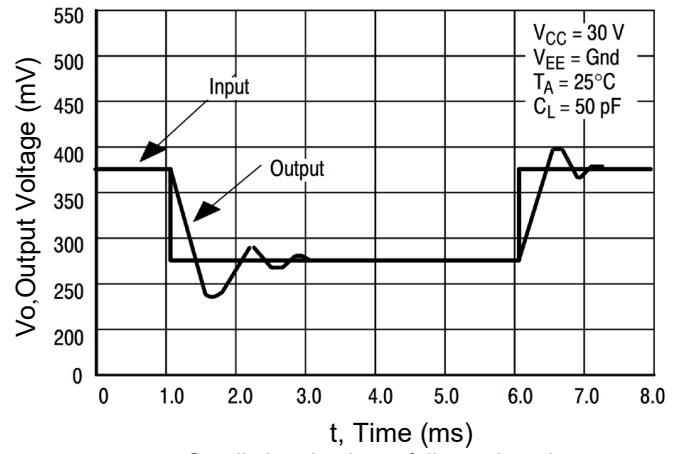

Small signal voltage follower impulse response (same direction)

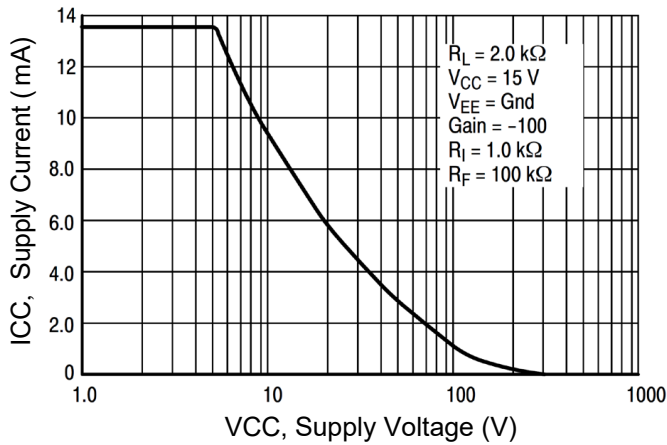

Supply current (static power consumption)

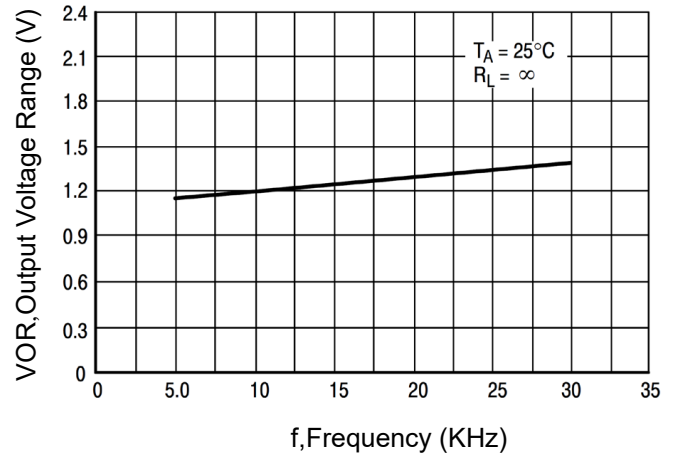

Large signal frequency response

X-ON Electronics

Largest Supplier of Electrical and Electronic Components

Click to view similar products for [Operational Amplifiers - Op Amps](#) category:

Click to view products by [Pingjingsemi](#) manufacturer:

Other Similar products are found below :

[OPA2991IDSGR](#) [OPA607IDCKT](#) [007614D](#) [633773R](#) [635798C](#) [635801A](#) [702115D](#) [709228FB](#) [741528D](#) [NCV33072ADR2G](#)
[SC2902DTBR2G](#) [SC2903DR2G](#) [SC2903VDR2G](#) [LM258AYDT](#) [LM358SNG](#) [430227FB](#) [430228DB](#) [460932C](#) [AZV831KTR-G1](#) [409256CB](#)
[430232AB](#) [LM2904DR2GH](#) [LM358YDT](#) [LT1678IS8](#) [042225DB](#) [058184EB](#) [070530X](#) [SC224DR2G](#) [SC239DR2G](#) [SC2902DG](#)
[SCYA5230DR2G](#) [714228XB](#) [714846BB](#) [873836HB](#) [MIC918YC5-TR](#) [TS912BIYDT](#) [NCS2004MUTAG](#) [NCV33202DMR2G](#)
[M38510/13101BPA](#) [NTE925](#) [SC2904DR2G](#) [SC358DR2G](#) [LM358EDR2G](#) [AZV358MTR-G1](#) [AP4310AUMTR-AG1](#) [HA1630D02MMEL-E](#)
[NJM358CG-TE2](#) [HA1630S01LPEL-E](#) [LM324AWPT](#) [HA1630Q06TELL-E](#)